

www.wackergroup.com

0163091en	003
1007	

Walk-Behind Trowels

CT 36 CT 48



REPAIR MANUAL

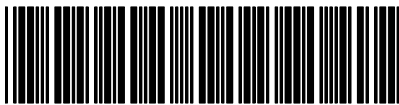

0 1 6 3 0 9 1 E N

This manual covers machines with Item Number:

**0009438, 0009439, 0009442, 0009443, 0009444, 0009447, 0009449,
0009450, 0009452, 0009453, 0620106**

Operating / Parts Information

You must be familiar with the operation of this machine before you attempt to troubleshoot or make any repairs to it. Basic operating and maintenance procedures are described in the operator's / parts manual supplied with the machine. The operator's / parts manual should be kept with the machine. Use it to order replacement parts when needed. If this manual becomes lost, please contact Wacker Corporation to order a replacement.

Damage caused by misuse or neglect of the unit should be brought to the attention of the operator, to prevent similar occurrences from happening in the future.

This manual provides information and procedures to safely repair and maintain the above Wacker model(s). For your own safety and protection from injury, carefully read, understand, and observe all instructions described in this manual. THE INFORMATION CONTAINED IN THIS MANUAL IS BASED ON MACHINES MANUFACTURED UP TO THE TIME OF PUBLICATION. WACKER CORPORATION RESERVES THE RIGHT TO CHANGE ANY PORTION OF THIS INFORMATION WITHOUT NOTICE.

CALIFORNIA

Proposition 65 Warning:



Engine exhaust, some of its constituents, and certain vehicle components, contain or emit chemicals known to the State of California to cause cancer and birth defects or other reproductive harm.

This manual provides information and procedures to safely operate and maintain this Wacker model. For your own safety and protection from injury, carefully read, understand and observe the safety instructions described in this manual.

Keep this manual or a copy of it with the machine. If you lose this manual or need an additional copy, please contact Wacker Corporation. This machine is built with user safety in mind; however, it can present hazards if improperly operated and serviced. Follow operating instructions carefully! If you have questions about operating or servicing this equipment, please contact Wacker Corporation.

The information contained in this manual was based on machines in production at the time of publication. Wacker Corporation reserves the right to change any portion of this information without notice.

All rights, especially copying and distribution rights, are reserved.

Copyright 2007 by Wacker Corporation.

No part of this publication may be reproduced in any form or by any means, electronic or mechanical, including photocopying, without express written permission from Wacker Corporation.

Any type of reproduction or distribution not authorized by Wacker Corporation represents an infringement of valid copyrights and will be prosecuted. We expressly reserve the right to make technical modifications, even without due notice, which aim at improving our machines or their safety standards.

1. Safety Information	8
1.1 Laws Pertaining to Spark Arrestors	8
1.2 Operating Safety	9
1.3 Operator Safety while using Internal Combustion Engines	10
1.4 Service Safety	11
1.5 Label Locations	12
1.6 Safety and Information Labels	13
2. Technical Data	18
2.1 Dimensions and Weight	18
2.2 Engine	20
2.3 Trowel	24
2.4 Sound and Vibration Data	25
3. Operation	26
3.1 Application	26
3.2 New Machine Set-up	26
3.3 Recommended Fuel	26
3.4 Installing Blades	27
3.5 Installing and Adjusting Handles	28
3.6 Controls	30
3.7 Stop Button	31
3.8 Before Starting	31
3.9 To Start - Honda	32
3.10 To Stop - Honda	33
3.11 To Start - Wacker	34
3.12 To Stop - Wacker	35
3.13 Engine Control Module	36
3.14 Operation	36
3.15 Braking System	38
3.16 Pitch Adjustment	39

4.	Maintenance	40
4.1	Periodic Maintenance Schedule - Honda	40
4.2	Periodic Maintenance Schedule - Wacker	41
4.3	Engine Oil - Honda	42
4.4	Engine Oil - Wacker	43
4.5	Air Cleaner - Honda	44
4.6	Air Cleaner - Wacker	45
4.7	Spark Plug	46
4.8	Cleaning Sediment Cup - Honda	47
4.9	Cleaning Fuel Strainer - Wacker	47
4.10	Adjusting Idle Speed - Honda	48
4.11	Carburetor Adjustment - Honda	49
4.12	Belt Replacement	50
4.13	Trowel Lubrication	51
4.14	Optional Weights	51
4.15	Lifting	52
4.16	Storage	54
4.17	Troubleshooting	55
5.	Guide Handle	56
5.1	Replacing the Throttle Cable	56
5.2	Adjusting the Throttle Lever	58
5.3	Upper Handle/Twist Pitch Control—Exploded View	60
5.4	Upper Handle/Twist Pitch Control—Components	61
5.5	Replacing the Upper Handle	62
5.6	Replacing the Twist Pitch Control Cable	64
5.7	Replacing the Lower Handle	66
5.8	Replacing the Stop Switch	67
6.	Clutch	69
6.1	Replacing the Drive Belt	69
6.2	Drive Belt—Standard Clutch	70
6.3	Drive Belt—Variable Speed Clutch	71
6.4	Replacing the Standard Clutch	72
6.5	Standard Clutch—Exploded View	73
6.6	Standard Clutch Overhaul	74
6.7	Replacing the Variable Speed Clutch	76

7.	Spider	78
7.1	Spider Assembly—Exploded View	78
7.2	Spider Assembly—Components	79
7.3	Replacing the Blades	80
7.4	Replacing the Arms	82
7.5	Balancing the Blade Pitch	84
7.6	Removing the Spider	86
7.7	Installing the Spider	88
7.8	Rebuilding the Lift Ring Assembly	90
8.	Drivetrain	92
8.1	Drivetrain—Exploded View	92
8.2	Drivetrain—Components	93
8.3	Engine Removal	94
8.4	Engine Installation	96
8.5	Engine Wiring	98
8.6	Engine Wiring Components	99
8.7	Wiring Diagrams	100
8.8	Engine Wiring Components	101
8.9	Replacing the Gearbox	102
8.10	Gearbox—Exploded View	104
8.11	Gearbox—Components	105
8.12	Gearbox Disassembly	106
8.13	Gearbox Assembly	110

1. Safety Information

This manual contains DANGER, WARNING, CAUTION, NOTICE and NOTE callouts which must be followed to reduce the possibility of personal injury, damage to the equipment, or improper service.



This is the safety alert symbol. It is used to alert you to potential personal injury hazards. Obey all safety messages that follow this symbol to avoid possible injury or death.



DANGER

DANGER indicates a hazardous situation which, if not avoided, will result in death or serious injury.



WARNING

WARNING indicates a hazardous situation which, if not avoided, could result in death or serious injury.



CAUTION

CAUTION indicates a hazardous situation which, if not avoided, could result in minor or moderate injury.

NOTICE: Used without the safety alert symbol, **NOTICE** indicates a hazardous situation which, if not avoided, could result in property damage.

Note: *Contains additional information important to a procedure.*

1.1 Laws Pertaining to Spark Arrestors

Notice: State Health Safety Codes and Public Resources Codes specify that in certain locations spark arresters be used on internal combustion engines that use hydrocarbon fuels. A spark arrester is a device designed to prevent accidental discharge of sparks or flames from the engine exhaust. Spark arresters are qualified and rated by the United States Forest Service for this purpose.

In order to comply with local laws regarding spark arresters, consult the engine distributor or the local Health and Safety Administrator.

1.2 Operating Safety



Familiarity and proper training are required for the safe operation of machine. Machines operated improperly or by untrained personnel can be dangerous. Read the operating instructions contained in both this manual and the engine manual and familiarize yourself with the location and proper use of all controls. Inexperienced operators should receive instruction from someone familiar with the machine before being allowed to operate it.

- 1.2.1 NEVER allow anyone to operate this equipment without proper training. People operating this equipment must be familiar with the risks and hazards associated with it.
- 1.2.2 NEVER touch the engine or muffler while the engine is on or immediately after it has been turned off. These areas get hot and may cause burns.
- 1.2.3 NEVER use accessories or attachments that are not recommended by Wacker. Damage to equipment and injury to the user may result.
- 1.2.4 NEVER leave machine running unattended.
- 1.2.5 NEVER operate the machine with the beltguard missing. Exposed drive belt and pulleys create potentially dangerous hazards that can cause serious injuries.
- 1.2.6 NEVER operate this machine in applications for which it is not intended.
- 1.2.7 NEVER use the trowel around pop-ups in the concrete that are lower than the lowest ring on the ring guard.
- 1.2.8 NEVER lift the machine solely by the handle. The component may fail, causing the machine to fall, possibly injuring bystanders.
- 1.2.9 ALWAYS wear protective clothing appropriate to the job site when operating equipment.
- 1.2.10 ALWAYS wear hearing and eye protection when operating this machine.
- 1.2.11 ALWAYS remain aware of moving parts and keep hands, feet, and loose clothing away from the moving parts of the machine.
- 1.2.12 ALWAYS read, understand, and follow procedures in the Operator's Manual before attempting to operate the equipment.
- 1.2.13 ALWAYS store the equipment properly when it is not being used. Equipment should be stored in a clean, dry location out of the reach of children.
- 1.2.14 ALWAYS close fuel valve on engines equipped with one when machine is not being operated.

- 1.2.15 ALWAYS operate machine with all safety devices and guards in place and in working order. DO NOT modify or defeat safety devices. DO NOT operate machine if any safety devices or guards are missing or inoperative.
- 1.2.16 ALWAYS be sure operator is familiar with proper safety precautions and operation techniques before using machine.
- 1.2.17 ALWAYS test the function of the engine control module before operating the trowel. DO NOT operate the trowel if the engine control module is not functioning properly.

1.3 Operator Safety while using Internal Combustion Engines



DANGER

Internal combustion engines present special hazards during operation and fueling. Read and follow the warning instructions in the engine owner's manual and the safety guidelines below. Failure to follow the warnings and safety guidelines could result in severe injury or death.

- 1.3.1 DO NOT run the machine indoors or in an enclosed area such as a deep trench unless adequate ventilation, through such items as exhaust fans or hoses, is provided. Exhaust gas from the engine contains poisonous carbon monoxide gas; exposure to carbon monoxide can cause loss of consciousness and may lead to death.
- 1.3.2 DO NOT smoke while operating the machine.
- 1.3.3 DO NOT smoke when refueling the engine.
- 1.3.4 DO NOT refuel a hot or running engine.
- 1.3.5 DO NOT refuel the engine near an open flame.
- 1.3.6 DO NOT spill fuel when refueling the engine.
- 1.3.7 DO NOT run the engine near open flames.
- 1.3.8 ALWAYS refill the fuel tank in a well-ventilated area.
- 1.3.9 ALWAYS replace the fuel tank cap after refueling.

1.4 Service Safety



Poorly maintained machines can become a safety hazard! In order for the machine to operate safely and properly over a long period of time, periodic maintenance and occasional repairs are necessary.



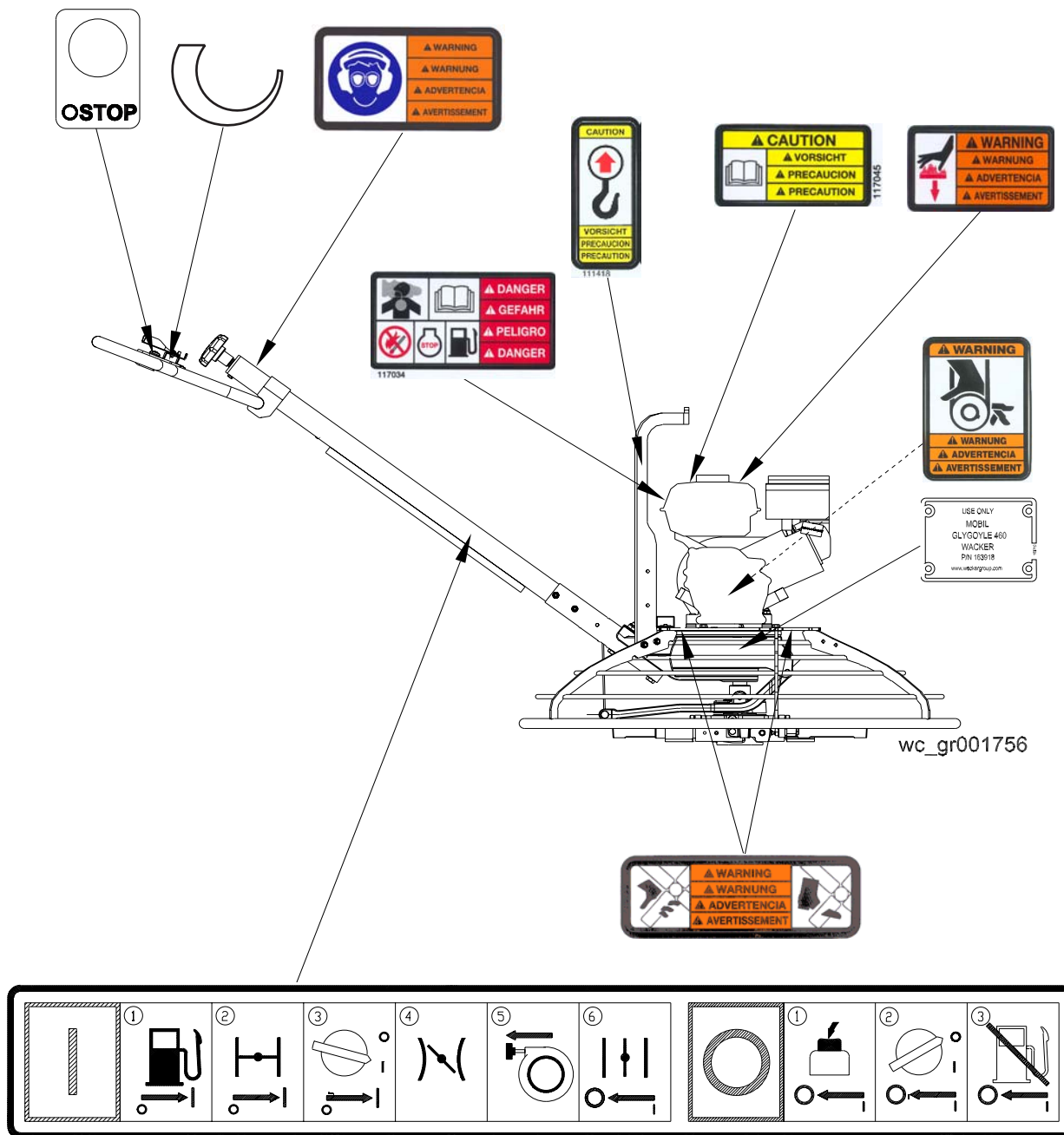

- 1.4.1 DO NOT attempt to clean or service the machine while it is running. Rotating parts can cause severe injury.
- 1.4.2 DO NOT crank a flooded engine with the spark plug removed on gasoline-powered engines. Fuel trapped in the cylinder will squirt out the spark plug opening.
- 1.4.3 DO NOT test for spark on gasoline-powered engines if the engine is flooded or the smell of gasoline is present. A stray spark could ignite the fumes.
- 1.4.4 DO NOT use gasoline or other types of fuels or flammable solvents to clean parts, especially in enclosed areas. Fumes from fuels and solvents can become explosive.
- 1.4.5 DO NOT remove blades while the machine is hanging overhead.
- 1.4.6 ALWAYS support the machine securely before changing blades.
- 1.4.7 ALWAYS keep the area around the muffler free of debris such as leaves, paper, cartons, etc. A hot muffler could ignite the debris and start a fire.
- 1.4.8 ALWAYS replace worn or damaged components with spare parts designed and recommended by Wacker Corporation.
- 1.4.9 ALWAYS disconnect the spark plug on machines equipped with gasoline engines, before servicing, to avoid accidental start-up.
- 1.4.10 ALWAYS keep the machine clean and labels legible. Replace all missing and hard-to-read labels. Labels provide important operating instructions and warn of dangers and hazards.
- 1.4.11 ALWAYS handle blades carefully. The blades can develop sharp edges which can cause serious cuts.





1.5 Label Locations









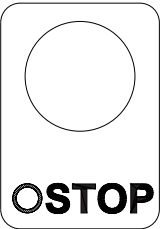

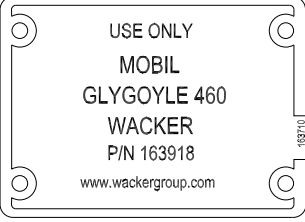
1.6 Safety and Information Labels

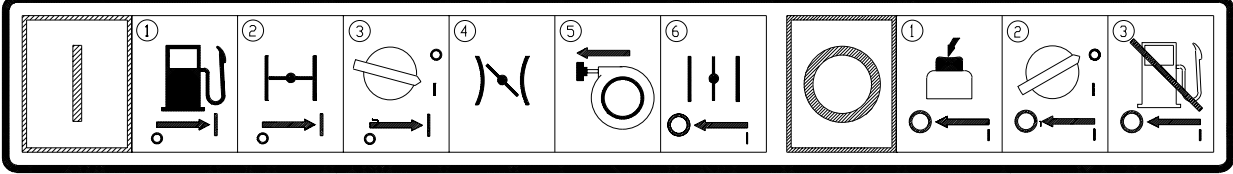

Wacker machines use international pictorial labels where needed. These labels are described below:

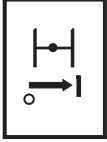
Label	Meaning
 <p>117034</p>	<p>DANGER! Engines emit carbon monoxide; operate only in well-ventilated area. Read the Operator's Manual. No sparks, flames, or burning objects near the machine. Shut off the engine before refueling.</p>
	<p>WARNING! Hot surface!</p>
	<p>WARNING! Hand injury if caught in moving belt. Always replace beltguard.</p>
	<p>WARNING! Always wear hearing and eye protection when operating this machine.</p>
	<p>WARNING! Cutting hazard. Always replace blade guard!</p>

Label	Meaning
	<p>WARNING! Remove pan from trowel before lifting machine overhead. Pans can fall and cause death or serious injury if a person is hit. (Located on top side of float pan.)</p>
	<p>Variable speed throttle</p>
	<p>CAUTION! Read and understand the supplied Operator's Manuals before operating this machine. Failure to do so increases the risk of injury to yourself or others.</p>
	<p>CAUTION! Lifting point.</p>
	<p>Engine stop button: Press to stop engine.</p>

Label	Meaning
	<p>A nameplate listing the model number, item number, revision number, and serial number is attached to each unit. Please record the information found on this plate so it will be available should the nameplate become lost or damaged. When ordering parts or requesting service information, you will always be asked to specify the model number, item number, revision number, and serial number of the unit.</p>
	<p>Use only Glygoyle 460 gear oil in gearbox.</p>
	<p>This machine may be covered by one or more patents.</p>

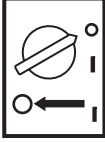
Label	Meaning
	
	<p>Open the fuel flow valve.</p>
	<p>Close the choke.</p>
	<p>Turn engine key switch to "ON" position.</p>
	<p>Place throttle in the IDLE position.</p>
	<p>Pull the rewind starter.</p>
	<p>Open the choke.</p>

Label	Meaning
	<p>Press the stop button.</p>
	<p>Turn engine key switch to "OFF" position.</p>
	<p>Close the fuel flow valve.</p>

2. Technical Data

2.1 Dimensions and Weight

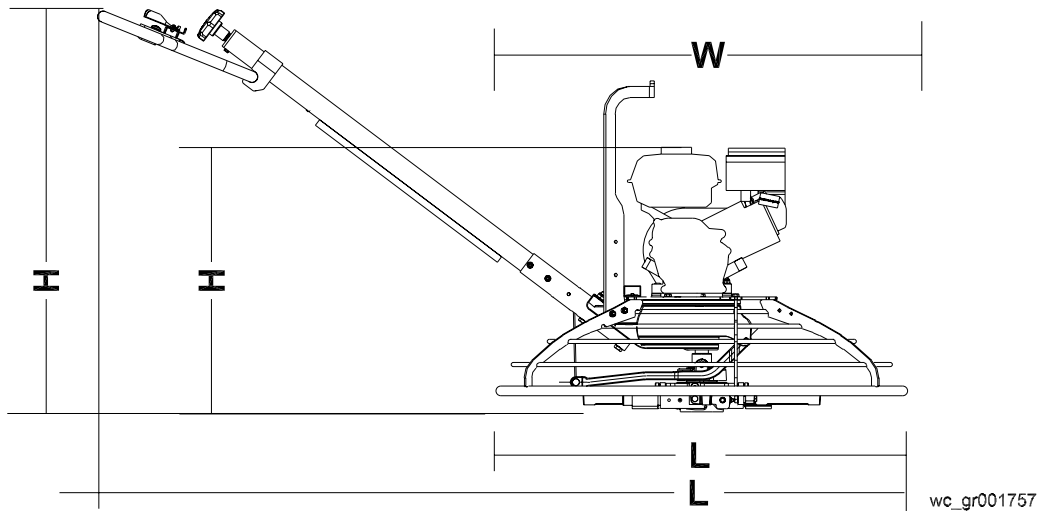

Guide

Description	Ref.	Description	Ref.
Honda engine*	A	Variable Speed	V
Engine Horse Power	4, 5, 6, 8, 9, 11, 13		

*Standard models feature Wacker engine.

Handle Type	Item No.	L mm(in.)	Pitch Type	Weight kg (lbs.)
Solid	0159659	1740 (68.5)	Twist	10 (21)
Folding	0159660	1740 (68.5)	Twist	12 (26.5)
Adjustable/Folding	0164617	1740 (68.5)	Twist	13 (28)
Adjustable	0164535	1740 (68.5)	Twist	11 (24.5)
Adjustable/Folding	0159661	1740 (68.5)	Pro-Shift®	15 (32.5)
Adjustable	0159662	1740 (68.5)	Pro-Shift®	13 (29)

Model	Item No.	without handle	with handle		
		LxWxH mm (in.)	LxWxH mm (in.)	without weight kit kg (lbs.)	with weight kit kg (lbs.)
CT 36-5A	0009438 0620106	915x915x607 (36x36x24)	2005x915x1040 (79x36x41)	85 (183)	91 (201)
CT 36-6	0009443	915x915x607 (36x36x24)	2005x915x1040 (79x36x41)	85 (183)	91 (201)
CT 36-8A	0009439	915x915x686 (36x36x27)	2005x915x1040 (79x36x41)	94 (208)	103 (226)
CT 36-8A-V	0009442	915x915x686 (36x36x27)	2005x915x1040 (79x36x41)	94 (208)	103 (226)
CT 36-9	0009444	915x915x686 (36x36x27)	2005x915x1040 (79x36x41)	90 (199)	98 (217)
CT 36-9-V	0009447	915x915x686 (36x36x27)	2005x915x1040 (79x36x41)	90 (199)	98 (217)
CT 48-8A	0009449	1220x1220x686 (48x48x27)	2160x1220x1040 (85x48x41)	105 (234)	114 (252)
CT 48-9	0009453	1220x1220x686 (48x48x27)	2160x1220x1040 (85x48x41)	105 (234)	114 (252)
CT 48-11A	0009450	1220x1220x712 (48x48x28)	2160x1220x1040 (85x48x41)	113 (250)	122 (268)
CT 48-13A-V	0009452	1220x1220x712 (48x48x28)	2160x1220x1040 (85x48x41)	121 (268)	130 (286)

2.2 Engine

Item No.	CT 36-5A 0009438, 0620106		CT 36-6 0009443	
Engine				
Engine Make	Honda		Wacker	
Engine Model	GX 160 K1 QX2		WM170	
Rated Power	kW (Hp)	4.3 (5.7) @ 3800rpm	4.2 (5.6) @ 3800 rpm	
Spark Plug	NGK BPR 6ES		NGK BR6HS Champion RL86C	
Electrode Gap	mm (in.)	0.7 – 0.8 (0.028 – 0.031)	0.6–0.7 (0.024–0.028)	
Engine Speed - full load	rpm	3800 ± 100		
Engine Speed - idle	rpm	1450 ± 100	1400 ± 100	
Clutch engagement	rpm	1800		
Valve Clearance (cold)	mm (in.)	intake:	0.15 (0.006)	0.07–0.13 (0.0028–0.0051)
		exhaust:	0.20 (0.008)	0.17–0.23 (0.0067–0.0091)
Air Cleaner	type	Dual element		
Engine Lubrication	oil grade	SAE 10W30 SG or SF	SAE 10W30 SE or higher	
Engine Oil Capacity	l (oz.)	0.6 (20)		
Fuel	type	Regular unleaded gasoline		
Fuel Tank Capacity	l (qts.)	3.6 (3.8)		
Fuel Consumption	l (qts.) /hr	1.8 (1.9)	1.52 (1.6)	
Running time	hr.	2	2.4	

Item No.	CT 36-8A 0009439	CT 36-8A-V 0009442	CT36-9 0009444	CT 36-9-V 0009447
Engine				
Engine Make	Honda		Wacker	
Engine Model	GX 240 K1 QA		WM270	
Rated Power	kW (Hp)	6.2 (8.3) @ 3800 rpm		6.5 (8.7) @ 3800 rpm
Spark Plug	NGK BPR 6ES		NGK BR6HS Champion RL86C	
Electrode Gap	mm (in.)	0.7 – 0.8 (0.028 – 0.031)		
Engine Speed - full load	rpm	3800 ± 100		
Engine Speed - idle	rpm	1450 ± 100	1400 ± 100	
Clutch engagement	rpm	1800		
Valve Clearance (cold)	mm (in.)	0.15 (0.006) 0.07–0.13 (0.0028–0.0051)		
intake:		0.17–0.23 (0.0067–0.0091)		
exhaust:		0.20 (0.008)		
Air Cleaner	type	Dual element		
Engine Lubrication	oil grade	SAE 10W30 SG or SF	SAE 10W30 SF, SE, SD, or SC	
Engine Oil Capacity	l (oz.)	1.1 (37)		
Fuel	type	Regular unleaded gasoline		
Fuel Tank Capacity	l (qts.)	6.0 (6.4)		
Fuel Consumption	l (qts.) /hr	2.7 (2.8)	2.5 (2.6)	
Running time	hr.	2.25	2.4	

Item No.	CT 48A-8A 0009449	CT 48-9 0009453
Engine		
Engine Make	Honda	Wacker
Engine Model	GX 240 K1 QA	WM270
Rated Power kW (Hp)	6.2 (8.3) @ 3800 rpm	6.5 (8.7) @ 3800 rpm
Spark Plug	NGK BPR 6ES	NGK BR6HS Champion RL86C
Electrode Gap mm (in.)	0.7 – 0.8 (0.028 – 0.031)	
Engine Speed - full load rpm	3800 ± 100	
Engine Speed - idle rpm	1450 ± 100	1400 ± 100
Clutch engagement rpm	1800	
Valve Clearance (cold) intake: mm (in.)	0.15 (0.006)	0.07–0.13 (0.0028–0.0051)
exhaust:	0.20 (0.008)	0.17–0.23 (0.0067–0.0091)
Air Cleaner type	Dual element	
Engine Lubrication oil grade	SAE 10W30 SG or SF	SAE 10W30 SF, SE, SD, or SC
Engine Oil Capacity l (oz.)	1.1 (37)	
Fuel type	Regular unleaded gasoline	
Fuel Tank Capacity l (qts.)	6.0 (6.4)	
Fuel Consumption l (qts.) /hr	2.7 (2.8)	2.5 (2.6)
Running time hr.	2.25	2.4

Item No.	CT 48-11A 0009450	CT 48-13A-V 0009452
Engine		
Engine Make	Honda	
Engine Model	GX 340 K1 QA	GX 390 U1 QA
Rated Power	kW (Hp)	8.7 (11.6) @ 3800 rpm
		10 (13.4) @ 3800 rpm
Spark Plug	NGK BPR 6ES	
Electrode Gap	mm (in.)	0.7 – 0.8 (0.028 – 0.031)
Engine Speed - full load	rpm	3800 ± 100
Engine Speed - idle	rpm	1450 ± 100
Clutch engagement	rpm	1800
Valve Clearance (cold)		
intake:	mm (in.)	0.15 (0.006)
exhaust:		0.20 (0.008)
Air Cleaner	type	Dual element
Engine Lubrication	oil grade	SAE 10W30 SG or SF
Engine Oil Capacity	l (oz.)	1.1 (37)
Fuel	type	Regular unleaded gasoline
Fuel Tank Capacity	l (qts.)	6.0 (6.4)
Fuel Consumption	l (qts.) /hr	2.7 (2.8)
Running time	hr.	2.25

2.3 Trowel

Model	Item No.	Trowel Diameter* mm (in.)	Number of Blades	Gear Box Lubrication type/ml (oz.)	Speed Range rpm	Pitch Range degrees
Trowel						
CT 36-5A	0009438 0620106	915 (36)	4	Mobil Glygoyle 460 Approx. 620 (21)	60-125	0-30
CT 36-6	0009443				60-125	
CT 36-8A	0009439				60-125	
CT 36-8A-V	0009442				25-200	
CT 36-9	0009444				60-125	
CT 36-9-V	0009447				25-200	
CT 48-8A	0009449	1220 (48)			60-125	
CT 48-9	0009453					
CT 48-11A	0009450					
CT 48-13A-V	0009452				25-200	

*Trowel blades must NOT be interchanged, i.e., do NOT put larger diameter blades on a smaller diameter trowel.

2.4 Sound and Vibration Data

The required sound specification, Paragraph 1.7.4.f of 89/392/EEC Machinery Directive, is:

- the sound pressure level at operator's location (L_{pA}) : "A" dB(A)
- the guaranteed sound power level (L_{WA}) = "B" dB(A)

These sound values were determined according to ISO 3744 for the sound power level (L_{WA}) and ISO 6081 for the sound pressure level (L_{pA}) at the operator's location.

- The weighted effective acceleration value, determined according to ISO 8662 Part 1, is: "C" m/s^2 .

The sound and vibration specifications were obtained with the unit operating on wetted and cured concrete at full engine speed.

Model	Item No.	A	B	C
CT 36-5A	0009438 0620106	103	89	5.3
CT 36-6	0009443	103	89	5.3
CT 36-8A	0009439	109	95	4.3
CT 36-8A-V	0009442	109	95	4.0
CT 36-9	0009444	109	95	7.1
CT 36-9-V	0009447	109	95	6.6
CT 48-8A	0009449	109	95	5.3
CT 48-9	0009453	109	95	5.3
CT 48-11A	0009450	113	96	7.1
CT 48-13A-V	0009452	115	98	4.1

3. Operation

3.1 Application

This trowel is a modern, high production machine intended for floating and finishing freshly poured concrete slabs. The machine's good balance, adjustable handle, and easily reached controls add to operator comfort and productivity. An automatic stop sensor provides added operator safety. Finishing rates will depend on operator skill and job conditions.

DO NOT use this machine for any application other than troweling concrete.

3.2 New Machine Set-up

Trowels are shipped from the factory with the handle removed. Follow instructions on *Installing Blades* and *Installing and Adjusting Handles* when setting up new machines or when installing new handles and blades.

3.3 Recommended Fuel

The engine requires regular grade unleaded gasoline. Use only fresh, clean gasoline. Gasoline containing water or dirt will damage fuel system. Consult engine Owner's Manual for complete fuel specifications.

3.4 Installing Blades

See Graphic: wc_gr003238

There are four types of blades available for the trowels. Float pans are large "pizza pan" style blades, which hook on over finish or combination blades and are available for the 36" machines only. Float blades are available for all machines and clip on over finish or combination blades. Both are used in the earliest stages of work, and are not pitched.

Finish blades are used in the final stages of working, and are progressively pitched to burnish the concrete.

Combination blades can be used throughout the concrete working process. They are used in place of float blades or pans and finish blades.

Note: Trowel blades must NOT be interchanged, i.e., do NOT put larger diameter blades on a smaller diameter trowel.

- 3.4.1 Finish blades are flat on both edges and can be installed in either direction.

When installing combination blades, orient blades as shown **(a)**. This positions the raised edges of the blade correctly for the clockwise rotation of the machine.

- 3.4.2 Secure blades to trowel arms with screws **(b)**. Dip threads of screws in grease prior to installation. This will prevent concrete from cementing the screws in place and will make removal of the blades easier later on.

- 3.4.3 Plug the remaining threaded holes in the blade brace with plastic plugs **(c)** to prevent them from filling with concrete.



Do not lift the trowel overhead with a float pan attached, as the pan could fall off and strike personnel working in the vicinity.

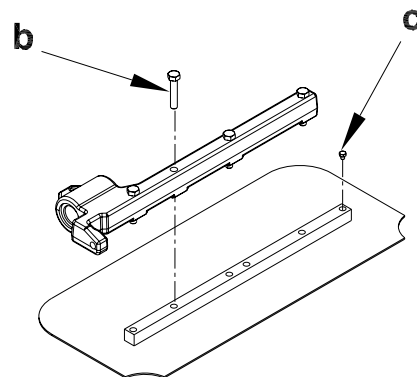
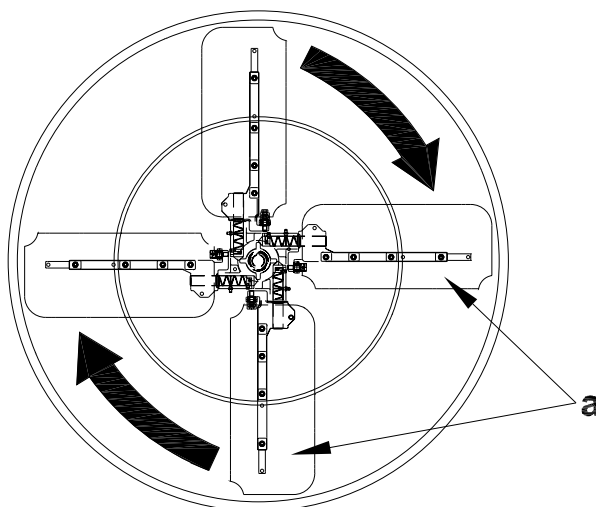

wc_gr003238

3.5 Installing and Adjusting Handles

See Graphic: *wc_gr001758, wc_gr003219*

On new machines the pipe handle comes assembled with the pitch control (Twist or *Pro-Shift*®) (c), stop button (b), throttle (a), screws (g), and nut (m).

To install the pipe handle assembly:

- 3.5.1 On machines with the foldable handle, straighten the handle and tighten the knob (e) to secure the handle in position.
- 3.5.2 Pull the pitch control cable (j) from bottom end of the tube and remove the nut from the cable.
- 3.5.3 Thread the cable through the handle base (f) and over the pulley (h) as shown.
- 3.5.4 Attach the pipe handle to the handle base with two M8x65 screws (g). Torque the screws to 25 Nm (18 ft.lbs.).
- 3.5.5 Push the *Pro-Shift*® handle all the way forward (away from the operator) OR turn the twist pitch control handle counterclockwise as far as possible. Connect the cable to the fork (k) as shown and adjust the cable nut (m) so the cable is snug and the trowel blades lay flat (0° pitch).
- 3.5.6 Move throttle (a1) to idle position. Remove air cleaner cover. Feed cable through clamp on recoil cover. Connect throttle cable to engine throttle bracket by placing z-bend through hole in throttle plate. Clamp cable into throttle casing bracket. Replace air cleaner cover.
- 3.5.7 Connect electrical wire on handle to both ends of the engine wire. See handle instruction sheet for additional detail on installation.
Note: *On machines with Wacker engines, do not connect wires in bag to wires in handle.*
- 3.5.8 On machines with an adjustable handle, position the handle by loosening the knob (d) and adjusting the handle up or down to suit the operator. Tighten the knob to secure the handle in position.

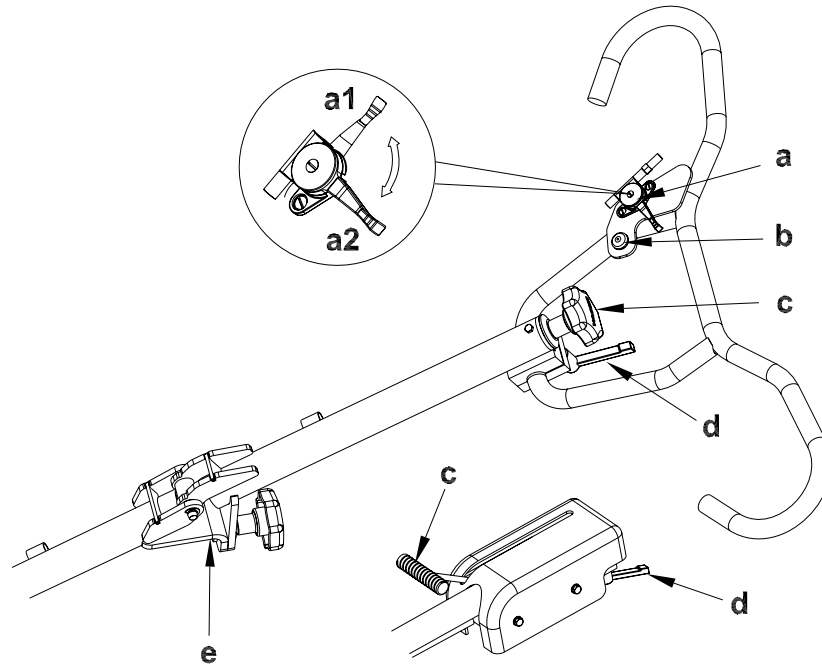

wc_gr003219

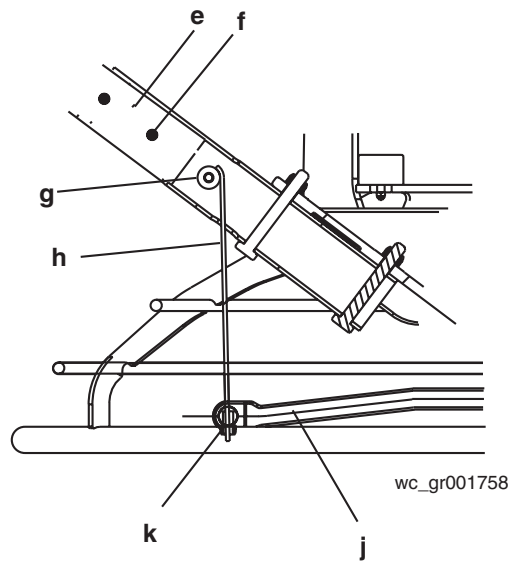

wc_gr001758

3.6 Controls

See Graphic: wc_gr003219

Ref.	Description	Ref.	Description
a	Throttle lever	d	Handle height adjustment (if equipped)
b	Stop button	e	Foldable handle adjustment (if equipped)
c	Twist pitch control or Pro-Shift® pitch control		

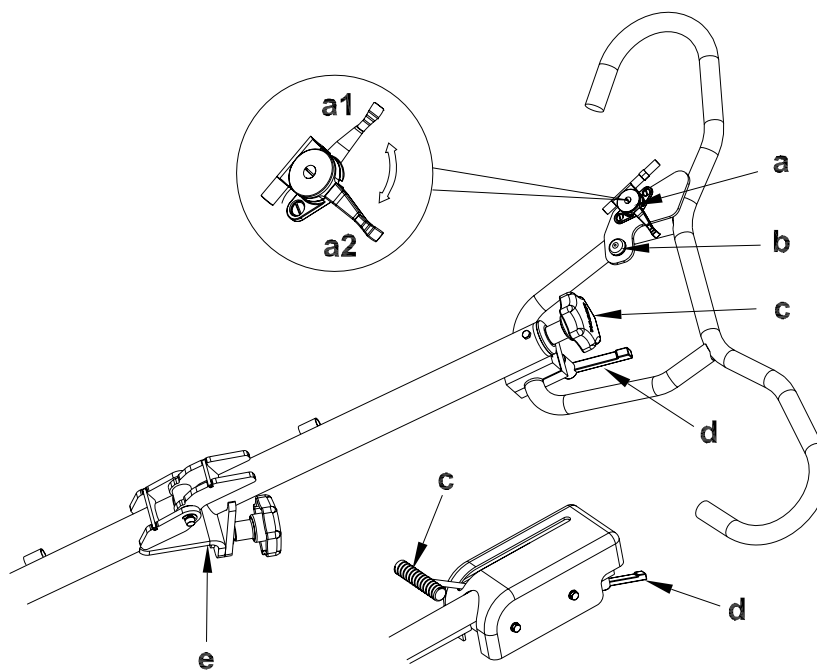

wc_gr003219

3.7 Stop Button

See Graphic: *wc_gr003219*

When the stop button **(b)** is pressed, the engine will shut off.

To prevent uncontrolled spinning of the trowel, the engine control module is designed to shutoff the engine under certain conditions. For example, if the operator loses his/her grip on the trowel, the engine control module will sense that the machine is spinning and shut off the engine. The momentum of the spinning trowel will engage the brake and stop the handle from spinning past 270°.

3.8 Before Starting

Before starting trowel, check the following:

- oil level in engine
- oil level in gearbox
- fuel level
- condition of air filter
- condition of fuel lines
- condition of trowel arms and blades
- condition of ring guard
- label descriptions
- handle height to suit operator

3.9 To Start - Honda

See Graphic: *wc_gr003219, wc_gr001098*

3.9.1 Open fuel valve by moving lever to the right **(g1)**.

Note: *If engine is cold, move choke lever to closed position (i1). If engine is hot, set choke to open position (i2).*

3.9.2 Turn engine switch to “ON” **(h1)**.

3.9.3 Move the throttle lever to the idle position **(a1)**.

Note: *Start engine with throttle in the idle position. If the engine is started when the throttle is not in the idle position, the engine should not start. This is a feature of the engine control module that prevents wide open throttle startup.*

3.9.4 Pull starter rope **(j)**.



Do not place foot on the ring guard when starting the engine, as severe injury can occur if foot slips through the ring guard as the blades start to spin.

Note: *If the engine oil is low, the engine will not start. If engine does not start, check the oil level and add oil as needed.*

3.9.5 Open choke as engine warms **(i2)**.

3.9.6 Open throttle **(a2)** to operate trowel. Adjust blade RPM with throttle speed to suit conditions.

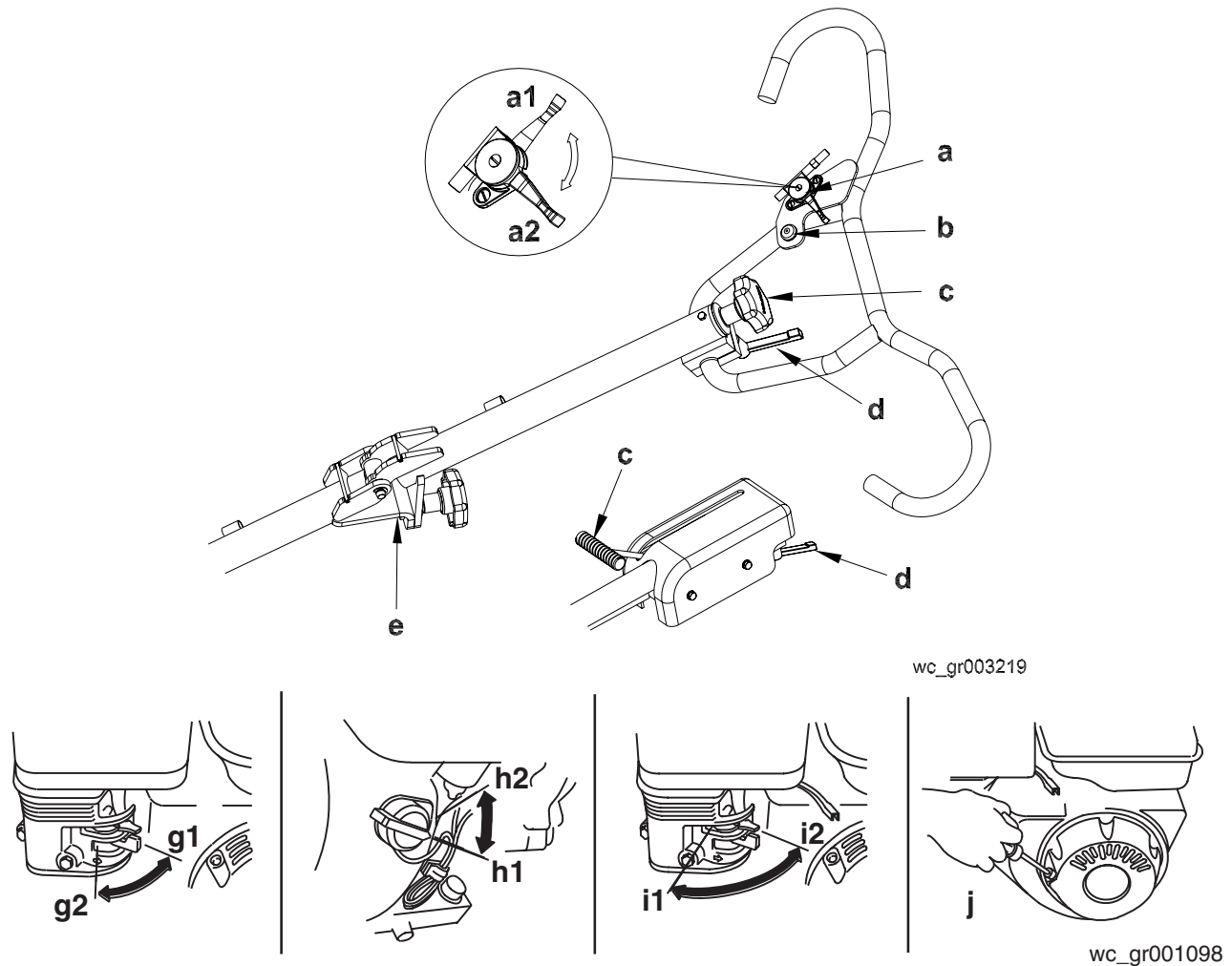

3.10 To Stop - Honda

See Graphic: *wc_gr003219*, *wc_gr001098*

- 3.10.1 Reduce engine RPM to idle by moving the throttle lever to idle position **(a1)**.
- 3.10.2 Push the stop button **(b)**.
- 3.10.3 Turn engine switch to "OFF" **(h2)**.
- 3.10.4 Close fuel valve by moving lever to the left **(g2)**.

3.11 To Start - Wacker

See Graphic: *wc_gr003219, wc_gr002747*

3.11.1 Open fuel valve by moving lever down **(g1)**.

Note: *If engine is cold, move choke lever to close position **(i2)**. If engine is hot, set choke to open position **(i1)**.*

3.11.2 Turn engine switch to "ON" **(h2)**.

3.11.3 Move the throttle lever to the idle position **(a1)**.

Note: *Start engine with throttle in the idle position. If the engine is started when the throttle is not in the idle position, the engine should not start. This is a feature of the engine control module that prevents wide open throttle startup.*

3.11.4 Pull starter rope **(j)**.



Do not place foot on the ring guard when starting the engine, as severe injury can occur if foot slips through the ring guard as the blades start to spin.

Note: *If the engine oil is low, the engine will not start. If engine does not start, check the oil level and add oil as needed.*

3.11.5 Open choke as engine warms **(i1)**.

3.11.6 Open throttle **(a2)** to operate trowel. Adjust blade RPM with throttle speed to suit conditions.

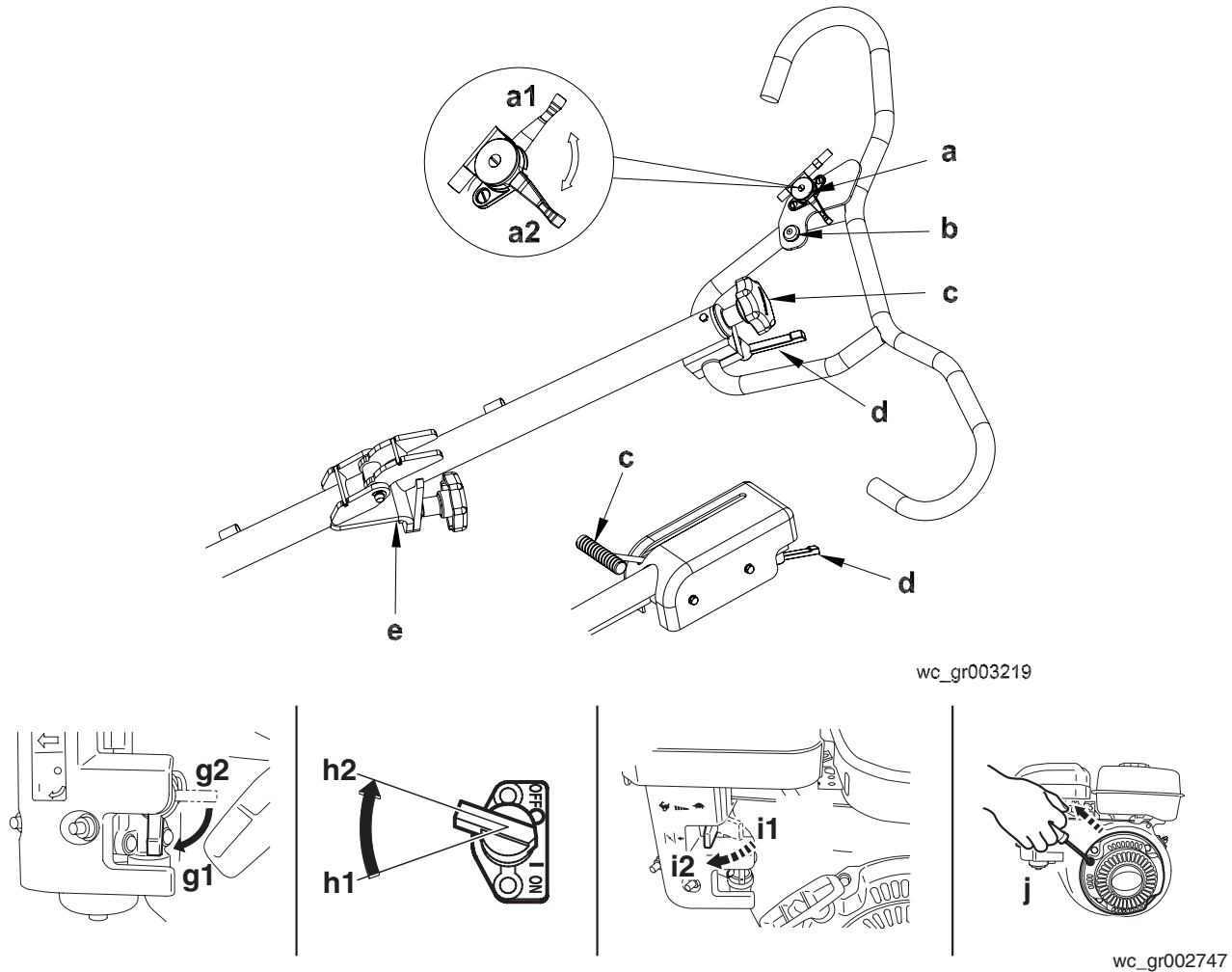

3.12 To Stop - Wacker

See Graphic: *wc_gr003219*, *wc_gr002747*

- 3.12.1 Reduce engine RPM to idle by moving the throttle lever to idle position (**a1**).
- 3.12.2 Push the stop button (**b**).
- 3.12.3 Turn engine switch to "OFF" (**h1**).
- 3.12.4 Close fuel valve (**g2**).

3.13 Engine Control Module

To prevent uncontrolled spinning of the trowel, the engine control module is designed to shutoff the engine under certain conditions. For example, if the operator loses his/her grip on the trowel, the engine control module will sense that the machine is spinning and shut off the engine. The momentum of the spinning trowel will engage the brake and stop the handle from spinning past 270°.

To test the engine control module, start the machine and jerk the handle to the right. The engine should stop. If the engine does not stop, repeat the jerking motion until the engine stops. If the engine does not shut off, push the stop button and turn the engine off. **DO NOT** operate the machine until the engine control module is replaced.



WARNING

DO NOT operate the trowel if the engine control module is disconnected or not functioning properly.

3.14 Operation

See Graphic: *wc_gr003239*



WARNING

ALWAYS test the function of the engine control module before operating the trowel. DO NOT operate the trowel if the engine control module is not functioning properly.

Choose correct blade type and attach blades to trowel arms. Do not mix float or finish blades with combination blades.

Note: *When operating on soft concrete, do not let trowel stand in one spot too long. Always lift trowel from slab when operation is complete.*

Note: *“Left” and “Right” references are made from the operator’s position.*

3.14.1 Adjust handle height to suit operator. See *Installing and Adjusting Handles*.

NOTICE: Do not attempt to adjust handle height on the trowel while it is running.

3.14.2 Start engine and engage blades by increasing engine speed. Set speed with throttle control on handle bar to appropriate speed for job conditions.

3.14.3 To move trowel forward twist handle clockwise **(a)**.

3.14.4 To move backward twist handle counterclockwise **(b)**.

3.14.5 To move to the left lift up slightly on the handle **(c)**.

3.14.6 To move to the right press down slightly on the handle **(d)**.

3.14.7 Clean trowel after each use to remove concrete splatter.



Allow the muffler to cool before cleaning or servicing the machine. A hot muffler could ignite the fuel and start a fire.

It is recommended that each set of work passes be at 90° to the previous set of work passes. This will help prevent the creation of valleys in the slab surface.

For example, in the illustration, the second set of work passes **(2)** is 90° to the first set of work passes **(1)**.



Personnel other than the trowel operator should not be allowed in the work area, as severe injury can occur from contact with operating trowel blades.

Do not attempt to clean, service or perform adjustments on the trowel while it is running.

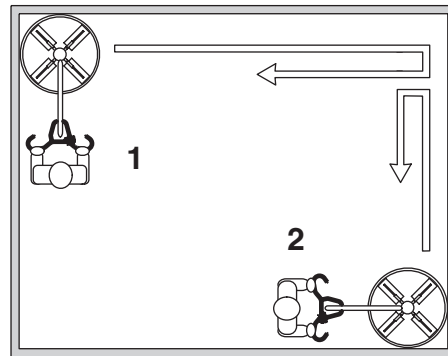
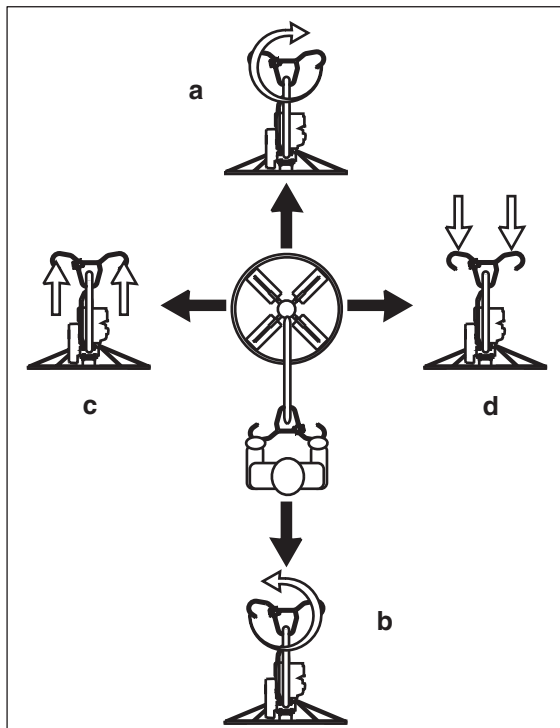

wc_gr003239

3.15 Braking System

The braking system of the trowel is spring loaded. The brake is engaged anytime the input shaft of the gearbox is not rotating and/or there is no resistance placed against the blades of the trowel. The brake is released when the input shaft is rotated and is shifted out from its seated position. This is accomplished when the gear on this shaft rotates, working against the output shaft gear, forcing the shaft out. If there is no or low resistance against the blades, the brake may not release as it is the resistance against the blades that allows the brake to release. If the machine is suspended or on a highly polished, slippery surface, the brake will not release and could cause belt slippage.

3.16 Pitch Adjustment

See Graphic: wc_gr003220

To adjust blade pitch (angle):

A = Twist pitch: turn the pitch adjusting knob **(a)** clockwise to increase pitch and counterclockwise to decrease pitch.

B = *Pro-Shift*[®]: pull the handle **(b)** towards the operator to increase pitch and away from the operator to decrease pitch.

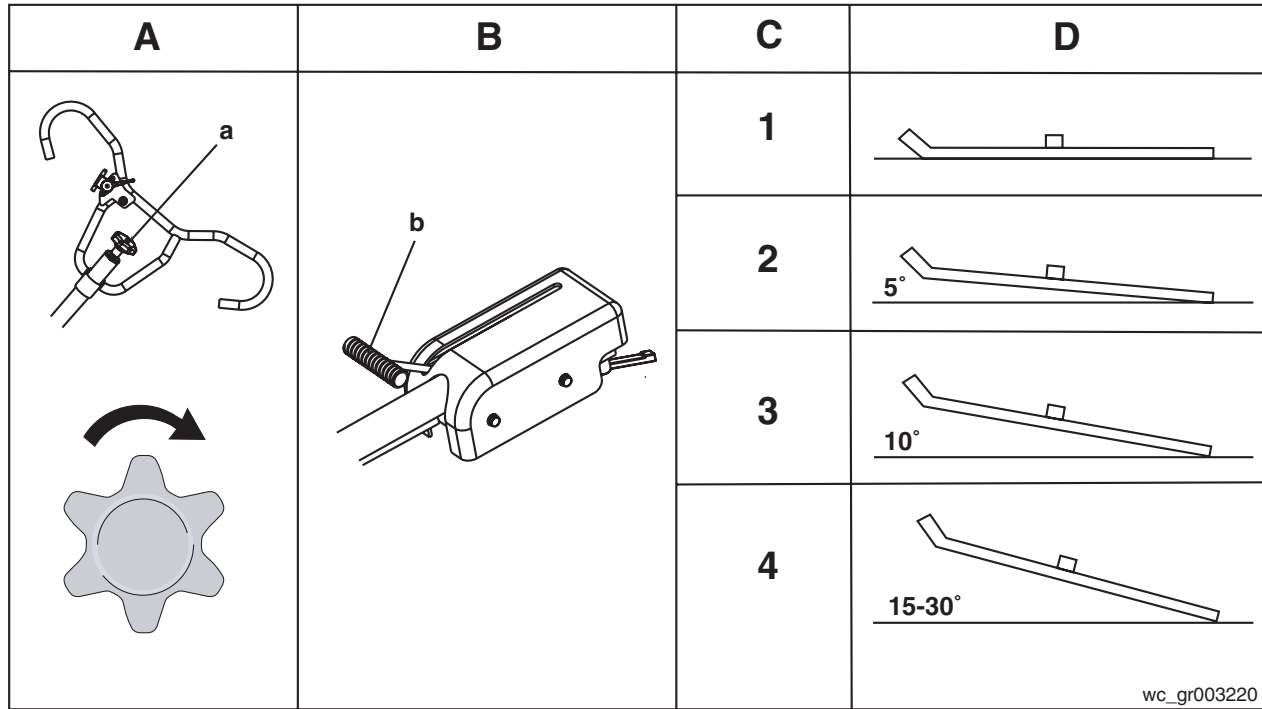

Ref.	C = Working condition of concrete	D = Suggested working pitch
1	Wet surface working stage	Flat (no pitch)
2	Wet to plastic working stage	Slight pitch (5°)
3	Plastic working stage	Additional pitch (10°)
4	Semi-hard working stage to hard finishing stage (burnishing)	Maximum pitch (15-30°)

For final finishing stages, it is sometimes desirable to add weights to the trowel guard rings to increase the burnishing force. Wacker supplies weight kits for this purpose.

4. Maintenance

4.1 Periodic Maintenance Schedule - Honda

The chart below lists basic machine and engine maintenance. Refer to the engine manufacturer's Operator's Manual for additional information on engine maintenance.

	Daily	After first 20 hrs.	Every 50 hrs.	Every 100 hrs.	Every 300 hrs.
Check fuel level.	■				
Check engine oil level.	■				
Inspect fuel lines.	■				
Inspect air filter. Replace as needed.	■				
Check external hardware.	■				
Clean trowel after each use to remove concrete splatter.	■				
Grease blade arms as needed.			■		
Clean air cleaner elements.			■		
Change engine oil.		■		■	
Check drive belt.				■	
Clean sediment cup.				■	
Check and clean spark plug.				■	
Check and adjust valve clearances.					■

4.2 Periodic Maintenance Schedule - Wacker

The chart below lists basic machine and engine maintenance. Refer to the engine manufacturer’s Operator’s Manual for additional information on engine maintenance.

	Daily	After first 20 hours	Every 2 weeks or 50 hrs.	Every month or 100 hrs.	Every year or 300 hrs.	Every 500 hrs.
Check fuel level.	■					
Check engine oil level.	■					
Inspect fuel lines.	■					
Inspect air filter. Replace as needed.	■					
Check external hardware.	■					
Clean trowel after each use to remove concrete splatter.	■					
Change engine oil.		■*				
Grease blade arms as needed			■			
Clean air cleaner elements.			■			
Clean sediment cup / fuel filter.				■		
Check and clean spark plug.				■		
Check and adjust valve clearance.					■	
Replace spark plug.						■

* Perform initially after first 20 hours of operation.

Maintenance, replacement or repair of emission control devices and systems may be performed by any repair establishment or individual.

4.3 Engine Oil - Honda

See Graphic: wc_gr002381

- 4.3.1 Drain oil while the engine is still warm.
- 4.3.2 Remove the oil fill plug (a) and drain cap (b) to drain oil.

Note: In the interests of environmental protection, place a plastic sheet and a container under the machine to collect any liquid which drains off. Dispose of this liquid in accordance with environmental protection legislation.

- 4.3.3 Install drain cap.
- 4.3.4 Fill the engine crankcase with recommended oil up to the level of the plug opening (c). See *Technical Data* for oil quantity and type.
- 4.3.5 Install the oil filler plug.

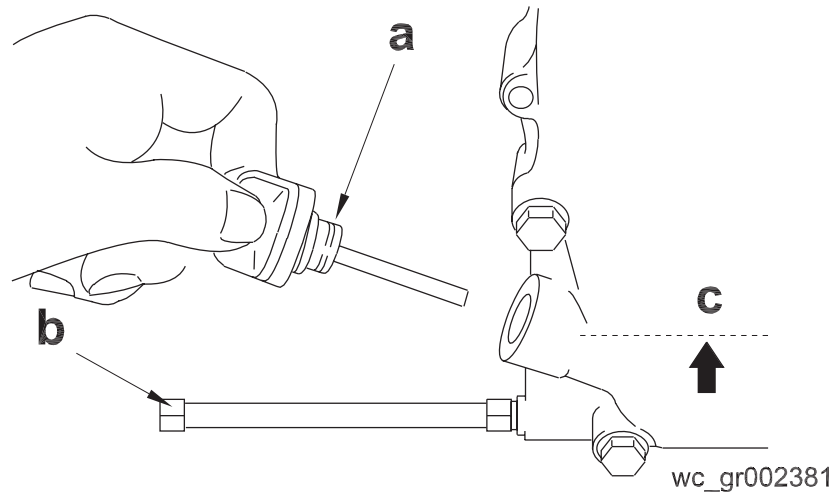

4.4 Engine Oil - Wacker

See Graphic: *wc_gr003201*

4.4.1 Drain oil while engine is still warm.

Note: *In the interests of environmental protection, place a plastic sheet and a container under the machine to collect any liquid which drains off. Dispose of this liquid in accordance with environmental protection legislation.*

4.4.2 Remove the oil drain cap **(a)**.

4.4.3 Allow the oil to drain.

4.4.4 Install the drain cap.

4.4.5 Fill the engine crankcase through the oil filler opening **(b)**, to the upper mark on the dipstick **(c)**. Do not thread in the dipstick to check the level. See *Technical Data* for oil quantity and type.

4.4.6 When the crankcase is full, reinstall the dipstick.

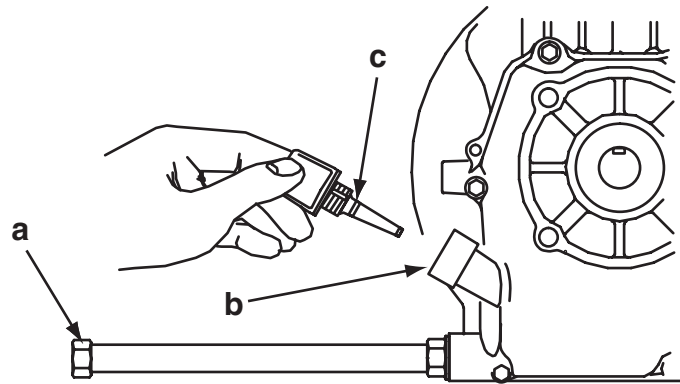

wc_gr003201

4.5 Air Cleaner - Honda

See Graphic: *wc_gr000025*

The engine is equipped with a dual element air cleaner. Service air cleaner frequently to prevent carburetor malfunction.

NOTICE: NEVER run engine without air cleaner. Severe engine damage will occur.



NEVER use gasoline or other types of low flash point solvents for cleaning the air cleaner. A fire or explosion could result.

WARNING

To service:

- 4.5.1 Remove air cleaner cover (**a**). Remove both elements and inspect them for holes or tears. Replace damaged elements.
- 4.5.2 Wash foam element (**b**) in solution of mild detergent and warm water. Rinse thoroughly in clean water. Allow element to dry thoroughly. Soak element in clean engine oil and squeeze out excess oil.
- 4.5.3 Tap paper element (**c**) lightly to remove excess dirt. Replace paper element if it appears heavily soiled.

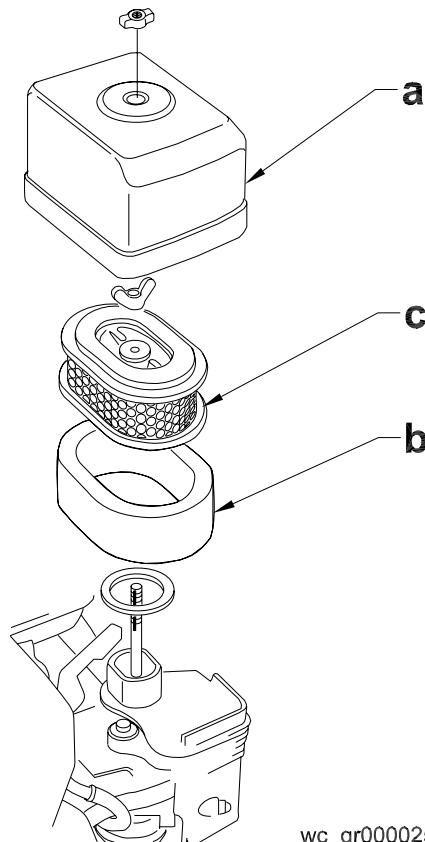

wc_gr000025

4.6 Air Cleaner - Wacker

See Graphic: *wc_gr000656*



WARNING

NEVER use gasoline or other types of low flash point solvents for cleaning the air cleaner. A fire or explosion could result.

NOTICE: NEVER run engine without air cleaner. Severe engine damage will occur.

The engine is equipped with a dual element air cleaner. Under normal operating conditions, elements should be cleaned once every week. Under severe, dry and dusty conditions, the elements should be maintained daily. Replace an element when saturated with dirt that cannot be removed.

- 4.6.1 Remove the air cleaner cover (**a**). Remove the filter assembly by pulling it straight up. Inspect both elements for holes or tears. Replace damaged elements.
- 4.6.2 Wash the foam element (**b**) in a solution of mild detergent and warm water. Rinse it thoroughly in clean water. Allow the element to dry thoroughly.
- 4.6.3 Tap the paper element (**c**) lightly to remove excess dirt or blow compressed air through the filter from the inside out. Replace the paper element if it appears heavily soiled.

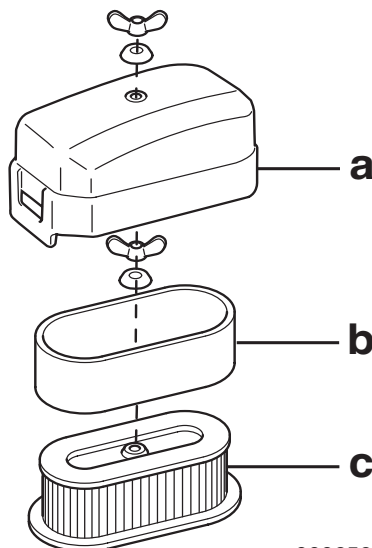

wc_gr000656

4.7 Spark Plug

See Graphic: wc_gr000028

Clean or replace the spark plug as needed to ensure proper operation. Refer to the engine owner's manual.



WARNING

The muffler becomes very hot during operation and remains hot for a while after stopping the engine. Do not touch the muffler while it is hot.

Note: Refer to the Technical Data for the recommended spark plug type and the electrode gap setting.

- 4.7.1 Remove the spark plug and inspect it.
- 4.7.2 Replace the spark plug if the insulator is cracked or chipped.
- 4.7.3 Clean the spark plug electrodes with a wire brush.
- 4.7.4 Set the electrode gap (**a**).
- 4.7.5 Tighten the spark plug securely.

NOTICE: A loose spark plug can become very hot and may cause engine damage.

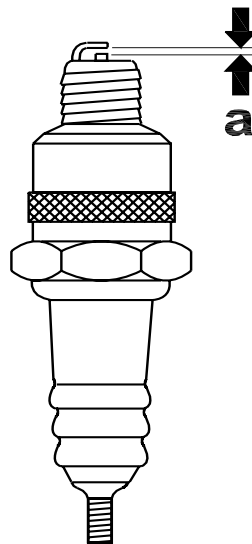

4.8 Cleaning Sediment Cup - Honda

See Graphic: *wc_gr000029*

- 4.8.1 Turn the fuel valve off.
- 4.8.2 Remove the sediment cup **(a)** and the O-ring **(b)**.
- 4.8.3 Wash both thoroughly in a nonflammable solvent. Dry and reinstall them.
- 4.8.4 Turn the fuel valve on and check for leaks.

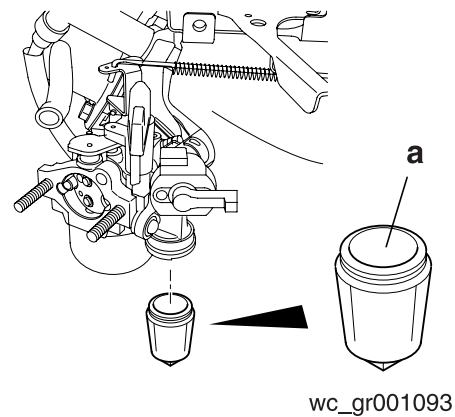
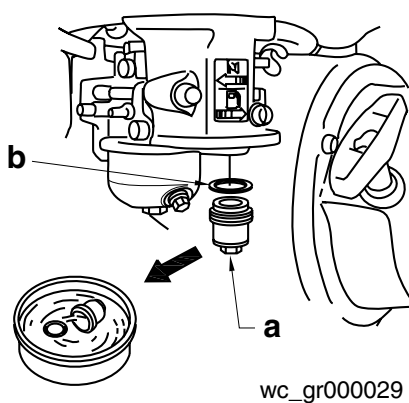

4.9 Cleaning Fuel Strainer - Wacker

See Graphic: *wc_gr001093*

- 4.9.1 To remove water and dirt, close the fuel lever and remove the fuel strainer.
- 4.9.2 Inspect the fuel strainer **(a)** for water and dirt.
- 4.9.3 After removing any dirt and water, wash the fuel cup with a nonflammable solvent.
- 4.9.4 Reinstall securely to prevent leakage.

4.10 Adjusting Idle Speed - Honda

See Graphic: wc_gr001122



Remove the drive belt before making any adjustment to the carburetor. See *Belt Replacement*. The blades will engage unless the belt is removed from the machine.

Adjust engine to the no load or idle speed per the Technical Data.

- 4.10.1 Start the engine and allow it to warm up to normal operating temperature.
- 4.10.2 Turn the throttle stop screw **(a)** in to increase speed, out to decrease speed. Make sure the throttle lever is touching the stop screw before measuring rpm.

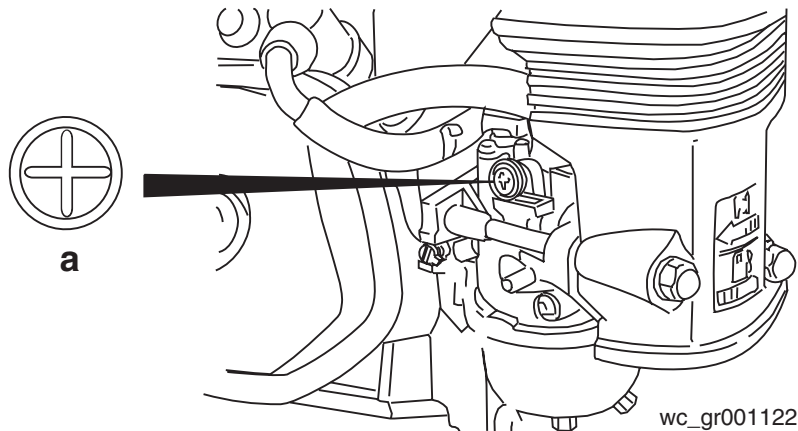

4.11 Carburetor Adjustment - Honda

See Graphic: *wc_gr0001061*



Remove the drive belt before making any adjustment to the carburetor. See *Belt Replacement*. The blades will engage unless the belt is removed from the machine.

The pilot screw **(a)** is fitted with a limiter cap to prevent excessive enrichment of the air-fuel mixture in order to comply with emission regulations. The mixture is set at the factory and no adjustment should be necessary. Do not attempt to remove the limiter cap. The limiter cap cannot be removed without breaking the pilot screw.

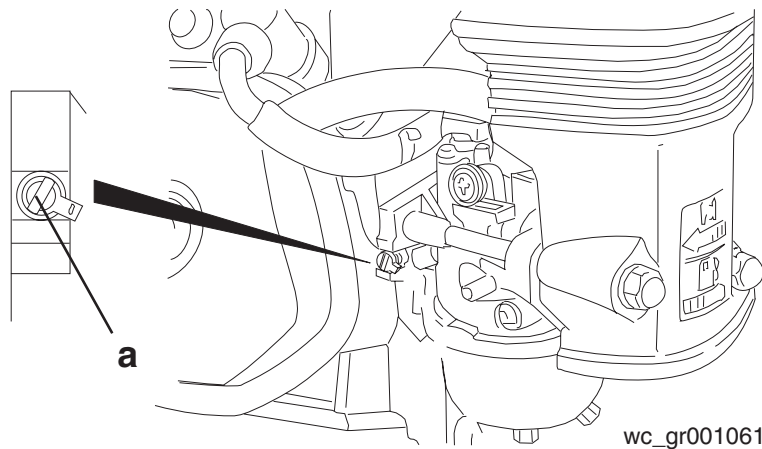

4.12 Belt Replacement

See Graphic: *wc_gr002380*, *wc_gr003221*

The trowel is equipped with a self-adjusting clutch. This clutch automatically tightens the belt and compensates for belt wear. Replace the belt if the clutch can no longer tighten belt enough to engage gearbox without slipping.

To replace the drive belt:

- 4.12.1 Disconnect the spark plug lead.



WARNING

To avoid accidental starting of the engine, always disconnect the spark plug lead before working on machine.

- 4.12.2 Loosen the screws (**d**) and remove the belt guard (**c**).

- 4.12.3 Slowly turn the pulley (**b**) and roll the belt (**a**) off.

Note: *The clutch and the pulley are aligned at the factory and neither should be removed during belt replacement.*

- 4.12.4 Install the new belt.

- 4.12.5 Reattach the belt guard with washers and screws. Torque the screws to 5 Nm (3.7 ft.lbs.).

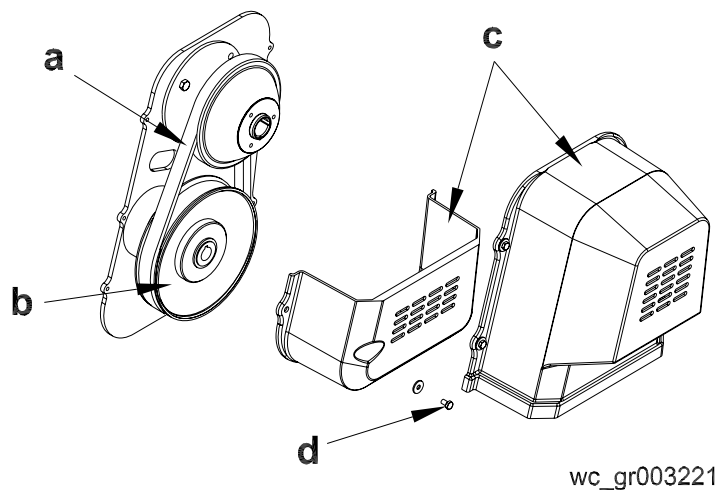
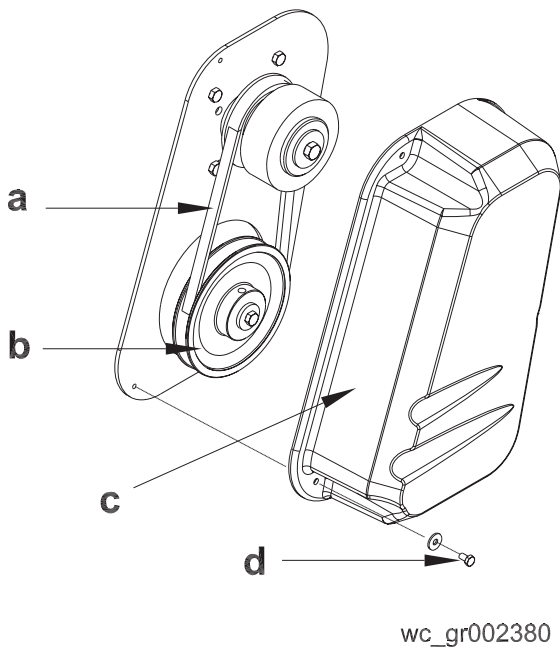

4.13 Trowel Lubrication

See Graphic: *wc_gr001755*

Grease trowel arms (**b**) with Shell Alvania RL2 grease or equivalent. Oil the pitch control cable and other parts of trowel on an as needed basis.

Oil in the gearbox should not require replacement unless it was drained to service gearbox. Check quantity through plug (**a**) located on side of gearbox. Oil level should be to bottom of the plug threads. See *Technical Data* for oil quantity and type.

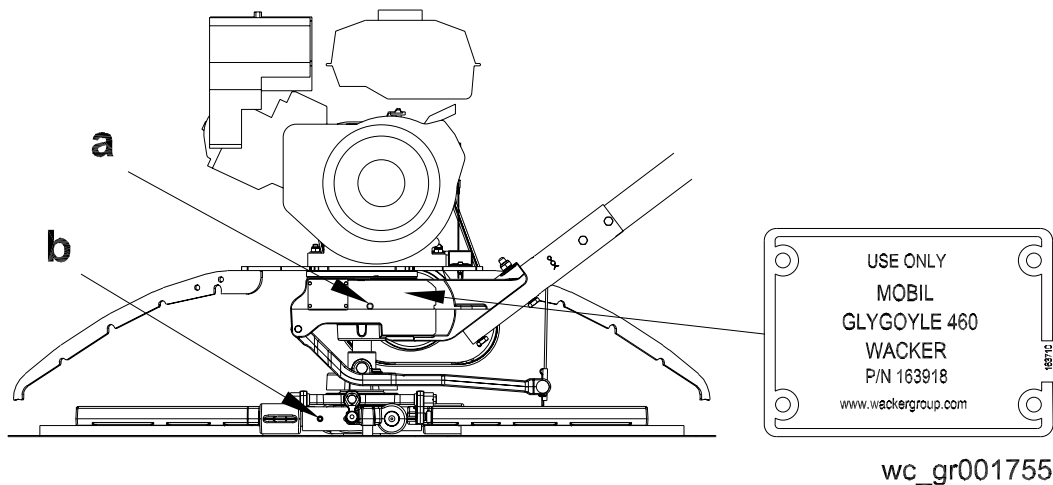

4.14 Optional Weights

To install optional weights, place equal number of weights in both front and rear of guard ring in designated area. Tighten screw to keep weights in place.



Under no circumstances should any object be used as additional weight other than the weights recommended by Wacker. The use of unauthorized weights could lead to personal injury or machine damage.

4.15 Lifting

See Graphic: wc_gr001762



NEVER lift the machine solely by the handle. The component may fail, causing the machine to fall, possibly injuring bystanders.

See *Technical Data* for the weight of the machine.

To lift the machine manually:

- 4.15.1 Stop engine.
- 4.15.2 Obtain a partner and plan the lift.
- 4.15.3 Balance the weight between the partners and lift the machine by the guard ring **(a)**, or proceed as follows:
 - a. Attach optional lifting bracket **(c)** to trowel with screws and locknuts. Torque screws to 25 Nm (18 ft.lbs.).
 - b. Insert a 2x4 or other suitable lumber into the bracket. The lumber must be long enough to extend past the ring guard.
 - c. Balance the weight between the partners and lift the machine by the handle and the lumber.



To reduce risk of back injury while lifting, keep your feet flat on ground and shoulder width apart. Keep your head up and back straight.

To lift the machine mechanically:

- 4.15.4 Stop engine.
- 4.15.5 See *Dimensions and Weight* for weight of machine and be sure that lifting device(s) can safely lift the weight.
- 4.15.6 Attach optional lifting bracket **(b)** to trowel with screws and locknuts. Torque to 25 Nm (18 ft.lbs.).
- 4.15.7 Attach hook, harness, or cable to the lifting bracket on machine as shown and lift as desired.



Do not lift the trowel overhead with a float pan attached, as the pan could fall off and strike personnel working in the vicinity.

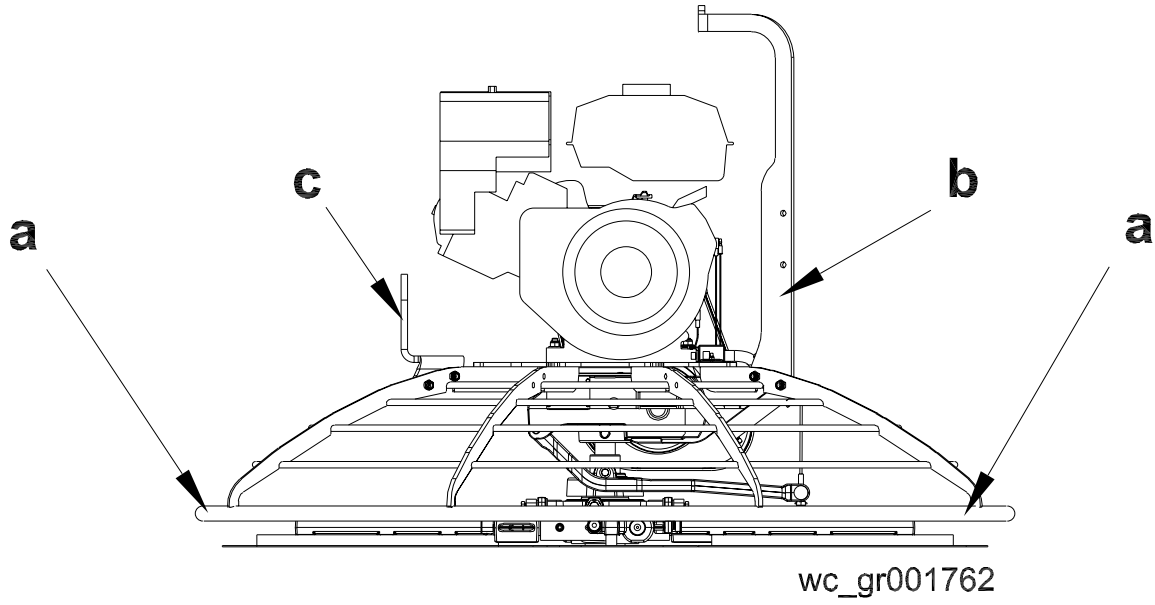

4.16 Storage

If trowel is being stored for more than 30 days:

- Change engine oil.
- Drain fuel from engine.
- Remove spark plug and pour 15 ml ($\frac{1}{2}$ ounce) of SAE 30 engine oil into the cylinder. Replace spark plug and crank engine to distribute oil. Refer to engine manual.
- Clean dirt from cylinder, cylinder head fins, blower housing, rotating screen, and muffler areas.
- To save space, place handle in its storage position.
- Cover trowel and engine and store in a clean, dry area.

4.17 Troubleshooting

Problem / Symptom	Reason / Remedy
Trowel does not develop full speed.	<ul style="list-style-type: none"> • Remove deposits built up in engine cylinder and engine head. • Engine speed too low. Adjust speed. • Clean or replace air filter. • Clean debris from moving parts and trowel blades. • In cold weather, warm engine in idle 3 or 4 minutes. • Check throttle lever and cable for proper operation.
Engine runs; poor trowel operation.	<ul style="list-style-type: none"> • Check drive belt for wear or damage. • Check clutch for wear or damage. • Clean debris from moving parts and trowel arms.
Engine does not start or runs erratically.	<ul style="list-style-type: none"> • Check fuel level. Open fuel valve. • Clean air filter. • Check/replace spark plug. • Check in-line fuel filter. • Check engine oil level. • Check engine stop button. • Check that throttle is in idle position when starting machine.
Trowel handle tends to rotate when idling.	<ul style="list-style-type: none"> • Check engine idle speed. (It may be too high). • Belt alignment may be off.

5. Guide Handle

5.1 Replacing the Throttle Cable

See Graphic: *wc_gr003362*

Disassembly:

- 5.1.1 Remove the engine air cleaner **(d)** if necessary to gain access to the throttle cable at the engine. Unclamp the throttle cable from the throttle casing clamp **(g)**.
- 5.1.2 Disconnect the throttle cable **(e)** from the engine throttle bracket **(f)**.
- 5.1.3 Pull the throttle cable through the cable guide **(c)** of the handle.
- 5.1.4 Remove the cable ties **(a)** from the handle.
- 5.1.5 Remove the screw and the casing fastener from the throttle control lever **(b)** and remove the throttle cable from the machine.

Assembly:

- 5.1.6 Place the engine's throttle control lever in the idle position. Connect the throttle cable **(e)** to the engine throttle bracket **(f)** by placing the Z-bend at the end of the cable through the hole in the throttle plate.
- 5.1.7 Using the throttle casing clamp **(g)** secure the throttle cable to the engine.
- 5.1.8 Push the opposite side of the throttle cable through the cable guide **(c)** of the handle.
- 5.1.9 Secure the throttle cable to the throttle control lever **(b)** and adjust it as needed. See section *Adjusting the Throttle Lever*.
- 5.1.10 Secure the throttle cable to the handle with new cable ties **(a)**.

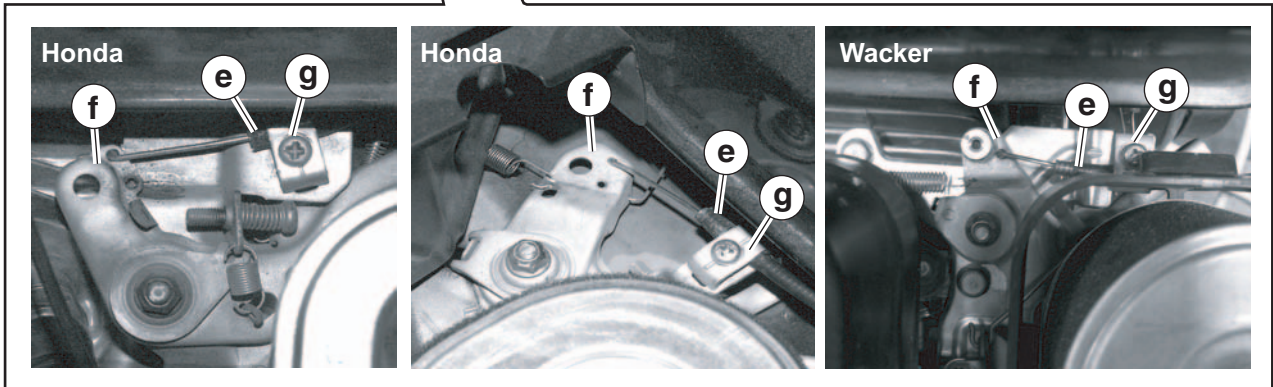
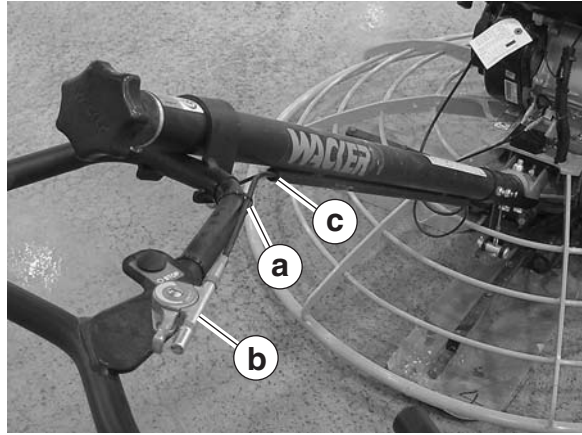
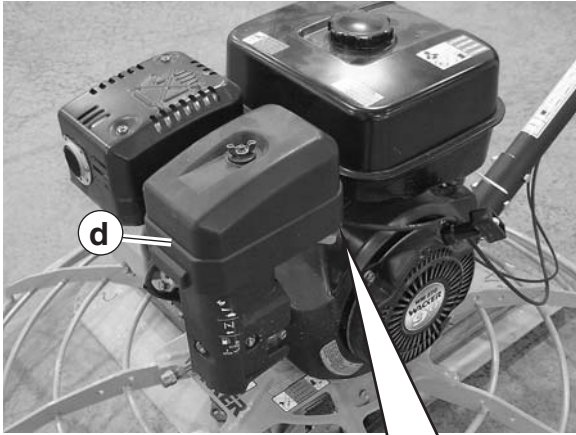

wc_gr003362

5.2 Adjusting the Throttle Lever

See Graphic: *wc_gr003361*

The throttle lever is used to vary the speed of the engine and to control the rpm of the trowel blades to meet specific applications and job conditions.

- 5.2.1 Be sure the engine's throttle control can obtain the idle (slow) position. If necessary, loosen the throttle casing clamp at the engine and reposition the throttle cable so that the engine's throttle control can reach the idle (slow) position.
- 5.2.2 Remove the screw **(a)** on top of throttle lever **(b)** and lift off the throttle lever.
- 5.2.3 Position the throttle lever in the idle (slow) position (1) (parallel with the body of the control body) so that it engages the teeth of the throttle cable **(c)**.
- 5.2.4 Remove the nut **(d)** and test the position of the throttle cable. When the throttle lever is at 90° (2) (perpendicular to the control body) two teeth should show outside the control body **(e)**. Adjust the position of the throttle lever as necessary.
- 5.2.5 Secure the throttle lever to the control body with the screw **(a)**.

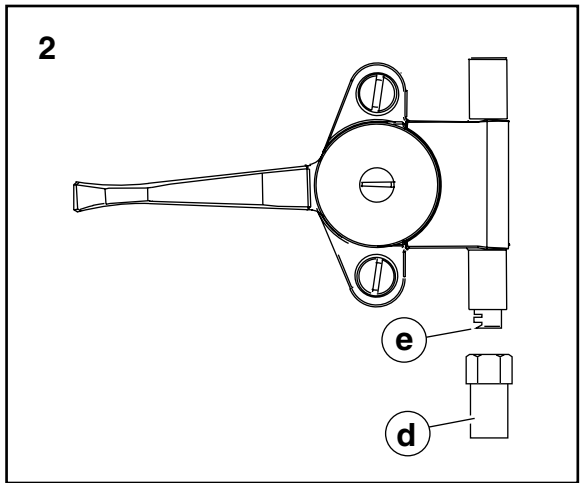
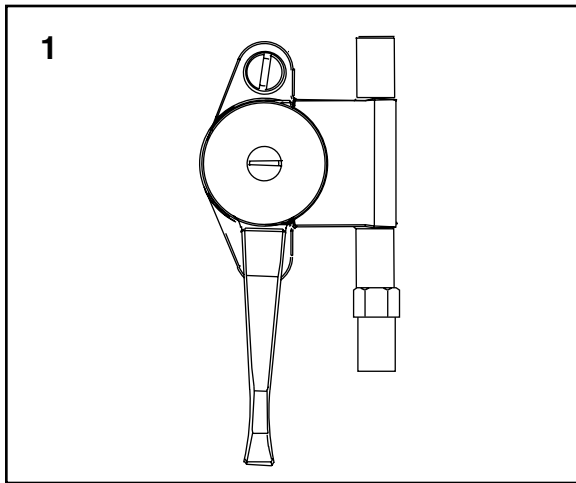
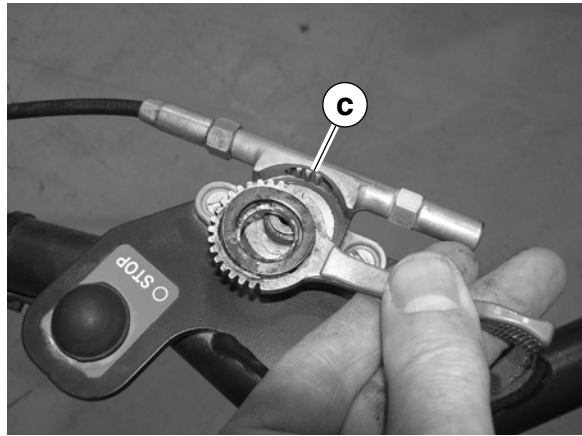
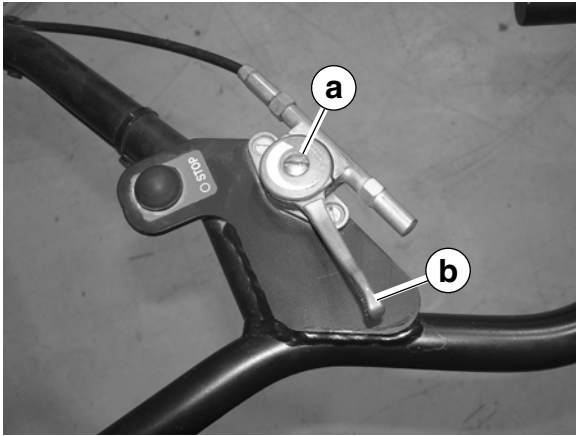

wc_gr003361

5.3 Upper Handle/Twist Pitch Control—Exploded View

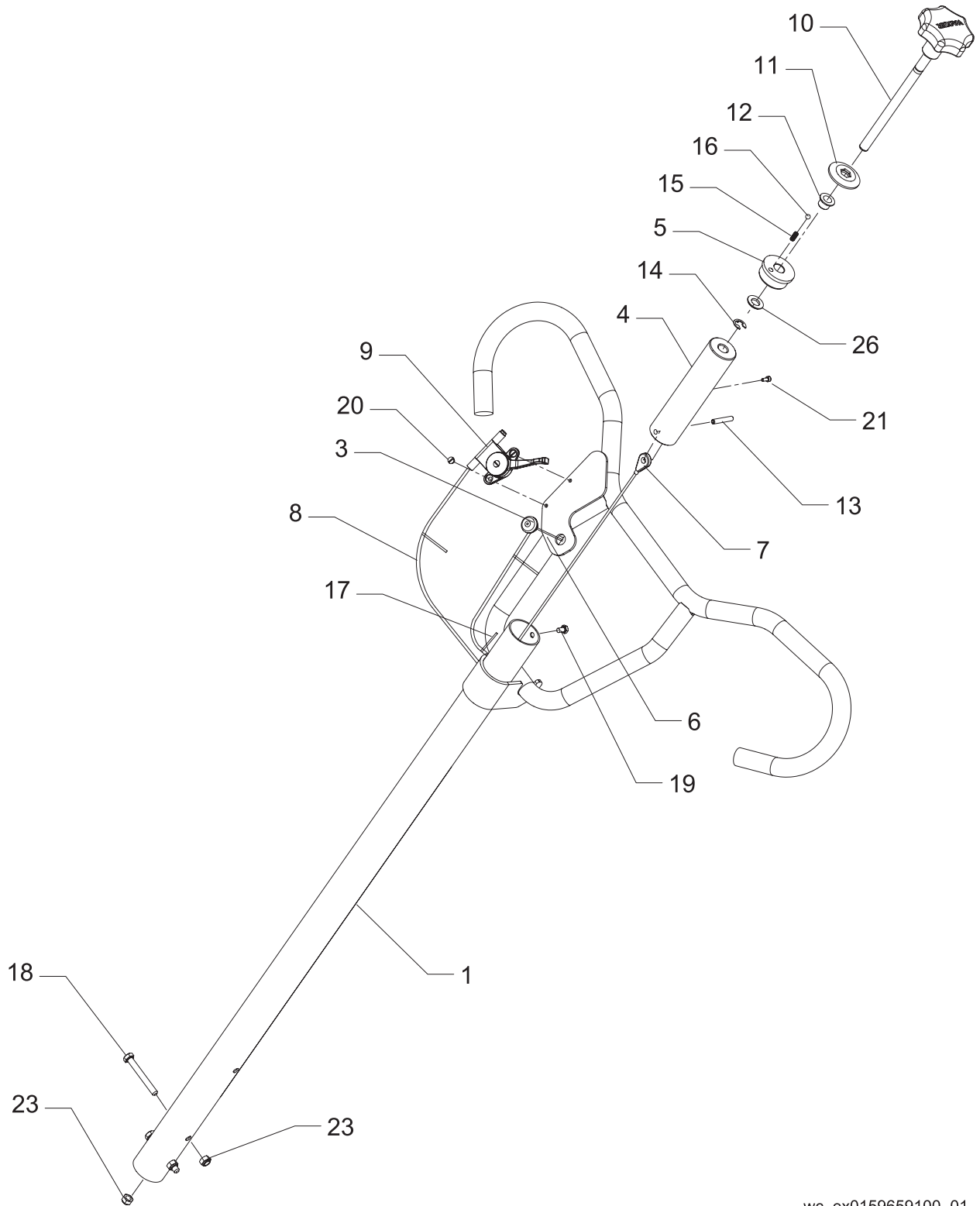

wc_ex0159659100_01

5.4 Upper Handle/Twist Pitch Control—Components

Ref.	Description	Ref.	Description
1	Handle	13	Pin
3	Push button switch	14	Retaining ring
4	Nut	15	Spring
5	Bearing holder	16	Ball
6	Wiring harness	17	Tie cable
7	Cable	18	Hex head screw
8	Throttle cable	19	Hex head screw
9	Kit-CT throttle	20	Flat head screw
10	Pitch control knob	21	Socket head screw
11	Plate	23	Locknut
12	Flange-bearing	26	Flat washer

5.5 Replacing the Upper Handle

See Graphic: *wc_gr003360*

Disassembly:

- 5.5.1 Remove the throttle lever **(a)** and the throttle cable from the upper handle. See section *Replacing the Throttle Cable*.
- 5.5.2 Disconnect and remove the stop switch **(b)**. See section *Replacing the Stop Switch*.
- 5.5.3 Disconnect the handle ground wire if equipped on your machine.
- 5.5.4 Remove the lock nut **(c)** from the end of the pitch control cable **(d)**. Pull the pitch control cable from the yoke **(e)** and slide it from the pulley **(f)** of the lower handle **(g)**.
- 5.5.5 Remove the two screws **(h)** holding the upper handle to the lower handle. Carefully pull the upper handle and the pitch control cable away from the lower handle.
- 5.5.6 Remove the pitch control device **(i)** (twist pitch or Pro-Shift[®]) and the pitch control cable from the upper handle.

Assembly:

- 5.5.7 Thread the pitch control cable through the upper handle. Attach the pitch control device **(i)** (twist pitch or Pro-Shift[®]) to the upper handle. On models with twist-pitch control, turn the knob counterclockwise as far as possible. On models with Pro-Shift[®] control, position the lever towards the operator.
- 5.5.8 Position the upper handle near the lower handle **(g)** so that you can thread the pitch control cable **(d)** through the lower handle and around the pulley **(f)** of the lower handle. Then, slide the upper handle into the lower handle.
- 5.5.9 Secure the upper handle to the lower handle with two screws **(h)** and lock nuts.
- 5.5.10 Thread the pitch control cable into the yoke **(e)** and connect the lock nut **(c)**. Adjust the lock nut so that the cable is snug with the trowel blades flat (0° pitch).
- 5.5.11 Attach (by threading) the stop switch **(b)** to the upper handle. See sections *Engine Wiring* and *Replacing the Stop Switch*.
- 5.5.12 Connect the handle ground wire if equipped on your machine.
- 5.5.13 Attach the throttle lever **(a)** and throttle cable. See section *Replacing the Throttle Cable*.

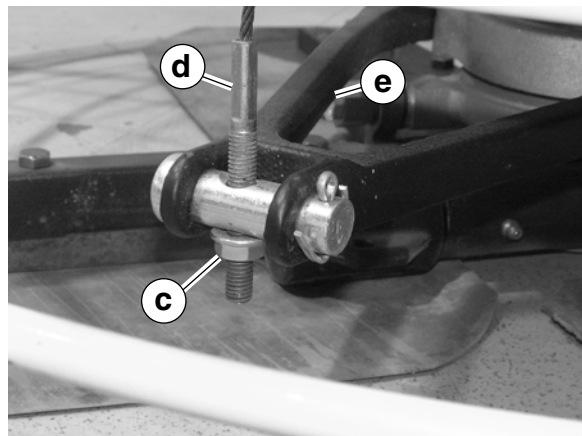
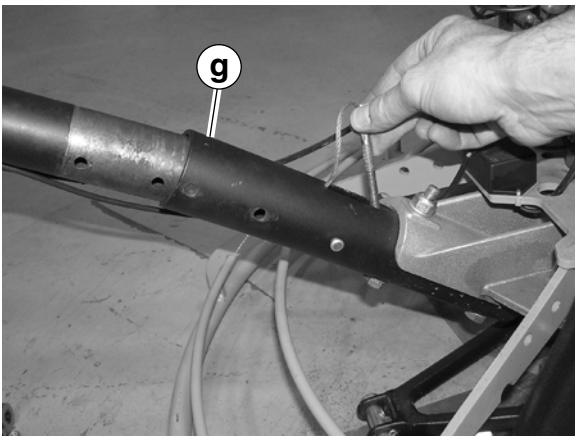
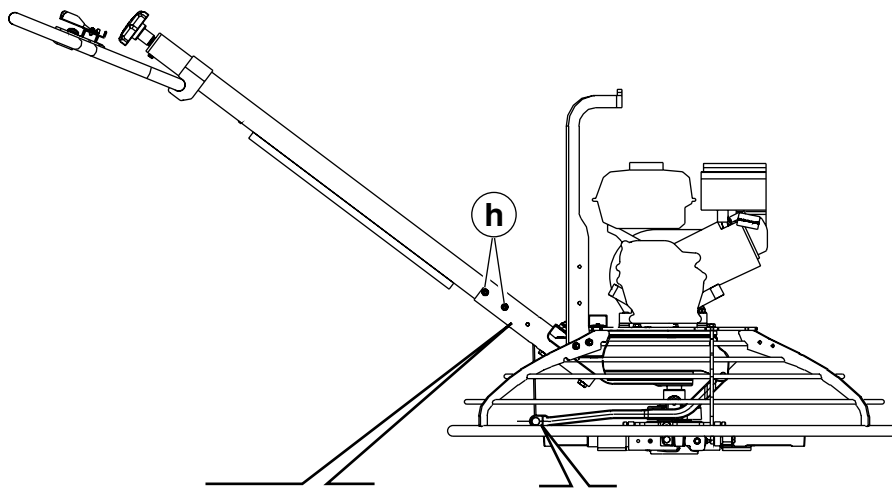
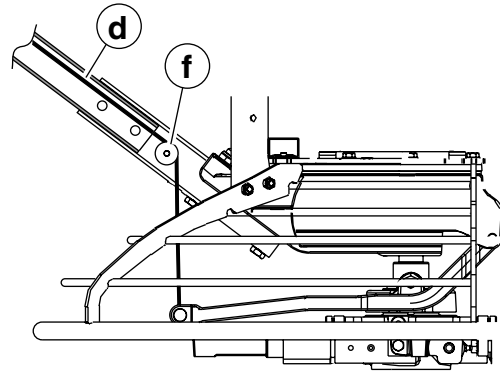
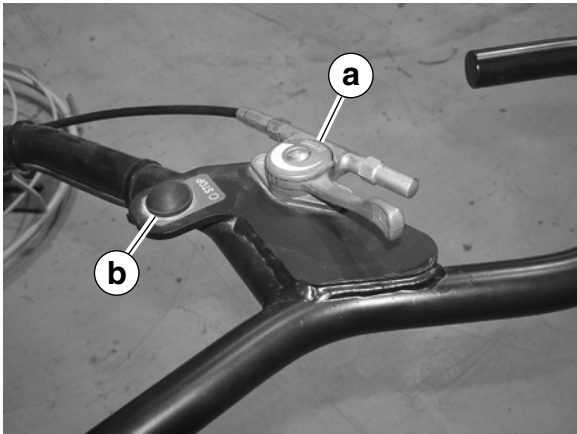

wc_gr003360

5.6 Replacing the Twist Pitch Control Cable

See Graphic: *wc_gr003363*

Disassembly:

- 5.6.1 Remove the upper handle. See section *Replacing the Upper Handle*.
- 5.6.2 Remove the hex head screw **(a)** from the handle and the socket head screw **(b)** from the underside of the twist control assembly **(c)**.
- 5.6.3 Pull the twist control assembly and the pitch control cable **(d)** from handle.
- 5.6.4 Drive the roll pin **(e)** from the twist control assembly. Remove the pitch control cable.

Assembly:

- 5.6.5 Attach the knob **(f)** to the twist control assembly **(c)**.
- 5.6.6 Place the pitch control cable **(d)** into the twist control assembly and secure it with the roll pin **(e)**.
- 5.6.7 Lubricate the threads **(g)** on the twist control assembly.
- 5.6.8 Slide the pitch control cable down through the handle and position the twist control assembly into the upper handle, lining up the holes in the twist control assembly with those of the handle. Attach the socket head screw **(b)** to the underside of the twist control assembly.
- 5.6.9 Apply Loctite 243 or equivalent to the threads of the hex head screw **(a)** and secure it to the handle. Torque the hex head screw to 10 Nm (7 ft.lbs.).
- 5.6.10 Replace the upper handle. See section *Replacing the Upper Handle*.

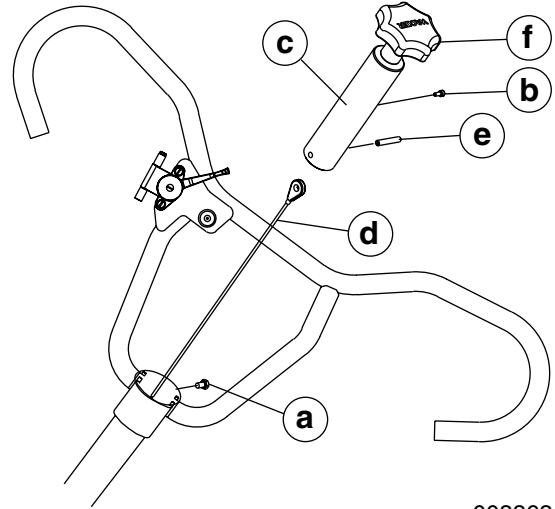
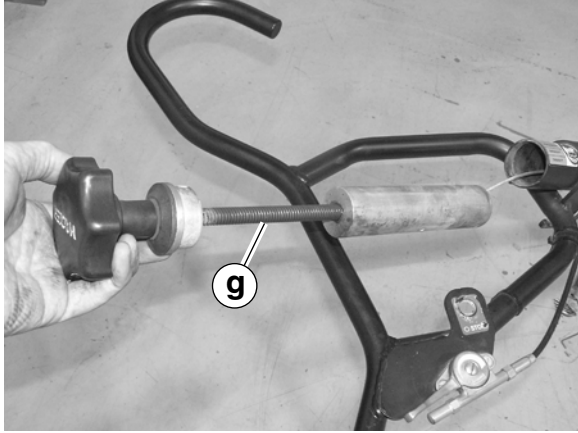

wc_gr003363

5.7 Replacing the Lower Handle

See Graphic: *wc_gr003156*

Disassembly:

- 5.7.1 Remove the upper handle. See section *Replacing the Upper Handle*.
- 5.7.2 Remove the two locknuts (80) and washers (73) from the screws (60).
- 5.7.3 Pull the lower handle (17) from the gearbox.
- 5.7.4 If replacing the pulley (25), pull the cotter pin (46) from the clevis pin (42) and remove the pulley.

Assembly:

- 5.7.5 If removed, replace the pulley (25) and reattach it with the clevis pin (42) and cotter pin (46).
- 5.7.6 Position the lower handle (17) into the gearbox and secure it with the screws (60), washers (73), and locknuts (80).
- 5.7.7 Install the upper handle. See section *Replacing the Upper Handle*.

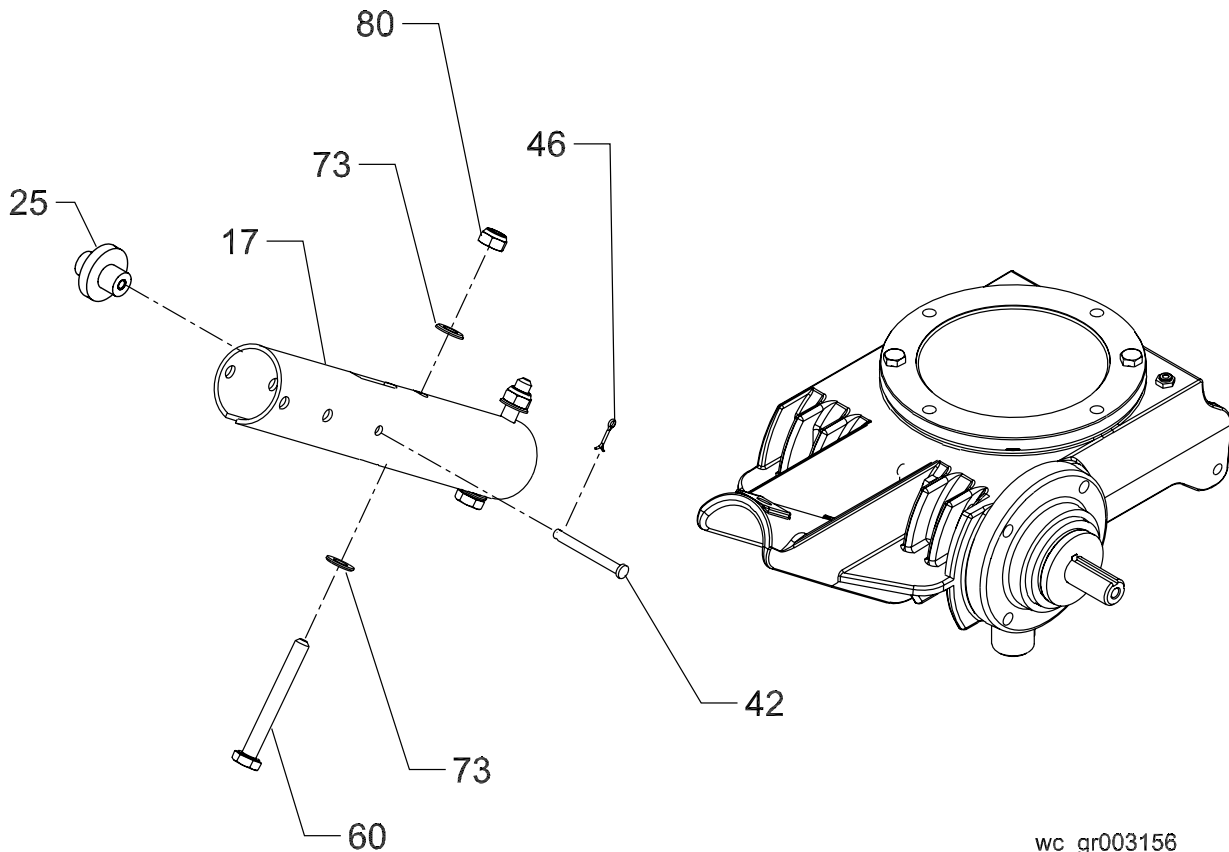

wc_gr003156

5.8 Replacing the Stop Switch

See Graphic: *wc_gr003371*

To replace the stop screw (a), carry out the following procedures:

Removal:

- 5.8.1 Remove the protective boot (b).
- 5.8.2 Disconnect the wire (c).
- 5.8.3 Unthread the stop switch from the handle.

Installation:

- 5.8.4 Thread the stop switch (a) into the handle.
- 5.8.5 Connect the wire (c).
- 5.8.6 Install the protective boot (b).

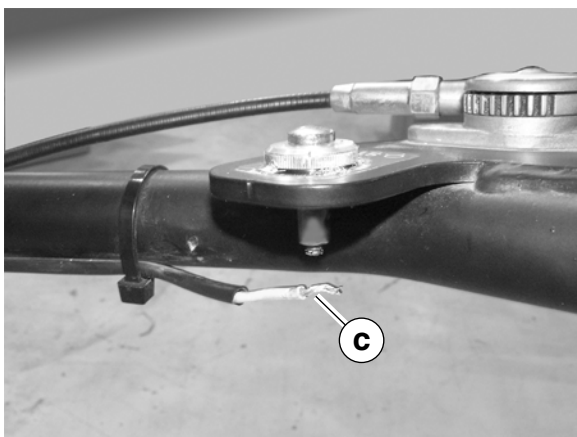
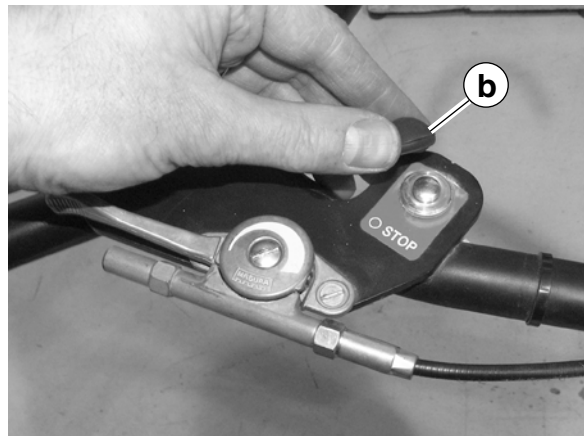
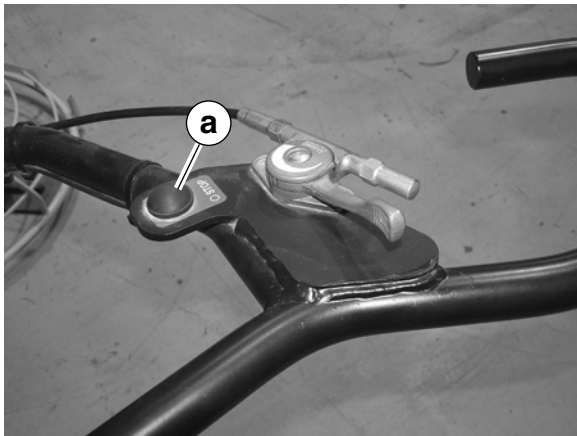

wc_gr003371

Notes

6. Clutch

6.1 Replacing the Drive Belt

See Graphic: *wc_gr003153* and *wc_gr003382*

The trowel is equipped with the standard self-adjusting clutch or a variable speed clutch. Replace the belt if the clutch can no longer tighten the belt enough to engage the gearbox without slipping. The procedure to change the belt is the same for both clutches.

To replace the drive belt:

- 6.1.1 Disconnect the spark plug lead.



WARNING

To avoid accidental starting of the engine, disconnect the spark plug lead before working on the machine.

- 6.1.2 Remove the screws and the washers that secure the beltguard and remove the beltguard.
- 6.1.3 Slowly turn the pulley and roll the belt off the pulley.
- 6.1.4 Slowly turn the pulley and roll the new belt on the pulley.
- 6.1.5 Reattach the beltguard with the washers and the screws. Torque the screws to 5 Nm (3.7 ft.lbs.).

6.2 Drive Belt—Standard Clutch

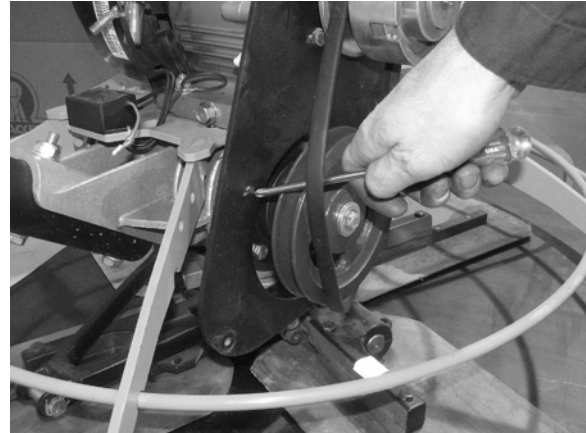
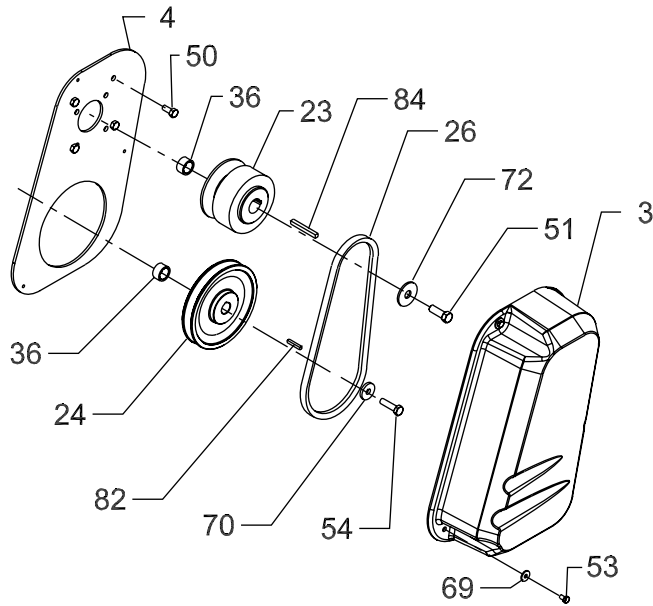

wc_gr003153

Ref.	Description	Ref.	Description
3	Beltguard	53	Hex head screw
4	Beltguard plate	54	Hex head screw
23	Clutch assembly	69	Fender washer
24	Pulley	70	Flat steel washer
26	V-belt	72	Washer
36	Spacer	82	Key
50	Screw	84	Key (square)
51	Hex head screw		

6.3 Drive Belt—Variable Speed Clutch

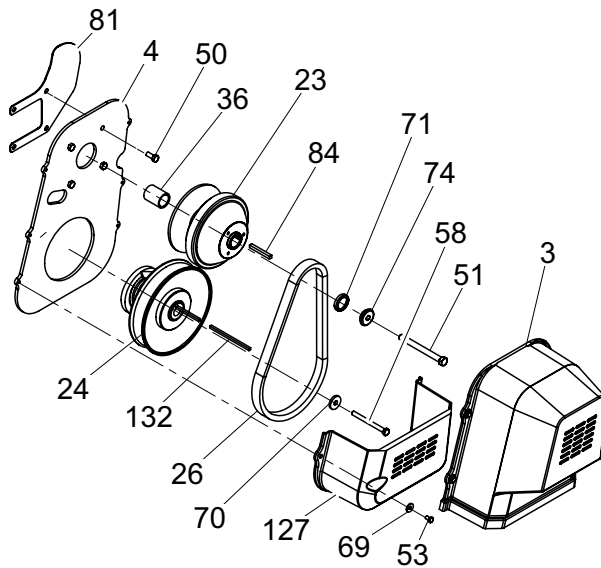

wc_gr003382

Ref.	Description	Ref.	Description
3	Upper belt guard	58	Hex head screw
4	Beltguard plate	69	Fender washer
23	Clutch	70	Washer
24	Clutch pulley	71	Washer
26	Belt	84	Key
36	Spacer	127	Lower beltguard
51	Screw	132	Key
53	Hex head Screw	-	---

6.4 Replacing the Standard Clutch

See Graphic: *wc_gr003153, wc_gr002068*

Removal:

- 6.4.1 Remove the drive belt as described in section *Replacing the Drive Belt*.
- 6.4.2 Remove the screw (51) and the washer (72) that secure the clutch assembly (23) to the crankshaft.
- 6.4.3 Loosen the setscrew(s) (2) on the clutch assembly. Pull the clutch assembly from the crankshaft. If a three-jaw puller is used, thread in the screw (51) removed in step two 4–6 turns to protect the threads in the crankshaft. Push against the bolt head rather than directly against the threads of the crankshaft.
- 6.4.4 Remove the spacer (36) and the key (84) from the crankshaft. Inspect the key and the keyways for signs of shearing. Replace the key if it is deformed or if its edges are rounded.

Installation:

- 6.4.5 Coat the engine crankshaft with an anti-seize compound and reinstall the spacer (36).
- 6.4.6 Install the key (84) in the keyway and slide the clutch assembly over the crankshaft. Tap the key with a rubber mallet if necessary. Tighten the setscrew.
- 6.4.7 Replace the washer (72) and the screw (51). Torque the screw to 25 Nm (18 ft.lbs.).
- 6.4.8 Reinstall the drive belt as described in *Replacing the Drive Belt*.

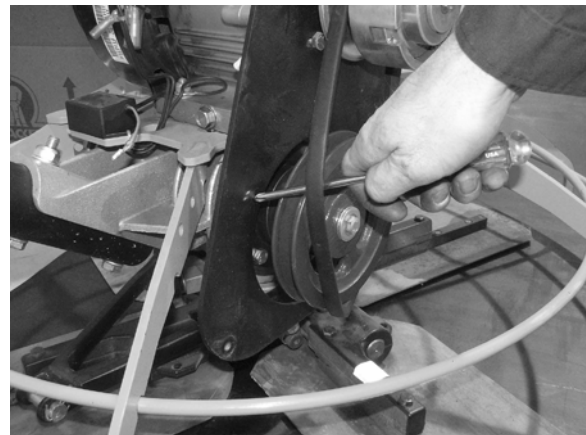
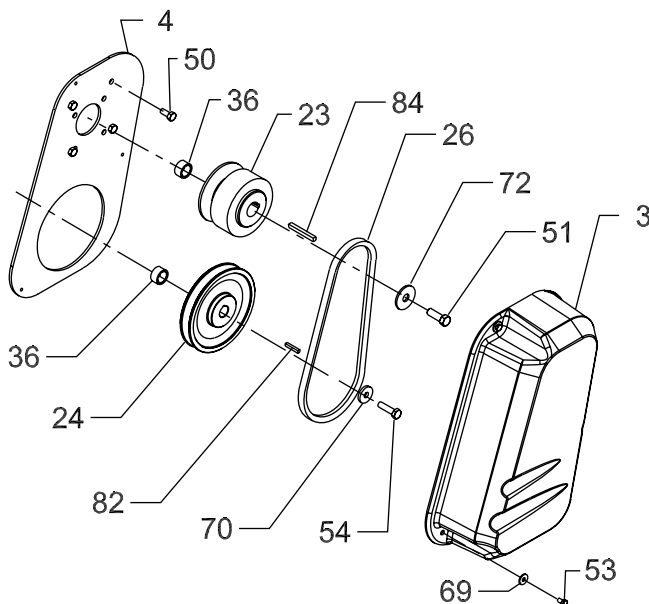

wc_gr003153

6.5 Standard Clutch—Exploded View

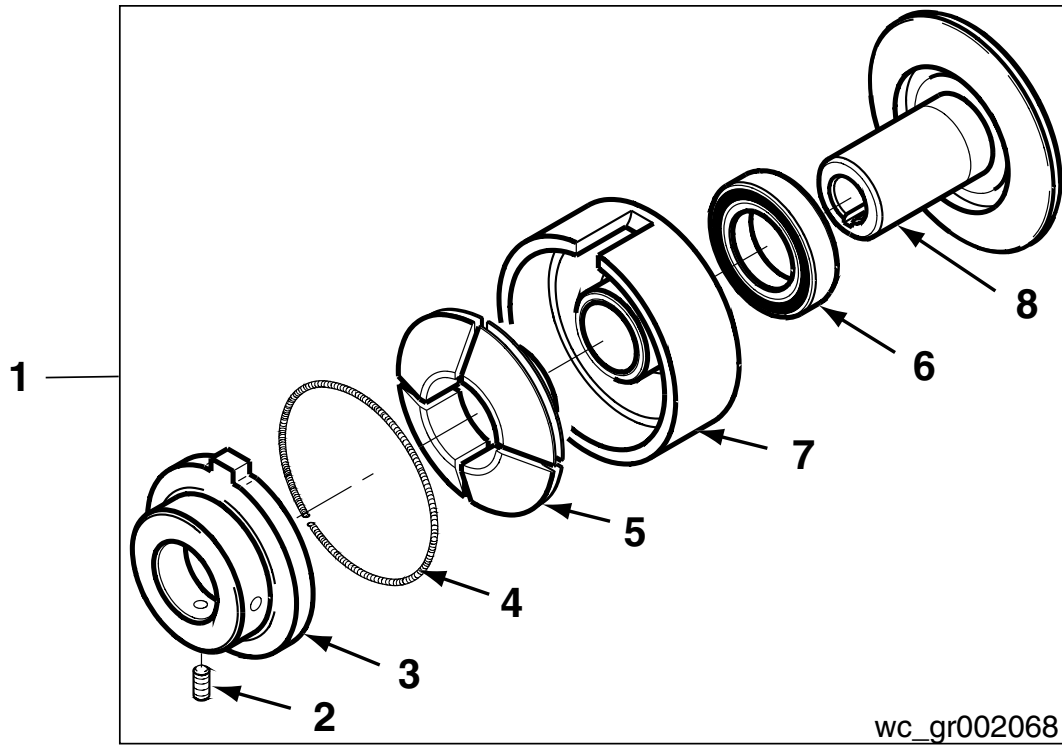

wc_gr002068

Ref.	Description	Ref.	Description
1	Clutch assembly (incl. 2–8)	5	Clutch shoe
2	Setscrew	6	Ball bearing
3	Clutch plate	7	Clutch drum
4	Spring	8	Clutch pulley

6.6 Standard Clutch Overhaul

See Graphic: *wc_gr002068* and *wc_gr003364*

This procedure requires a propane torch or similar heating device.

Disassembly:

- 6.6.1 Remove the setscrew **(2)**. Slide the clutch plate **(3)** off of the clutch pulley shaft **(8)**.
- 6.6.2 Remove and inspect the clutch shoes **(5)**, the clutch spring **(4)** and the clutch drum **(7)**. Replace any worn or damaged component.
- 6.6.3 Inspect the bearing **(6)** for free rotation on the shaft. Replace the bearing if necessary. To remove the bearing, heat it with a propane torch. Then, while protecting your hands from any hot surface, pick up the clutch pulley-bearing assembly **(a)** and strike it against a wooden (or similar) surface **(b)**. The force of the blow should free the bearing. Use a puller to remove the bearing the rest of the way if necessary.

Assembly:

NOTICE: Do not grease or oil the clutch pulley shaft or the clutch drum.

- 6.6.4 Press the bearing **(6)** onto the clutch pulley shaft **(8)**.
- 6.6.5 Slide the clutch drum over the clutch pulley shaft.
- 6.6.6 Band the clutch shoes **(5)** with the clutch spring. Then, slide the clutch shoes over the clutch pulley shaft. The clutch shoes should move freely over the clutch pulley shaft.
- 6.6.7 Slide the clutch plate **(3)** over the clutch pulley shaft and tighten the setscrew **(2)**.

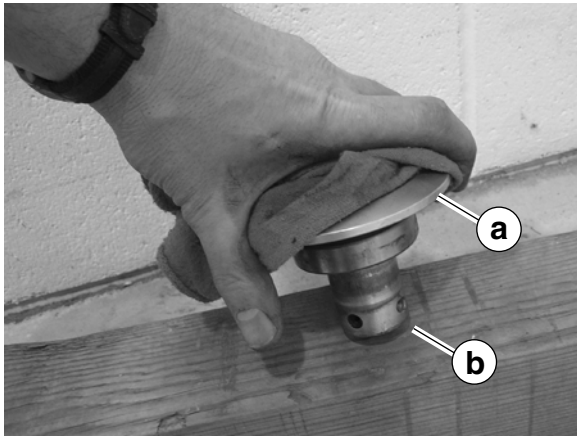
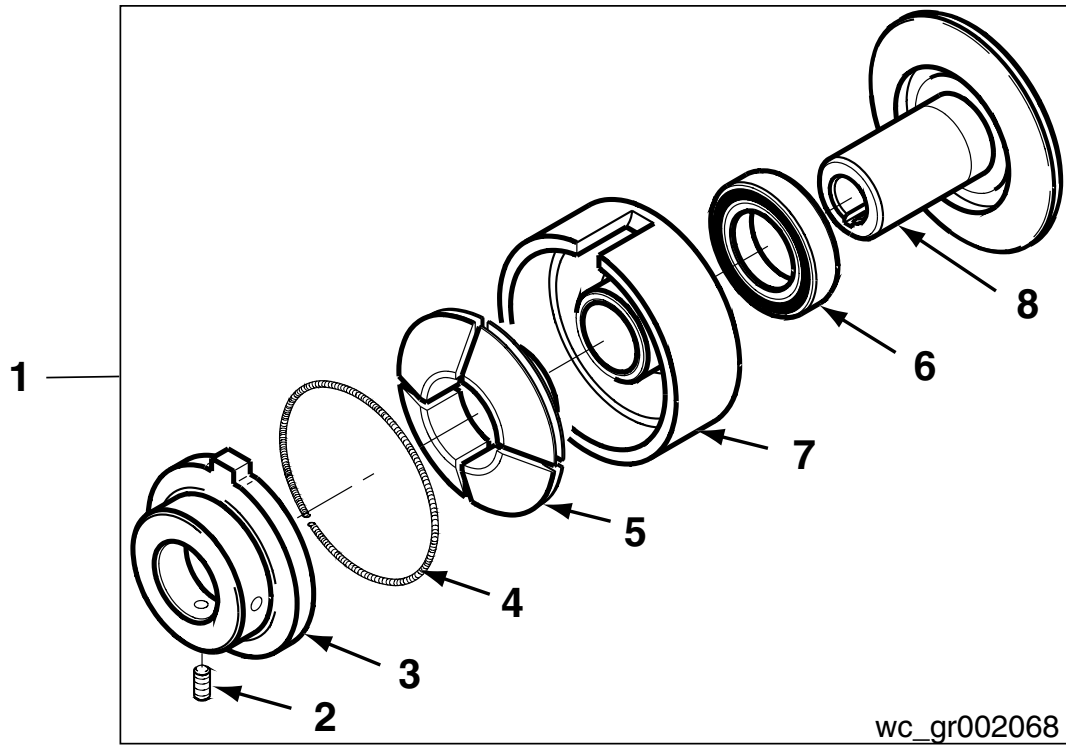

wc_gr003364

6.7 Replacing the Variable Speed Clutch

See Graphic: *wc_gr003383, wc_gr002068*

Removal:

- 6.7.1 Remove the drive belt. See section *Replacing the Drive Belt*.
- 6.7.2 Remove the bolt **(51)** that secures the clutch **(23)** to the engine drive shaft and slide the clutch from the engine drive shaft. **Note:** *Use a gear puller if necessary.*
- 6.7.3 Remove the key **(84)**.
- 6.7.4 Remove the bolt **(58)** that secures the clutch pulley **(24)** to the gearbox input shaft and remove the clutch pulley.
- 6.7.5 Remove the key **(132)**.

Installation:

- 6.7.6 Install the key **(132)** onto the gearbox input shaft.
- 6.7.7 Slide the clutch pulley **(24)** over the gearbox input shaft.
- 6.7.8 Apply Loctite 243 or equivalent to the bolt **(58)** and secure the clutch pulley to the gearbox input shaft.
- 6.7.9 Install the key **(84)** onto the engine drive shaft.
- 6.7.10 Slide the clutch **(23)** over the engine drive shaft.
- 6.7.11 Apply Loctite 243 or equivalent to the bolt **(51)** and secure the clutch to the engine drive shaft.

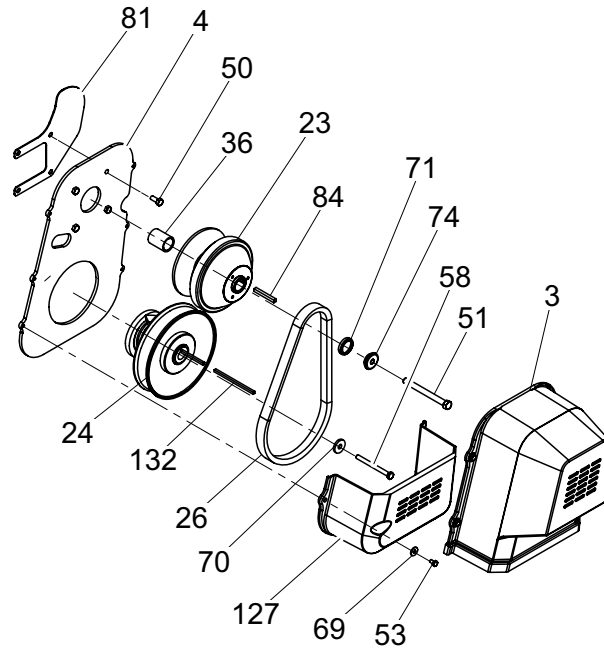

wc_gr003383

7. Spider

7.1 Spider Assembly—Exploded View

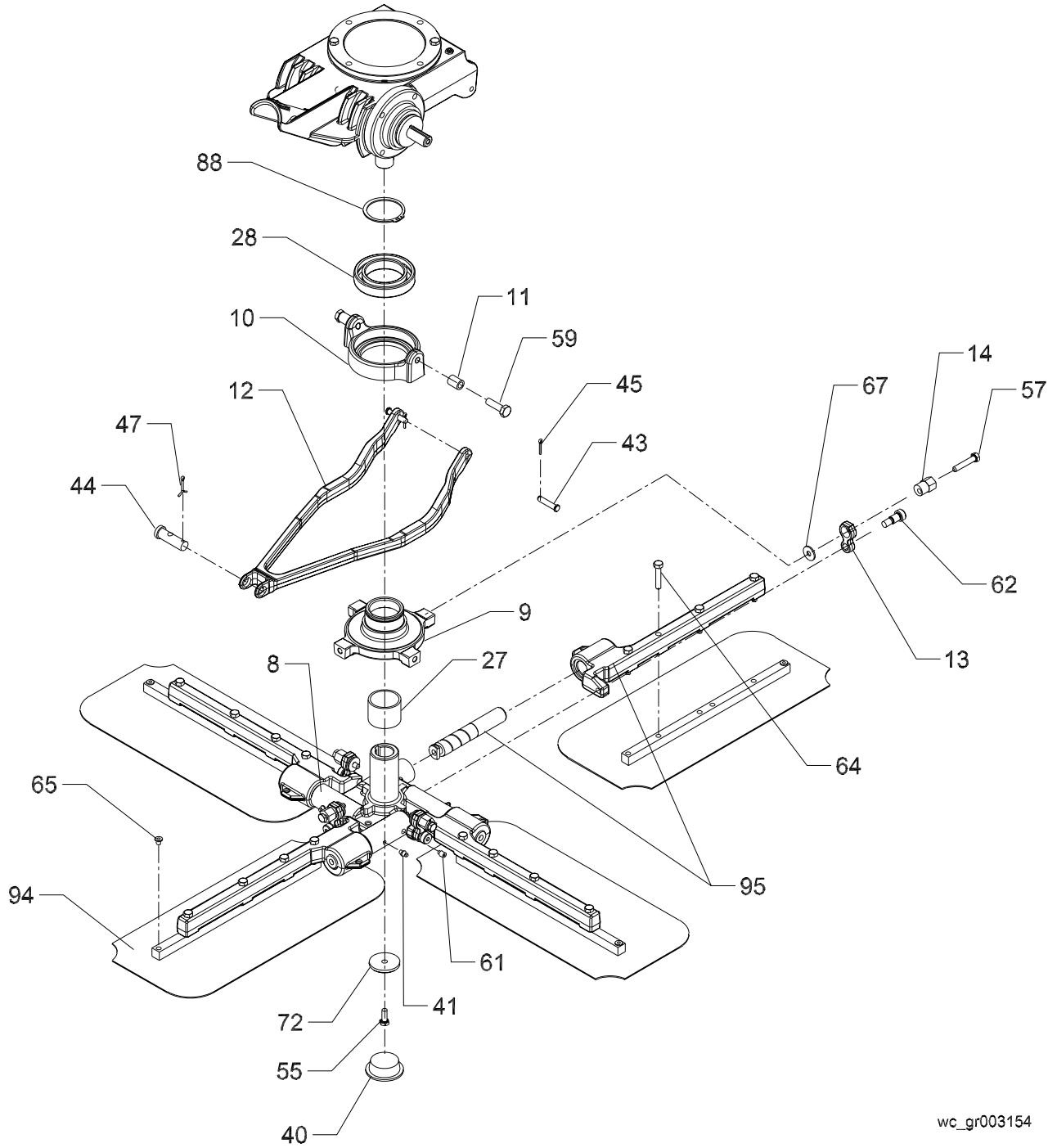

wc_gr003154

7.2 Spider Assembly—Components

Ref.	Description	Ref.	Description
8	Spider	47	Cotter pin
9	Blade lift ring	55	Hex head screw
10	Bearing holder	57	Hex head screw
11	Tube	59	Lifting bolt
12	Yoke	61	Setscrew
13	Link	62	Screw
14	Eccentric adjuster	64	Screw
27	Bearing sleeve	65	Plug (threaded)
28	Ball bearing	67	Fender washer
40	Cap plug	72	Washer
41	Grease fitting	88	Retaining ring
43	Clevis pin	94	Set-combo blade
44	Grease fitting	95	Blade arm assembly
45	Cotter pin		

7.3 Replacing the Blades

See Graphic: *wc_gr003365*

If any blade requires replacement, replace all the blades.



WARNING

The blades can become extremely sharp. Use great care when replacing the blades.



WARNING

Disconnect or remove the spark plug to avoid accidentally starting the engine when turning the trowel blades.

- 7.3.1 Pitch the blades so that they lie flat.
- 7.3.2 Remove the screws **(a)** that secure the blade **(b)** to the blade arm and remove the blade. Do so for all blades.
- 7.3.3 Check each arm for straightness. Replace any arm that is not straight. See section *Replacing the Arms*.
- 7.3.4 Use Loctite 243 or equivalent on the screws and secure the blades to the arms.
- 7.3.5 Balance the blades. See section *Balancing the Blade Pitch*.

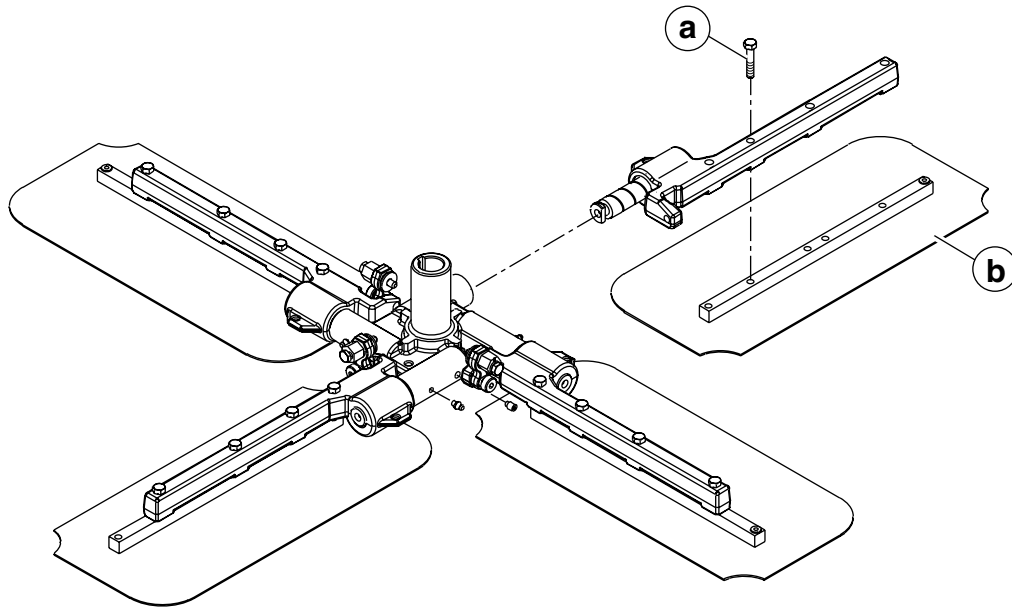

wc_gr003365

7.4 Replacing the Arms

See Graphic: *wc_gr003356*



WARNING

The blades can become extremely sharp. Use great care when replacing the blades.



WARNING

Disconnect or remove the spark plug to avoid accidentally starting the engine when turning the trowel blades.

Removal:

- 7.4.1 Remove the blades. See section *Replacing the Blades*.
- 7.4.2 Remove the arm retaining screw **(a)** and the eccentric adjuster **(b)** (or just the shoulder bolt **(c)**) from the spider **(d)**.
- 7.4.3 Rotate the arm assembly 180° and slide the arm assembly **(e)** from the spider.
- 7.4.4 Inspect the condition of the grease fitting **(f)** and the setscrew **(g)** of the spider. Replace these components as necessary. When replacing the setscrew, leave one thread extending outside of the spider.
- 7.4.5 Inspect the arm for straightness.
 - Use the flattest and smoothest surface available and two spacers **(h)** of equal size. Place the spacers on the surface. Set the arm on the spacers so that the two machined surfaces of the arm ride on the spacers. Measure the distance between the surface and the pin of the arm in several locations. The measurements **(x)** should all be equal.
 - If the difference between any of the measurements is more than 1.5 mm (0.062 in.), the arm is not straight; replace it.

Installation:

- 7.4.6 Coat the arm assembly **(e)** with a thin film of grease and slide it into the spider. Slide the flat **(i)** of the arm past the setscrew **(g)** of the spider and then rotate the arm 180°.
- 7.4.7 Install the arm retaining screw **(a)** and the eccentric adjuster **(b)** to the spider **(d)**. Torque the retaining screw to 41 Nm (30 ft.lbs.).
- 7.4.8 Install the blades. See section *Replacing the Blades*.

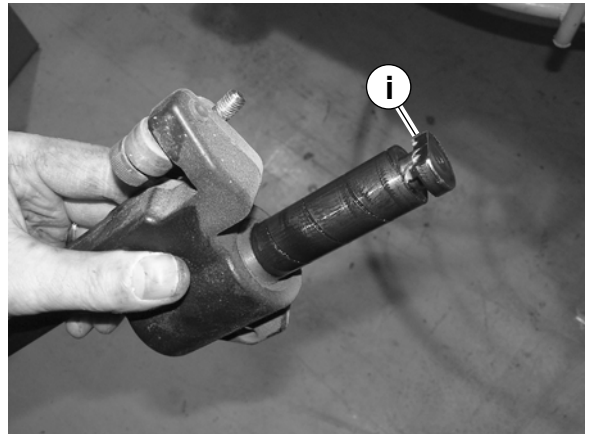
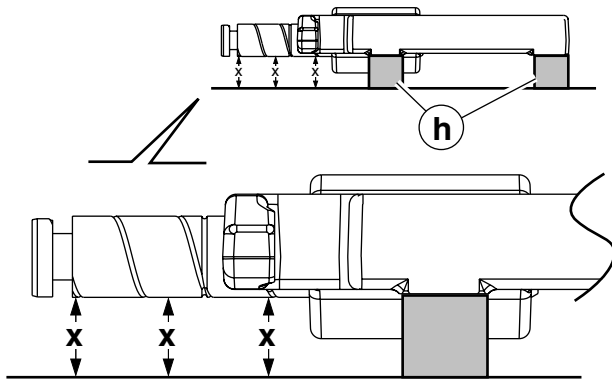
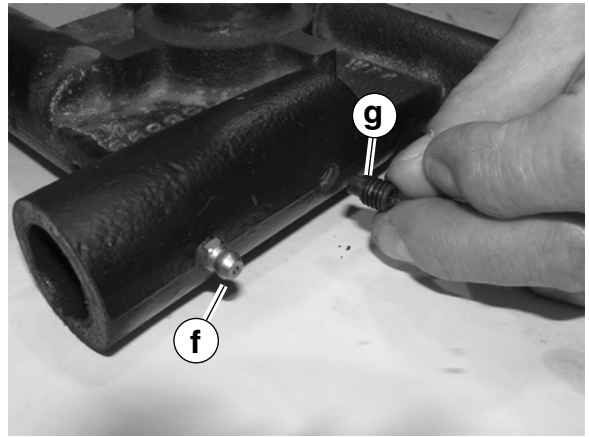
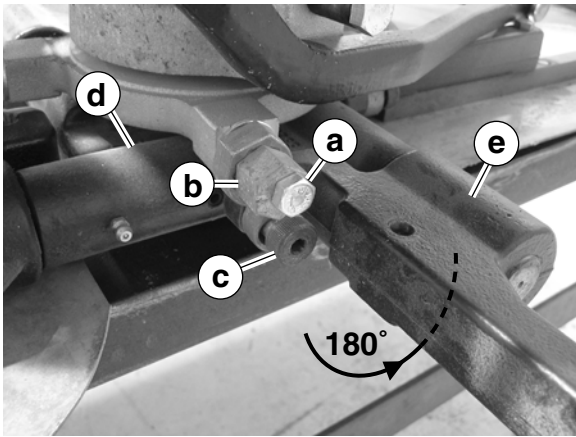

wc_gr003356

7.5 Balancing the Blade Pitch

See Graphic: *wc_gr003357*

To prevent wobble and for optimum performance balance the blade pitch. Carry out the following procedures whenever the blades or any of the arms have been replaced, or if the trowel is not performing as it should.

To balance the blade pitch:

- 7.5.1 Place the trowel on a flat surface.
- 7.5.2 Adjust the pitch control (Pro-Shift[®] or twist pitch control) so that all the blades lie flat (0° pitch).
- 7.5.3 Mark on the floor the outline (**a**) of two blades that are 180° apart from each other. Label one of these blades "1". Continue to label the remaining blades in order: "2", "3", and "4".
- 7.5.4 Adjust the pitch control (Pro-Shift[®] or twist pitch control) so that all the blades pitch approximately 15°.
- 7.5.5 Position the handle directly above the blade labeled "1".
- 7.5.6 Measure the distance (**x**) from the handle (at the stop switch (**b**)) to the floor.
- 7.5.7 Rotate the entire trowel 90° counterclockwise. The brake will engage and the blades will slide across the floor. Position the blade labeled "2" in the outline on the floor of the blade labeled "1".
- 7.5.8 Rotate the handle clockwise (it will rotate freely) and position it directly above the blade labeled "2".
- 7.5.9 Measure the distance (**x**) from the handle (at the stop switch) to the floor.
- 7.5.10 Repeat the procedure for each blade.
- 7.5.11 Use the eccentric adjuster (**c**) on each arm to adjust the distance between the handle and the floor. Tighten the mounting screw (**d**) after making the adjustments. For consistency, only make adjustments when the blade being adjusted is within the outline of the blade labeled "1" and measure to the same spot on the floor each time.
- 7.5.12 Make any adjustments required until the distance between the floor and the handle is within 1.5 mm (0.062 in.) for all of the blades.

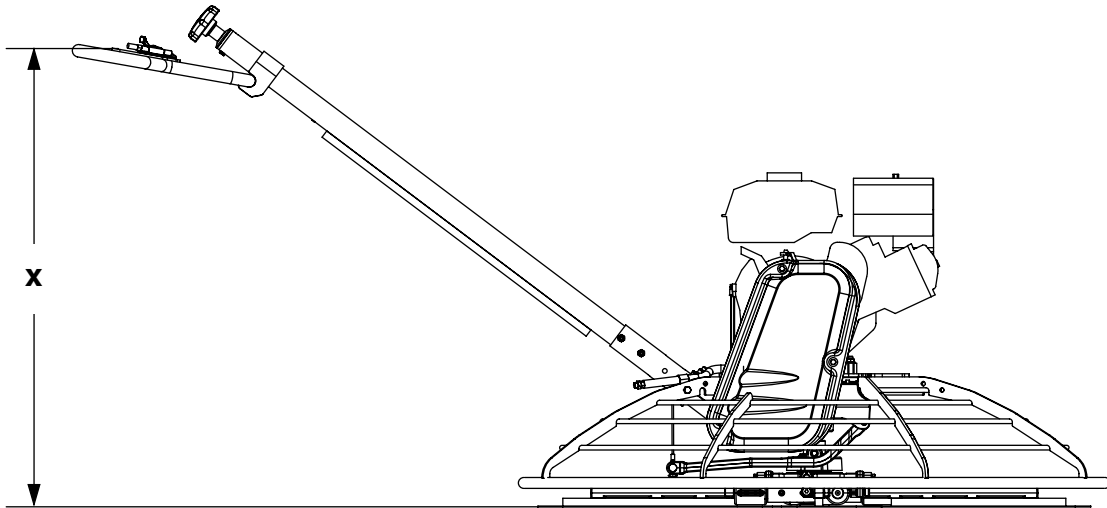
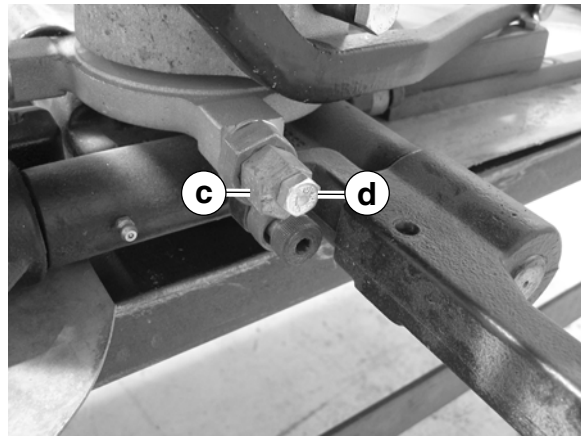
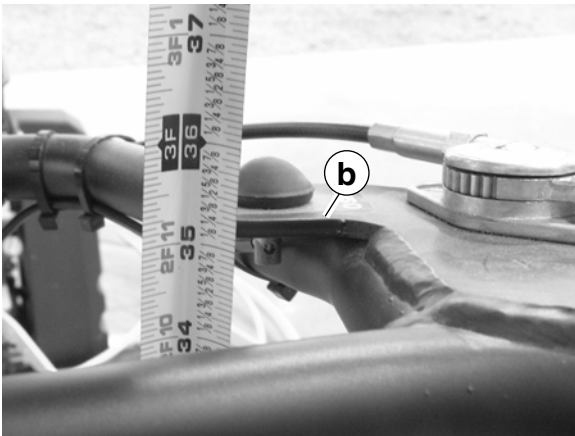
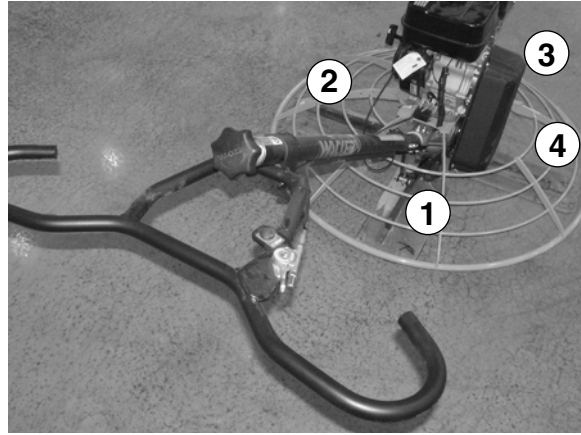
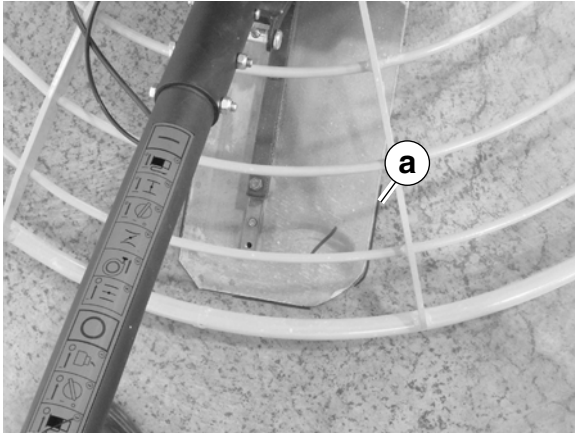

wc_gr003357

7.6 Removing the Spider

See Graphic: *wc_gr003154*



WARNING

Disconnect or remove the spark plug to avoid accidentally starting the engine when turning the trowel blades. See section *Engine Wiring*.

This procedure requires an appropriate hoist or crane to lift the trowel.

- 7.6.1 Pitch the blades so they lie flat (0° pitch).
- 7.6.2 Remove the lock nut from the bottom of the pitch control cable. Disengage the pitch control cable from the yoke.
- 7.6.3 Remove the clevis pin **(43)** and the cotter pin **(45)** to release the yoke **(12)** from the gearbox. Slide the yoke free of the guard ring.
- 7.6.4 Lift the trowel by the lifting eye to gain access to the underside of the spider.



WARNING

The trowel arms are free to rotate. Be careful when handling the trowel to avoid pinching your hands or fingers between the trowel blades.

- 7.6.5 Remove the arms from the spider. See section *Replacing the Arms*.
- 7.6.6 Remove the cap plug **(40)** from the bottom of the spider.
- 7.6.7 Carefully hold the trowel arms in a stationary position. Remove the screw **(55)** and the washer **(72)** that secure the spider to the output shaft. Pull the spider assembly from the output shaft.
- 7.6.8 Remove the blade lift ring assembly **(9, 10, 28, 88)** from the spider **(8)**.

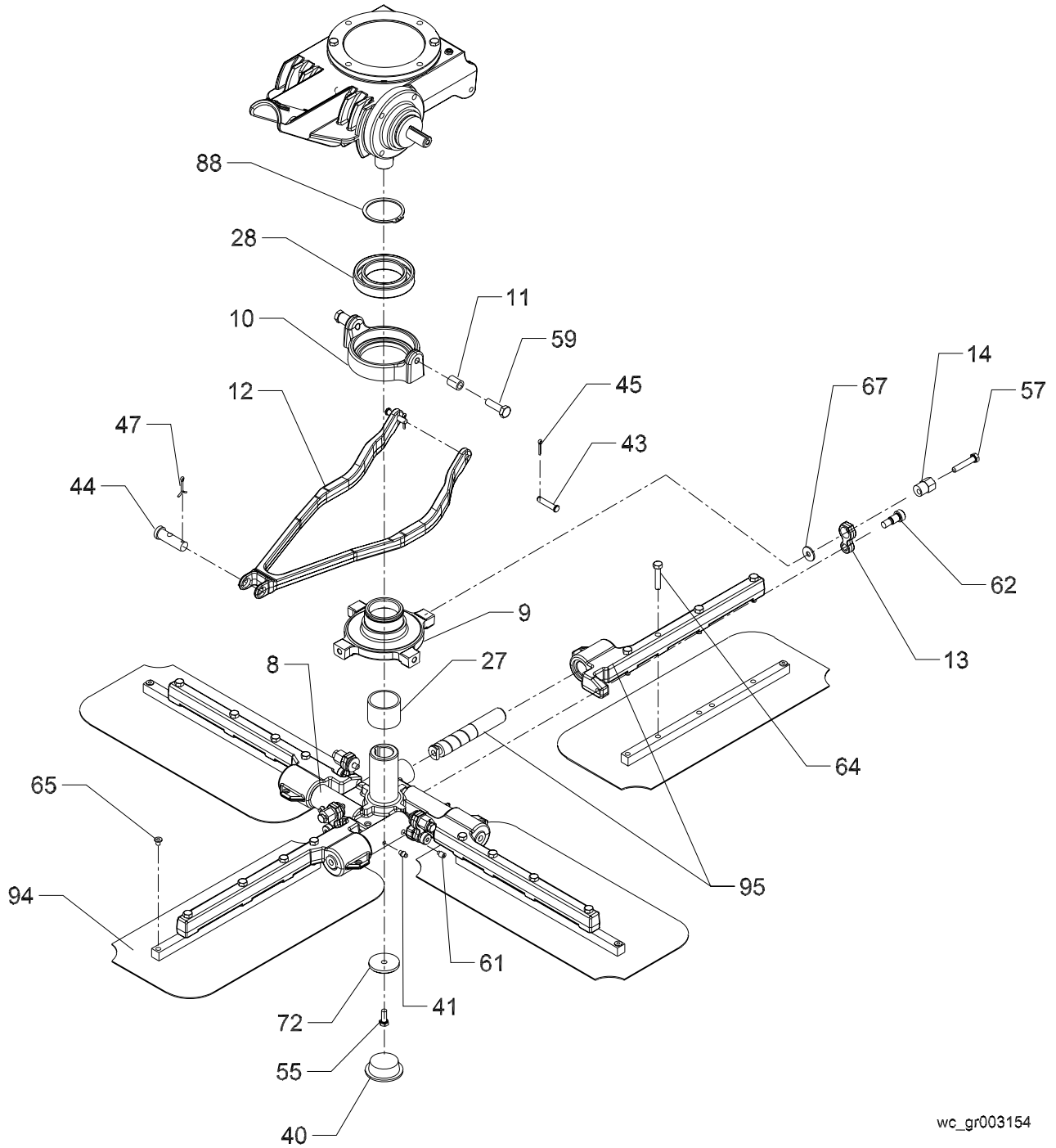

wc_gr003154

7.7 Installing the Spider

See Graphic: *wc_gr003154*

- 7.7.1 Install the setscrews **(61)** into the spider so that all but one thread is threaded into the spider.
- 7.7.2 Apply Alvania #2 or equivalent to the grease fittings **(41)** and install them into the spider.
- 7.7.3 Coat the bearing sleeve of the blade lift ring assembly **(9, 10, 28, 88)** with anti-seize compound and slide the blade lift ring assembly over the spider **(8)**.
- 7.7.4 Slide the spider assembly onto the output shaft. Check for free movement of the blade lift ring over the spider.
- 7.7.5 Apply Loctite 243 or equivalent to the screw **(55)**; use the screw and the washer **(72)** to secure the spider to the output shaft. Torque the screw to 25 Nm (18 ft.lbs.).
- 7.7.6 Install the cap plug **(40)**.
- 7.7.7 Slide the yoke **(12)** around the blade lift ring. Attach the yoke to the gear box with the clevis **(43)** and the cotter pin **(45)**.
- 7.7.8 Reinstall the blade arms and the blades. See sections *Replacing the Blades* and *Replacing the Arms*.
- 7.7.9 Reposition the trowel on a flat surface.
- 7.7.10 Thread the pitch control cable into the yoke and attach the locknut. Tighten the locknut until the cable is snug with the blades lying flat (0° pitch).
- 7.7.11 Balance the blades. See section *Balancing the Blade Pitch*.

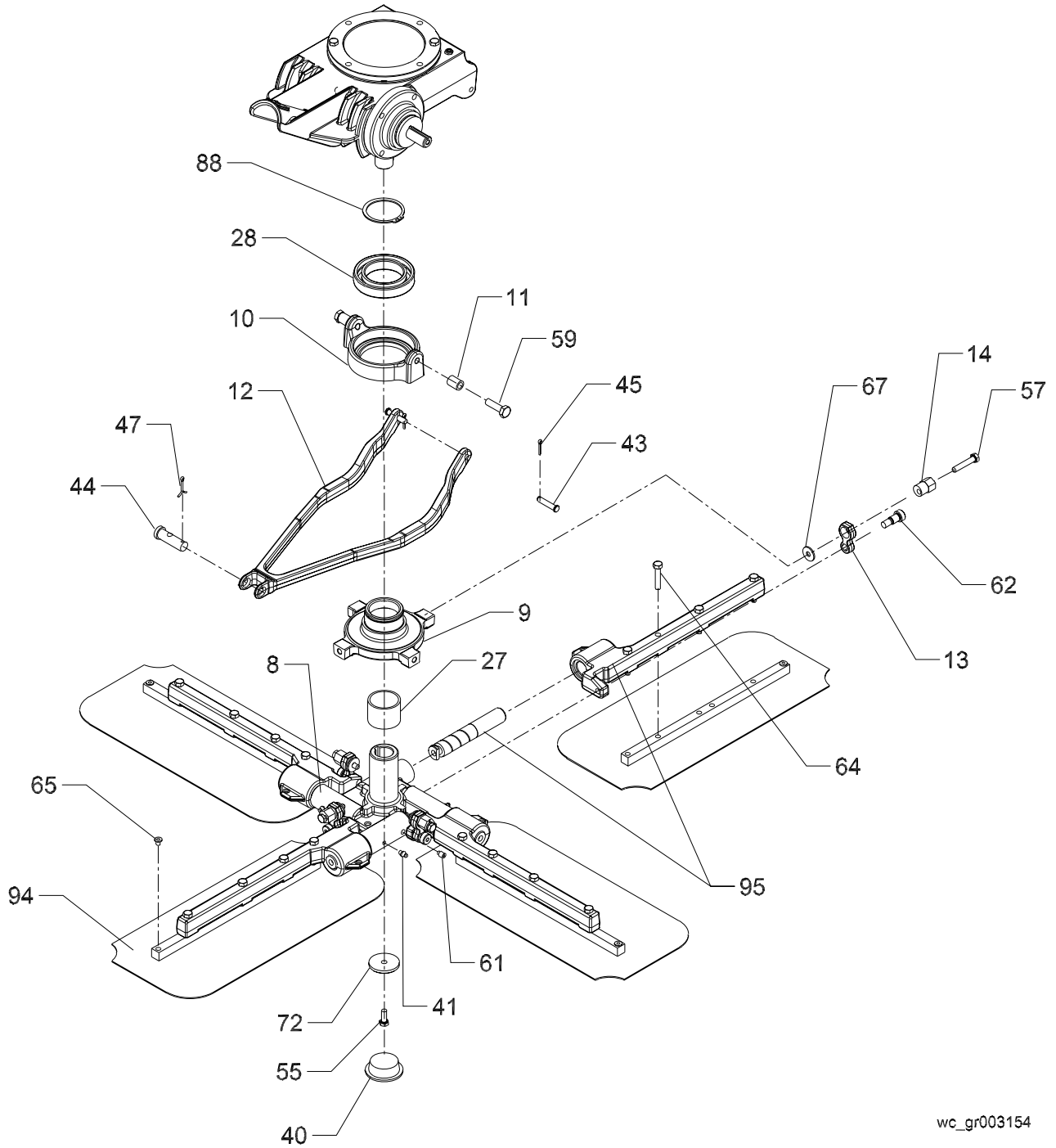

wc_gr003154

7.8 Rebuilding the Lift Ring Assembly

See Graphic: *wc_gr003358*

Inspect the lift ring assembly for wear or damage. Replace any damaged or worn component.

This procedure requires an Arbor or similar press.

Disassembly:

- 7.8.1 Remove the retaining ring **(88)**.
- 7.8.2 Press the bearing holder **(10)** from the blade lift ring **(9)**.
- 7.8.3 Press the ball bearing **(28)** from the bearing holder.
- 7.8.4 Press the bearing sleeve **(27)** from the blade lift ring.
- 7.8.5 If you are replacing the lifting bolts **(59)** and/or the tube **(11)**, to assist in their removal, heat the lifting bolt to breakdown the thread locking compound that secures it to the bearing holder **(9)**.

Assembly:

- 7.8.6 Lubricate the bearing sleeve **(27)** with a thin film of grease and press it into the blade lift ring **(9)**.
- 7.8.7 Lubricate the ball bearing **(28)** with a thin film of grease and press it into the bearing holder **(10)**.
- 7.8.8 If the lifting bolts **(59)** and/or the tube **(11)** were removed from the bearing holder, apply Loctite 271 or equivalent to the lifting bolts. Then, slide the tube over the lifting bolt, and attach the lifting bolt to the blade lift ring. Tighten the lifting bolt until the tube does not rotate, then back off the lifting bolt just until the tube can rotate. Do not use the trowel until the Loctite 271 has fully cured; approximately 12 hours.
- 7.8.9 Position the bearing holder over the blade lift ring and secure them together with the retaining ring **(88)**.

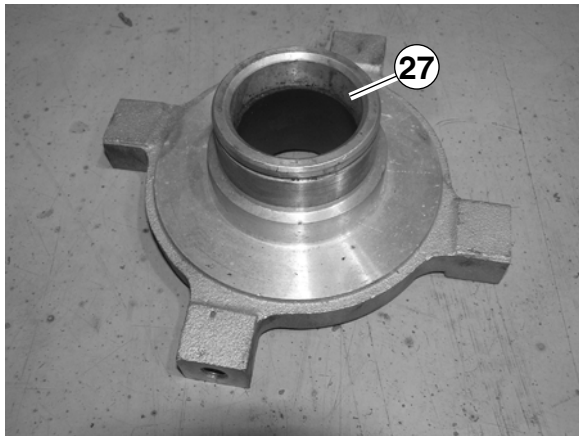
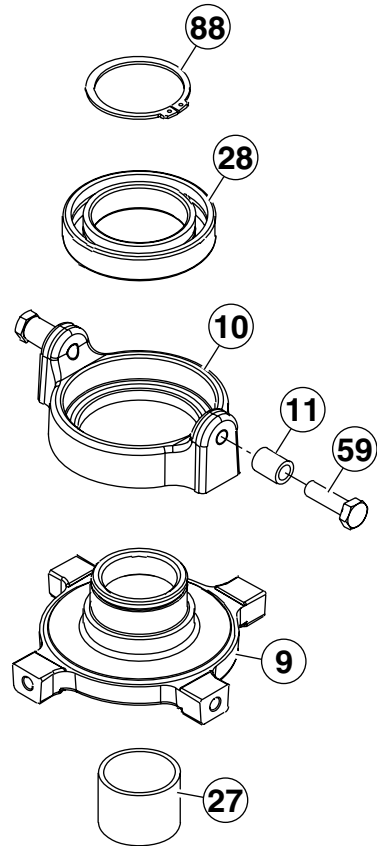
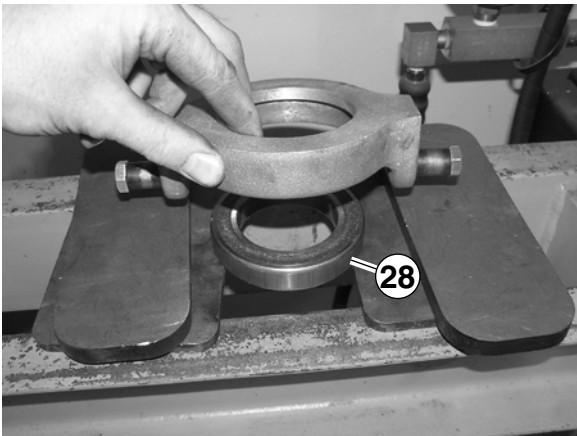
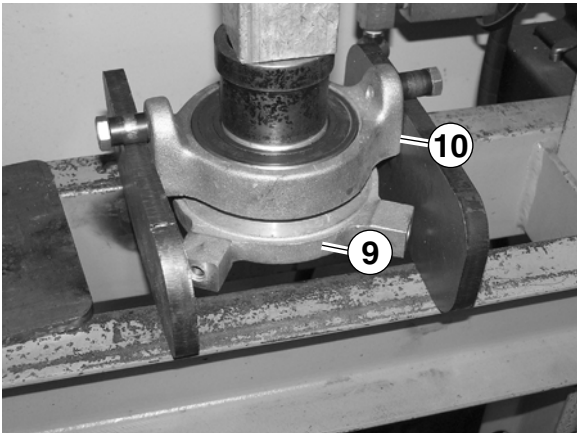

wc_gr003358

8. Drivetrain

8.1 Drivetrain—Exploded View

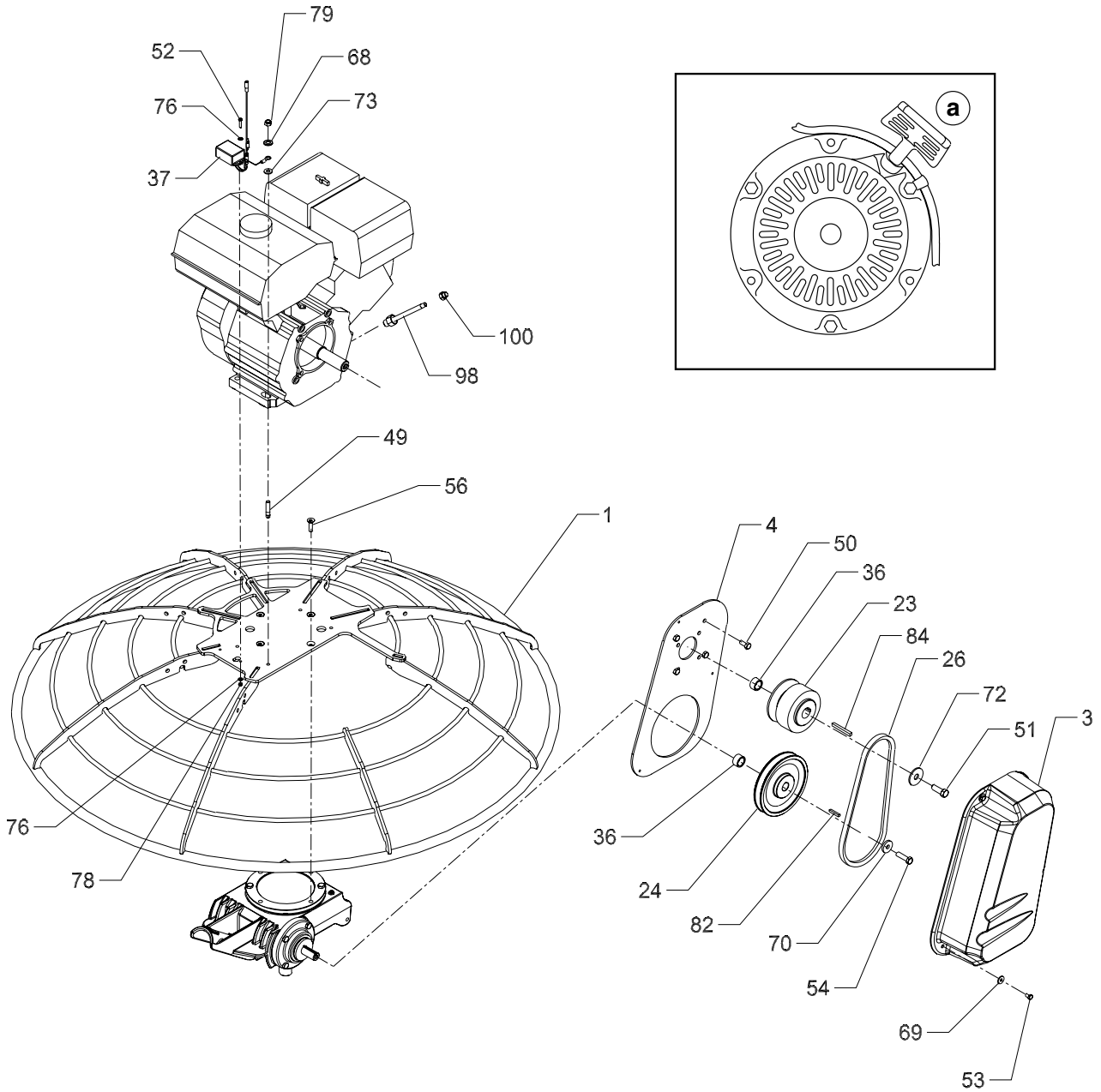

wc_gr003155

8.2 Drivetrain—Components

Ref.	Description	Ref.	Description
1	Guard ring	68	Lockwasher
4	Beltguard plate	73	Flat washer
36	Spacer	76	Flat washer
37	Engine control module (gyro switch)	78	Locknut
49	Stud	79	Locknut
50	Screw	98	Oil drain fitting
52	Pan head screw	100	Pipe cap
56	Flat head screw		

8.3 Engine Removal

See Graphic: *wc_gr003155*

- 8.3.1 To gain access to the throttle cable at the engine, remove the air cleaner. Then, disconnect the throttle cable from the engine throttle bracket. See section *Replacing the Throttle Cable*.
- 8.3.2 Cut the tie-wraps holding the harness to the engine and remove the harness. Disconnect the wiring from the engine to the stop switch and from the engine to the engine control module (gyro switch). See section *Engine Wiring*.
- 8.3.3 Remove the drive belt as described in section *Replacing the Drive Belt*.
- 8.3.4 Remove the clutch assembly as described in section *Replacing the Standard Clutch*.
- 8.3.5 Slide the spacer **(36)** from the engine drive shaft.
- 8.3.6 Remove the screws **(50)** from the beltguard plate **(4)** and remove the beltguard plate.
- 8.3.7 Remove the washers **(68)** and the locknuts **(79)**.
- 8.3.8 Remove the washer **(73)** and the ring terminal **(37)** of the engine control module (gyro switch) from the engine stud.
- 8.3.9 Slide the engine off of the guard ring **(1)**.
- 8.3.10 For the engine overhaul procedures, refer to the engine manufacturer's repair manual.

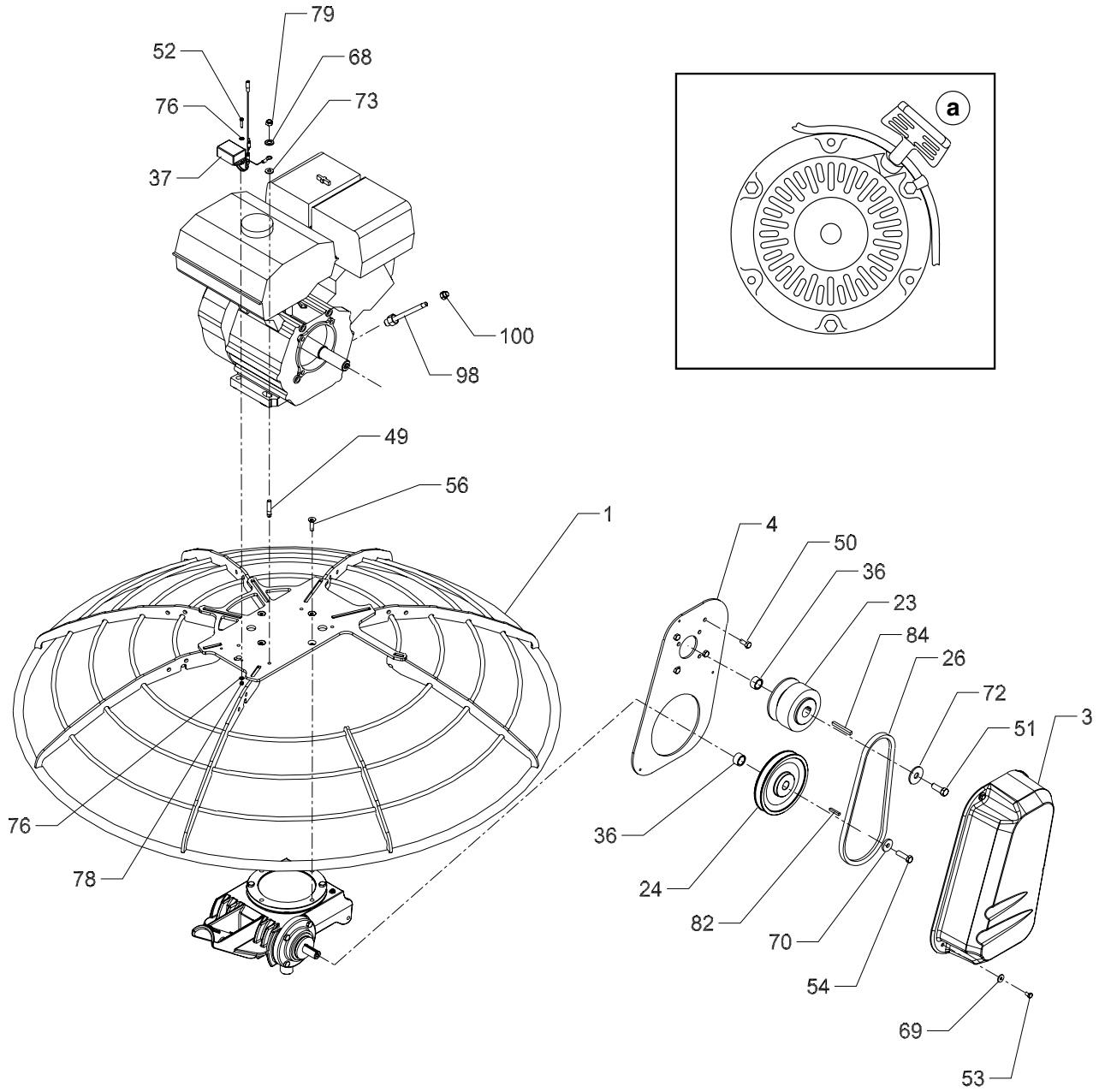

wc_gr003155

8.4 Engine Installation

See Graphic: *wc_gr003155*

- 8.4.1 Align the engine with the engine studs on the guard ring. Place the washer **(73)** and the ring terminal of the engine control module (gyro switch) **(37)** over the engine stud. Place the washers **(68)** over all the studs and secure the engine with the locknuts **(79)**. Torque the locknuts to 25 Nm (18 in.lbs.).
- 8.4.2 Fasten the beltguard plate **(4)** to the engine with screws **(50)**. Torque the screws to 25 Nm (18 ft.lbs.).
- 8.4.3 If the oil drain fitting **(98)** was removed, apply pipe thread sealant to the oil drain fitting and attach it to the engine. Torque the drain fitting from 16–20 Nm (12–14 ft.lbs.). Fasten the pipe cap **(100)** to the open end of the oil drain fitting **(98)**. Torque the pipe cap from 16–20 Nm (12–14 ft.lbs.).
- 8.4.4 Apply anti-seize to the engine drive shaft and slide on the spacer **(36)**.
- 8.4.5 Reinstall the clutch assembly as described in section *Replacing the Clutch*.
- 8.4.6 Reinstall the drive belt as described in section *Replacing the Drive Belt*.
- 8.4.7 Loosen the screws holding the recoil cover. Rotate the cover so the base of the starter rope is at the two o'clock position **(a)**. Refasten the clamp if it was removed. Tighten the screws to secure the cover.
- 8.4.8 Attach the engine wires to the engine. See section *Engine Wiring*.
Note: *On the Wacker engines do not connect the wires in the bag to the wires of the handle.*
- 8.4.9 Wrap the harness material around the engine wires and secure with cable ties. Replace the cable tie holding the harness to the engine.
- 8.4.10 Connect the handle stop switch wires to the engine. See section *Engine Wiring*.
- 8.4.11 Reconnect the throttle cable to the engine's throttle bracket. See section *Replacing the Throttle Cable*. Adjust the throttle cable as described in section *Adjusting the Throttle Lever*.
- 8.4.12 Replace the air filter.

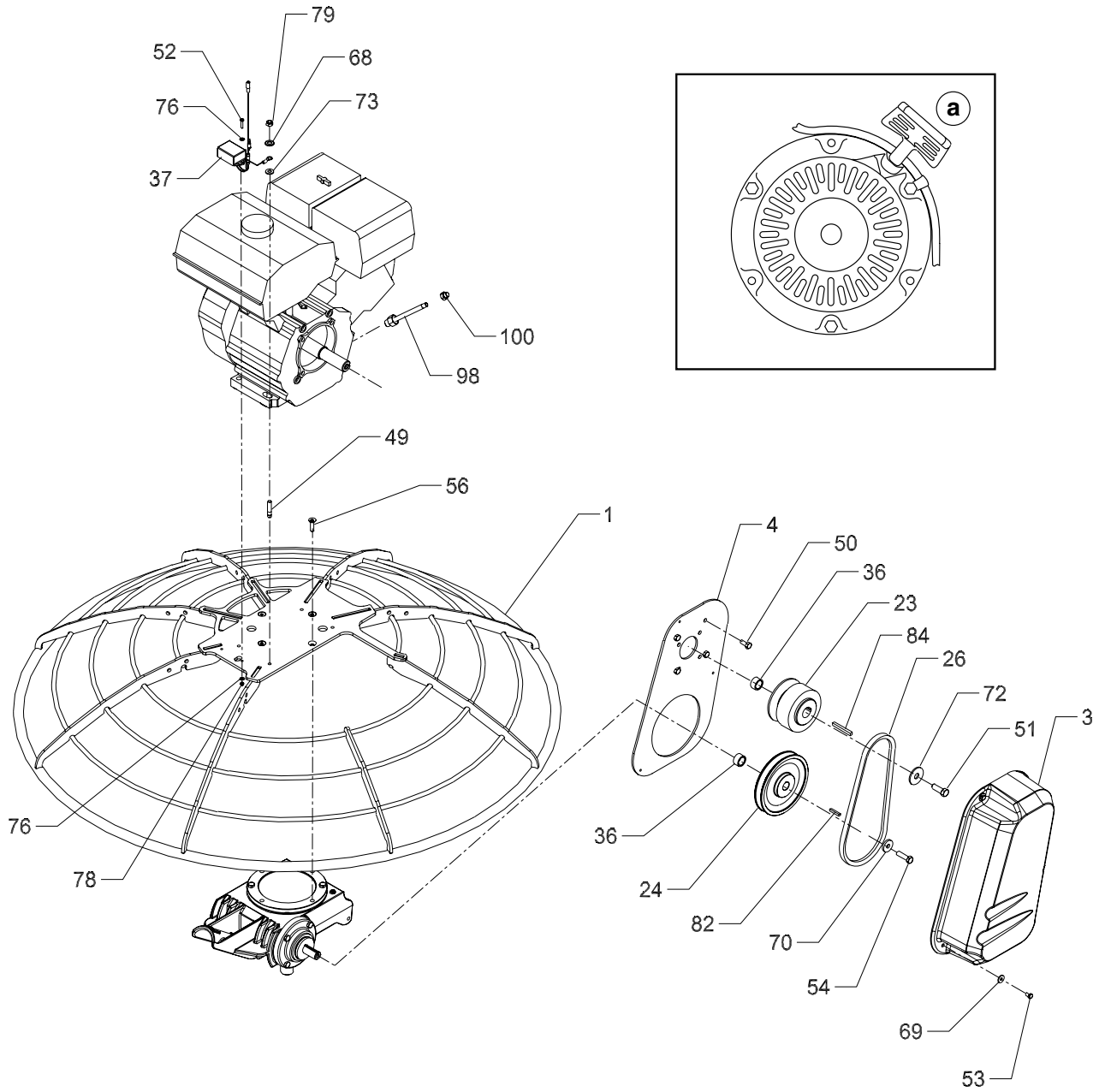

wc_gr003155

8.5 Engine Wiring

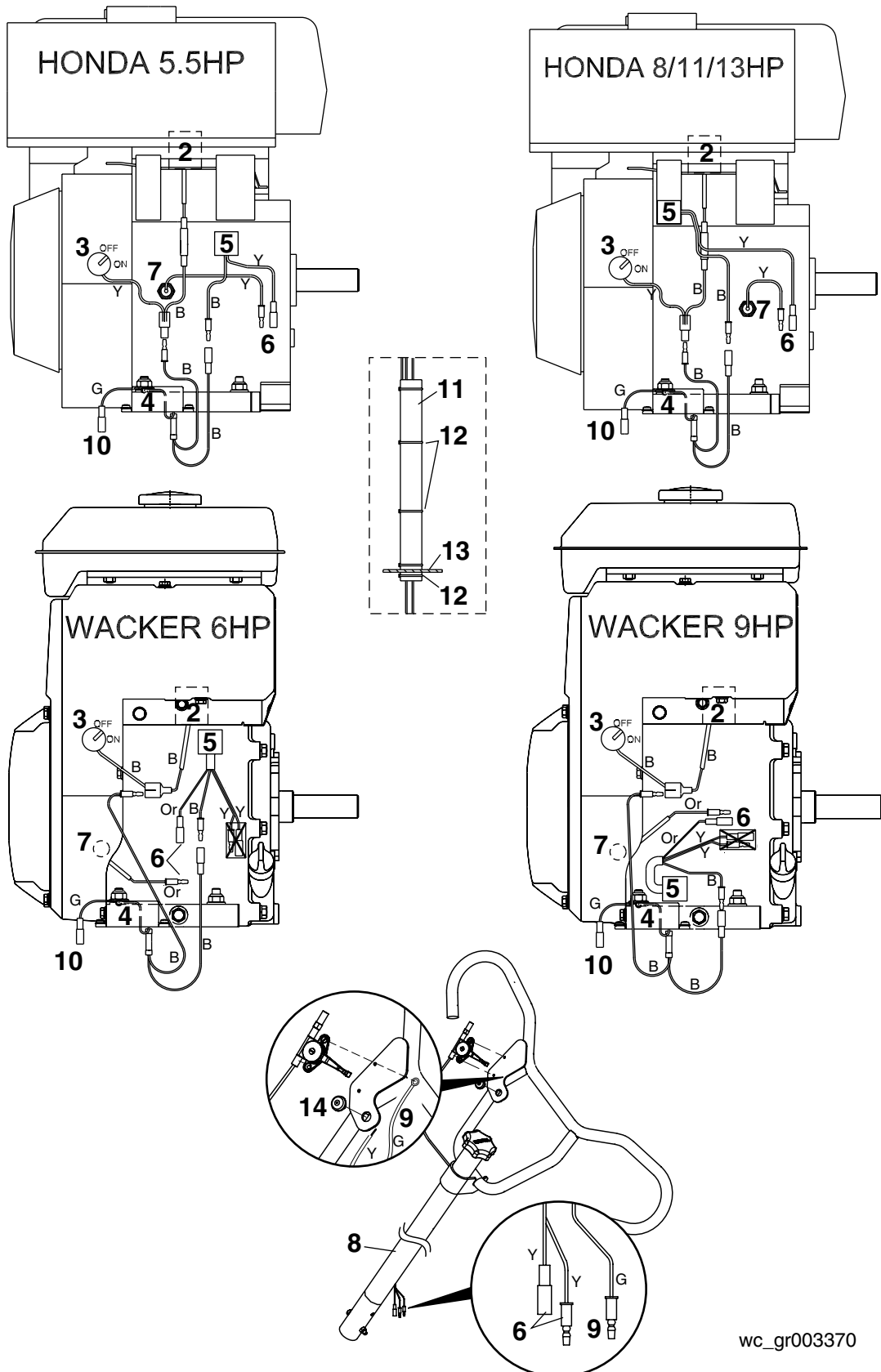

wc_gr003370

8.6 Engine Wiring Components

See Graphic: *wc_gr003369* and *wc_gr003370*

Ref.	Description	Ref.	Description
1	Spark plug	8	Handle
2	Ignition module	9	Handle ground wire*
3	Engine ON/OFF switch	10	Engine ground wire*
4	Engine control module	11	Harness (loom)
5	Oil alert unit	12	Cable tie
6	To stop switch	13	Engine mount plate
7	Low oil switch	14	Stop switch

* Used on newer machines. On older machines, the handle serves as the connection to ground.

8.7 Wiring Diagrams

Wacker

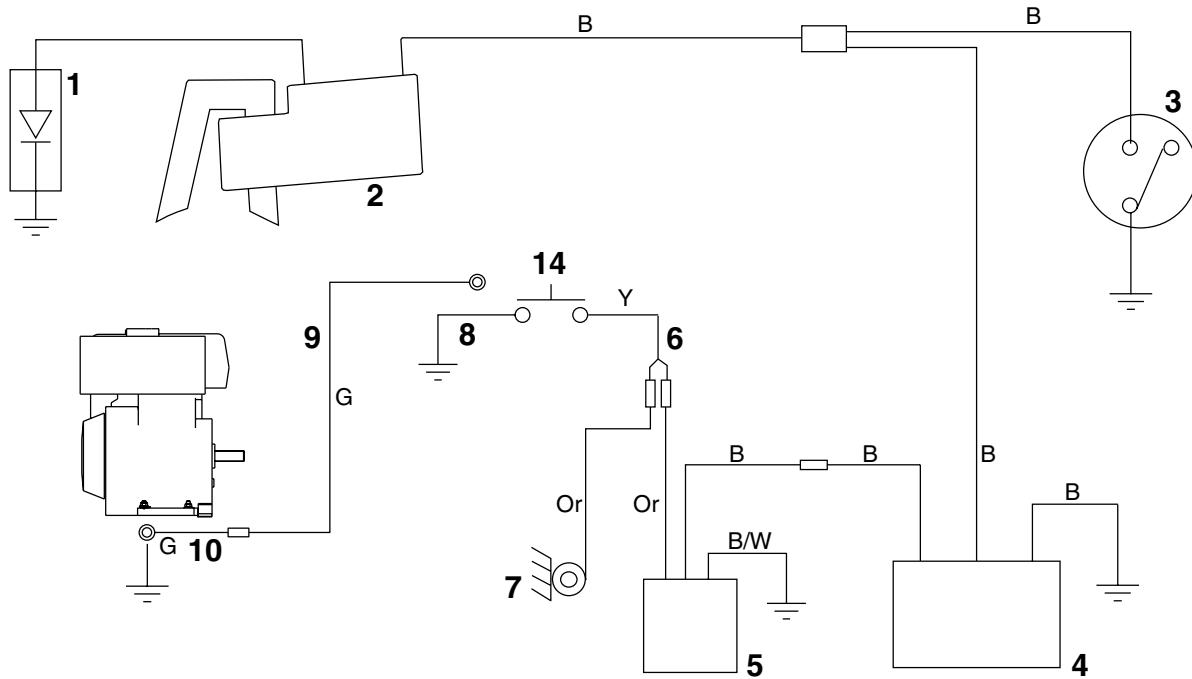

Honda

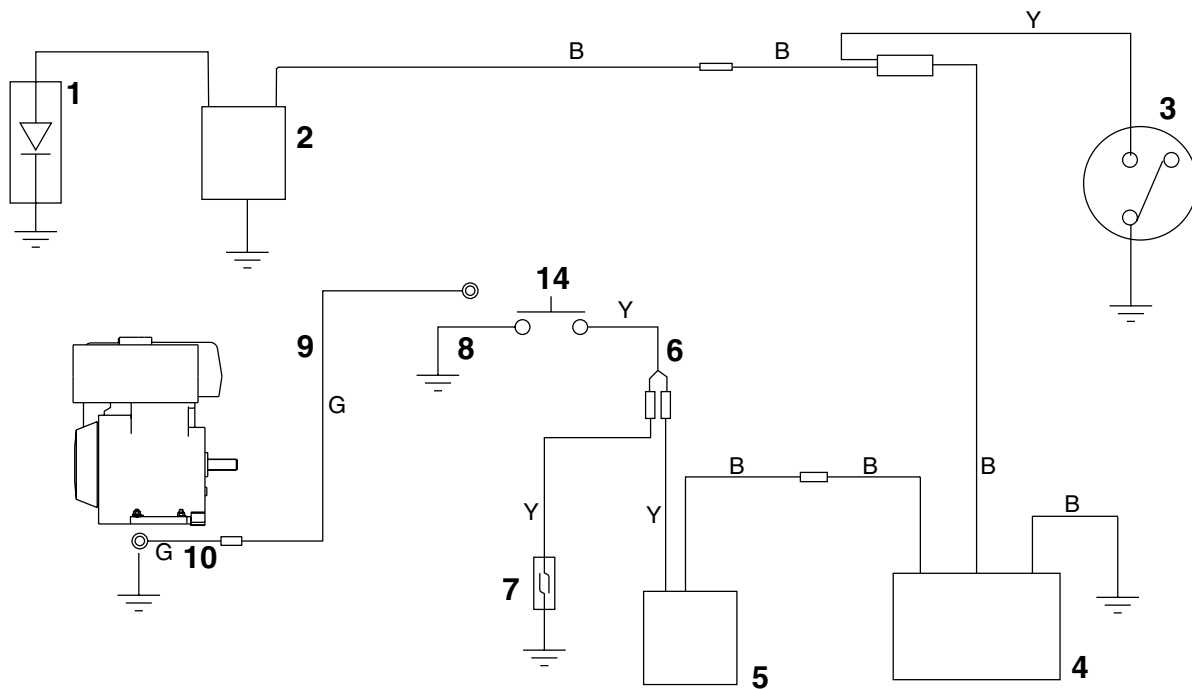

wc_gr003369

8.8 Engine Wiring Components

See Graphic: *wc_gr003369* and *wc_gr003370*

Ref.	Description	Ref.	Description
1	Spark plug	8	Handle
2	Ignition module	9	Handle ground wire*
3	Engine ON/OFF switch	10	Engine ground wire*
4	Engine control module	11	Harness (loom)
5	Oil alert unit	12	Cable tie
6	To stop switch	13	Engine mount plate
7	Low oil switch	14	Stop switch

* Used on newer machines. On older machines, the handle serves as the connection to ground.

8.9 Replacing the Gearbox

See Graphic: *wc_gr003359*

Removal:

- 8.9.1 Remove the handle. See section *Replacing the Lower Handle*.
- 8.9.2 Remove the spider. See section *Removing the Spider*.
- 8.9.3 Remove the clutch as described in section *Replacing the Standard Clutch*.
- 8.9.4 Remove the screw **(54)** and the washer **(70)** from the pulley **(24)**.
- 8.9.5 Remove the pulley **(24)** from the input shaft using a three-jaw puller. Remove the key **(82)**. Inspect the key and keyways for signs of shearing. Replace the key if deformed or edges are rounded.
- 8.9.6 Remove the screws **(50)** that secure the beltguard plate **(4)** to the engine and remove the beltguard plate.
- 8.9.7 Remove the engine as described in section *Engine Removal*.
- 8.9.8 Remove the screws **(56)** that secure the gearbox to the guard ring **(1)** and lift the guard ring off of the gearbox.

Installation:

- 8.9.9 Secure the gearbox **(1)** to the guard ring with the screws **(56)**.
- 8.9.10 Install the engine as described in section *Engine Installation*.
- 8.9.11 Secure the beltguard plate **(4)** to the engine with the screws **(50)**.
- 8.9.12 Install the pulley **(24)** to the input shaft with the key **(82)**, the screw **(54)**, and the washer **(70)**.
- 8.9.13 Install the clutch as described in section *Replacing the Standard Clutch*.
- 8.9.14 Install the spider. See section *Installing the Spider*.
- 8.9.15 Install the handle. See section *Replacing the Lower Handle*.

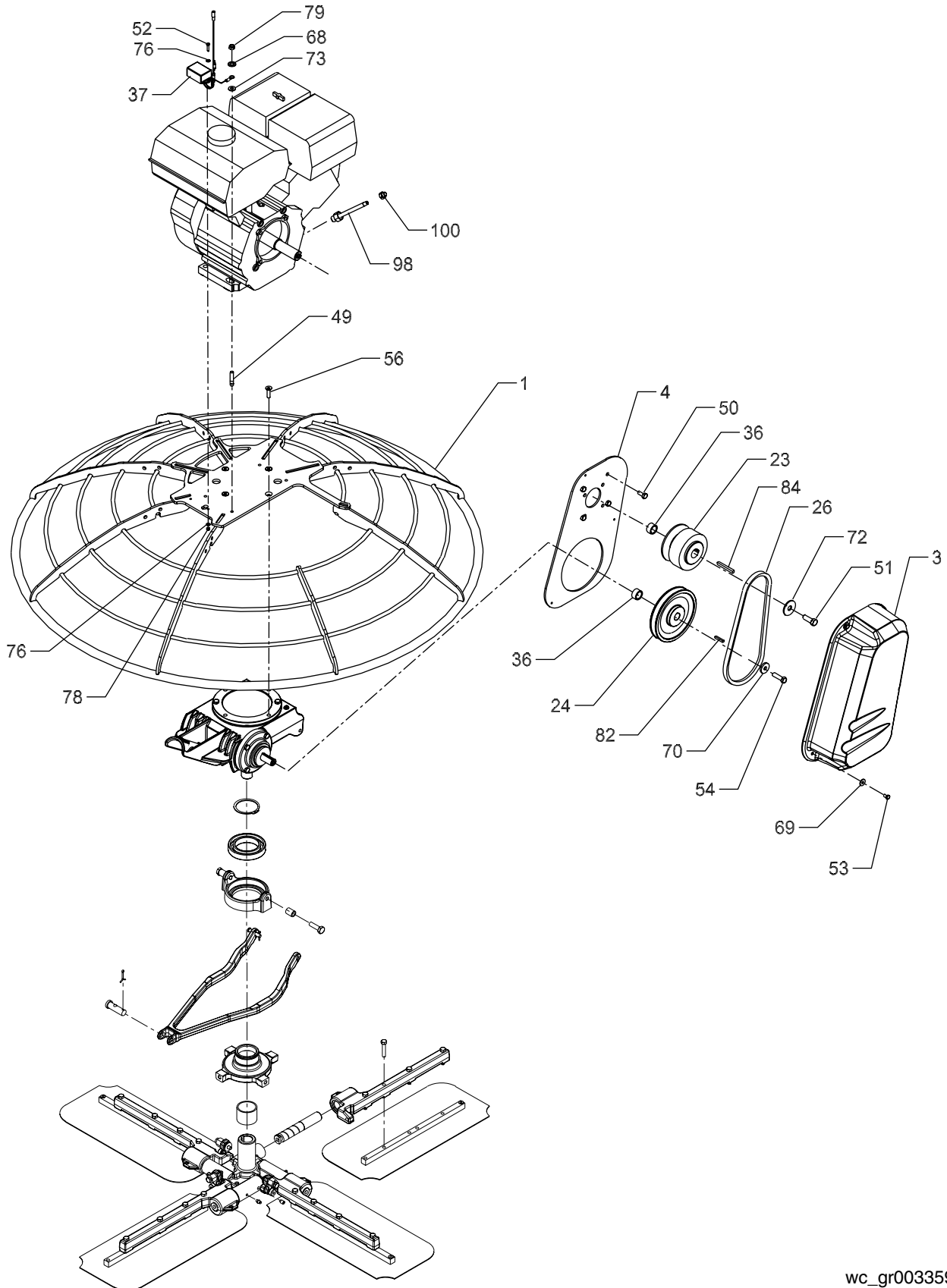

wc_gr003359

8.10 Gearbox—Exploded View

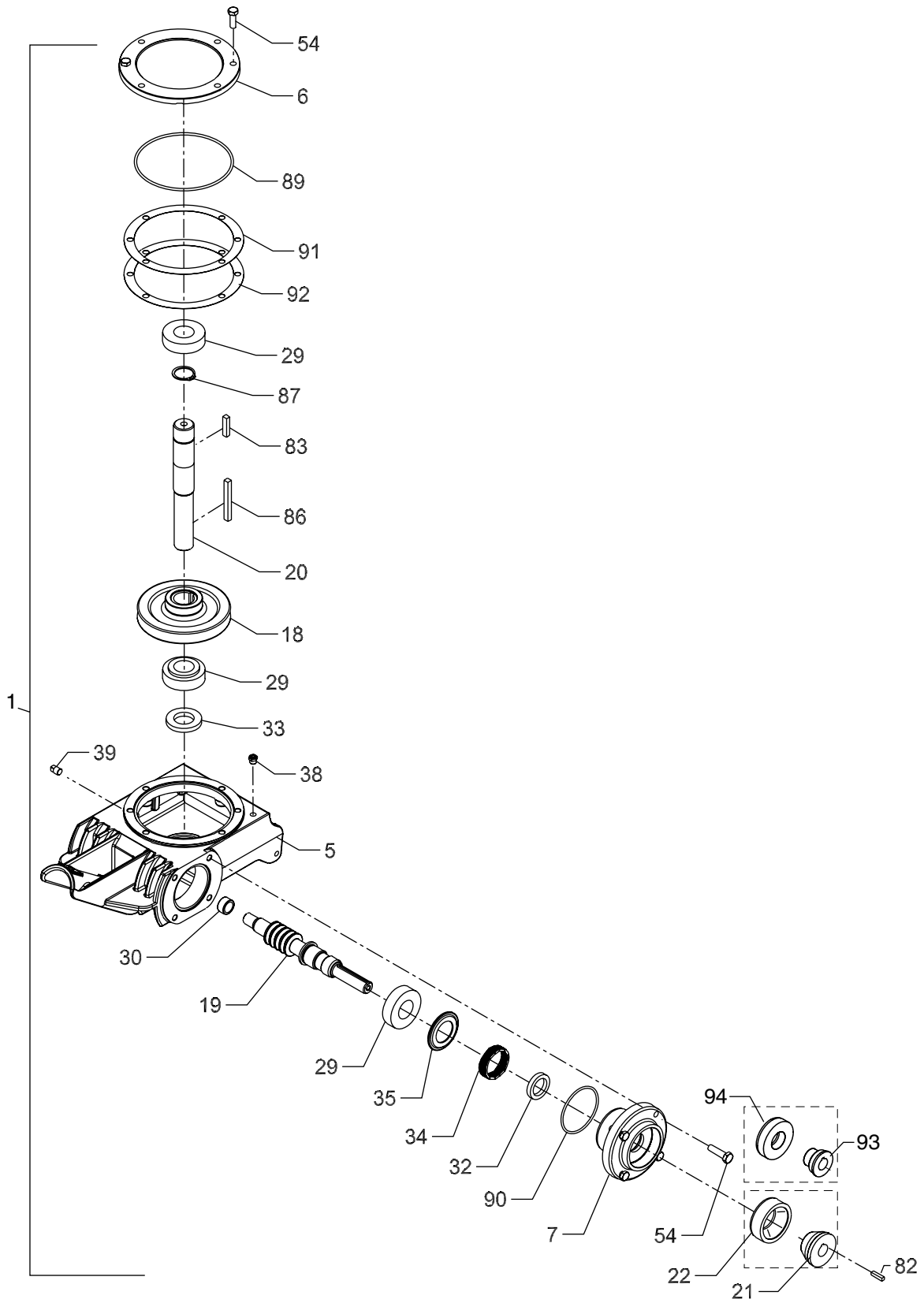

wc_gr003367

8.11 Gearbox—Components

Ref.	Description	Ref.	Description
1	Gearbox complete	35	Spacer
5	Gearbox	38	Relief valve
6	Gearbox cover	39	Plug (threaded)
7	Gearbox cover	54	Hex head screw
18	Worm gear	82	Key
19	Input shaft	83	Key
20	Output shaft	86	Key (square)
21	Brake cone	87	Retaining ring
22	Brake cup	89	O-Ring
29	Roller bearing	90	O-Ring
30	Needle bearing	91	Shim
32	Seal	92	Shim
33	Seal	93	Brake pad
34	Spring	94	Brake disc

8.12 Gearbox Disassembly

See Graphic: *wc_gr003157 and wc_gr003366*

There are two very similar gearboxes used on CT trowels. Early versions used a cup-and-cone-style brake **(a)**, later versions a disc-type brake **(b)**. Any differences in the procedures to rebuild the gearboxes are called out.

The following procedures require a hydraulic press and medium-sized and small-sized hammer-type gear pullers.

8.12.1 Remove the gearbox **(5)** as described in section *Replacing the Gearbox*.

8.12.2 Remove the drain plug **(39)** and allow the oil to drain out. Open or remove the pressure relief valve **(38)** to facilitate draining.

Note: *In the interests of environmental protection, place a plastic sheet and a container under the machine to collect any liquid which drains off. Dispose of this liquid in accordance with environmental protection legislation.*

8.12.3 Remove the screws **(54)** from the top cover **(6)** and remove the top cover. Inspect the O-ring **(89)** and the shims **(91, 92)**; replace them if worn or damaged. Using a hammer-type gear puller **(c)**, pull the bearing race **(d)** from the top cover.

8.12.4 Lift the output shaft assembly **(e)** from the gearbox.

8.12.5 Using a hydraulic press, press the worm gear **(18)** and the lower roller bearing **(29a)** from the output shaft **(19)**.

Note: *There is a retaining ring **(87)** mounted to the output shaft that secures the position of the worm gear. It is hidden from view when the worm gear and the roller bearings are mounted to the output shaft. Be sure to press the worm gear and the lower roller bearing off along the length of the output shaft to prevent contact with the retaining ring.*

8.12.6 Using a hydraulic press, press the upper roller bearing **(29b)** from the output shaft.

8.12.7 Remove the retaining ring **(87)**.

8.12.8 Remove the seal **(33)** from the gearbox.

8.12.9 Using a press, press the bearing race **(f)** from the gearbox.

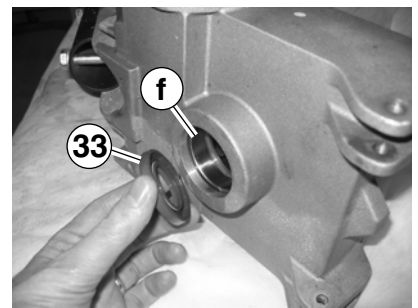
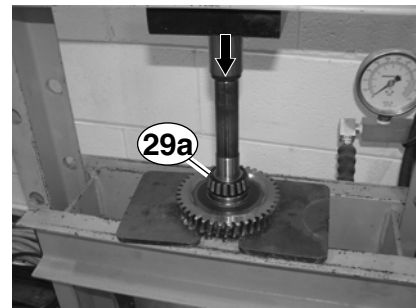
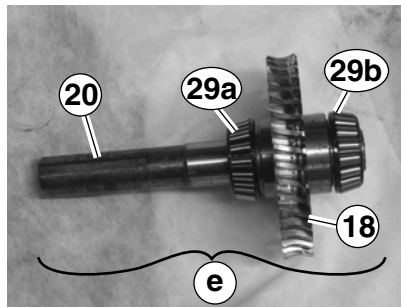
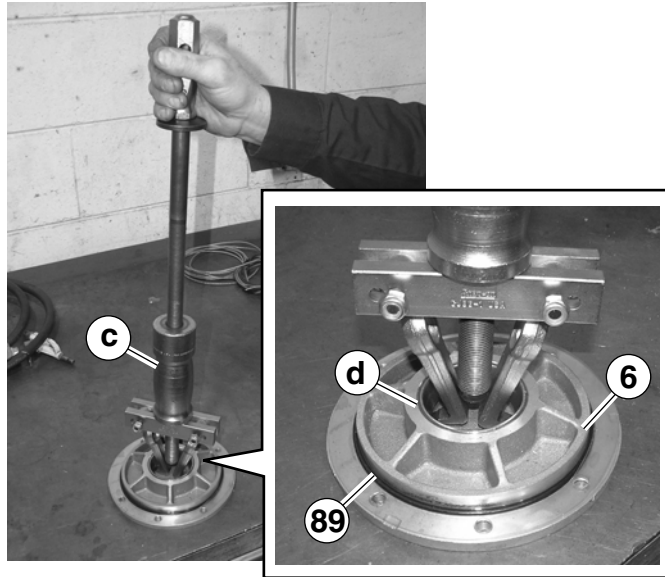
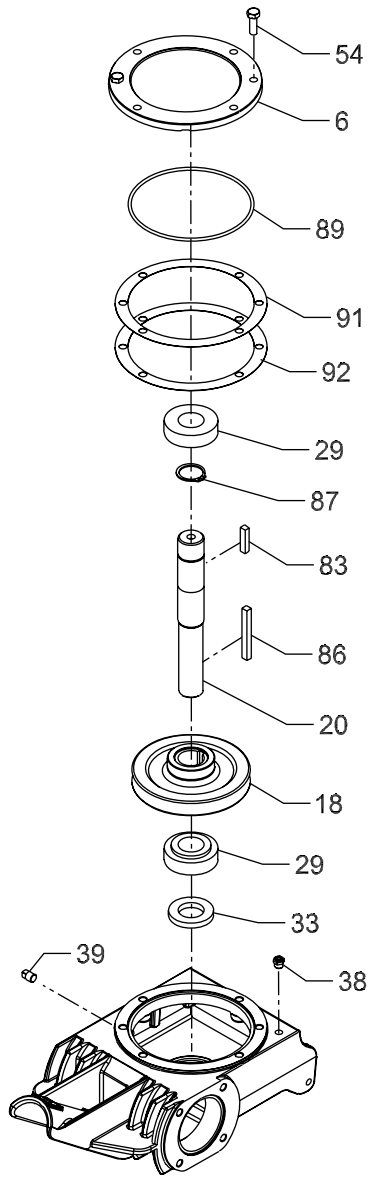

wc_gr003157

- 8.12.10 Remove the screws **(54)** from the side cover **(7)** and remove the side cover. Inspect the O-ring **(90)** and replace it if it is worn.
- 8.12.11 For gearboxes with cup-and-cone–style brakes **(a)**, press the brake cup **(22)** from the side cover using a hydraulic press.
For gearboxes with disc-type brakes **(b)**, press the brake disc **(94)** from the side cover using a hydraulic press.
- 8.12.12 Remove the seal **(32)** from the cover.
- 8.12.13 Remove the spring **(34)** from the gearbox.
- 8.12.14 Remove the input shaft assembly **(g)** from the gearbox and remove the spacer **(35)** from the input shaft assembly.
- 8.12.15 Using a hydraulic press, press the roller bearing **(29)** from the input shaft.
- 8.12.16 Using a hammer-type gear puller **(h)**, pull the needle bearing **(30)** from the gearbox.
- 8.12.17 Clean the parts with an appropriate cleaning solvent.
- 8.12.18 Inspect all of the gears, bearings, O-rings, seals and shims for wear or damage; replace any worn or damaged component.

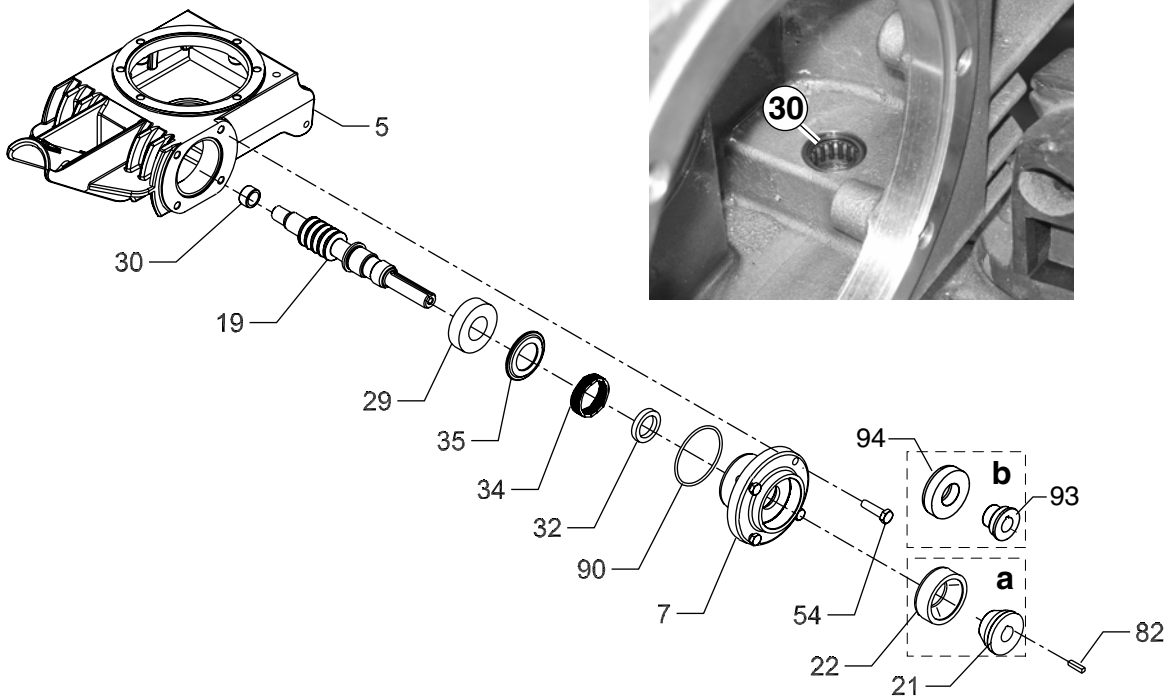
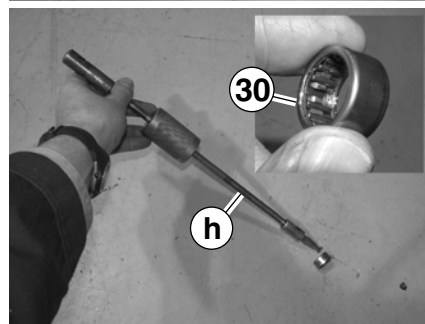
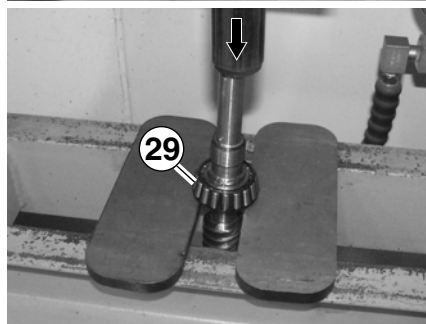
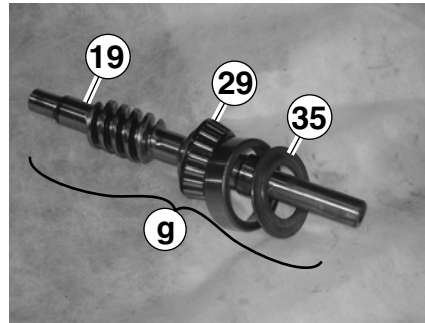
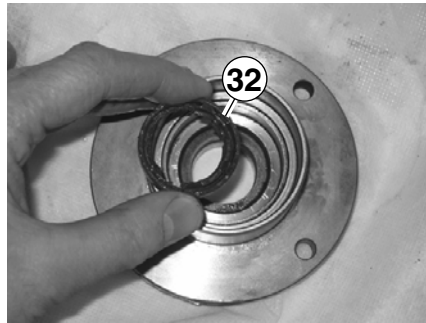
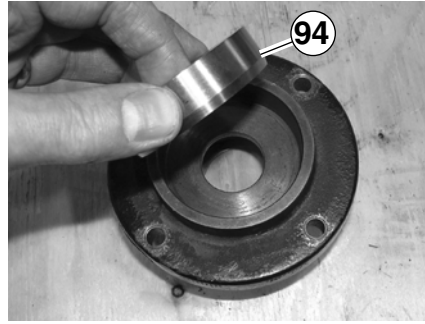
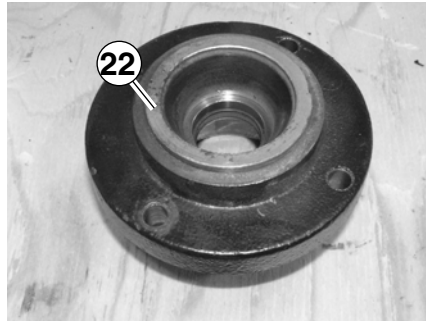

wc_gr003366

8.13 Gearbox Assembly

See Graphic: *wc_gr003367* and *wc_gr003368*

- 8.13.1 Install a new needle bearing **(30)** into the gearbox.
- 8.13.2 Press the roller bearing **(29)** onto the input shaft **(19)**.
- 8.13.3 Press the roller bearing race into the gear box.
- 8.13.4 Install a new seal **(32)** and O-ring **(90)** into the side cover **(7)**.
- 8.13.5 Add the spacer **(35)** to the input shaft assembly and install the input shaft assembly into the gearbox. Also insert the spring **(34)**.
- 8.13.6 Install a new seal **(33)** into the gearbox.
- 8.13.7 Install the retaining ring **(87)** onto the output shaft **(20)**.
- 8.13.8 There is a recess **(a)** in the worm gear **(18)** in which the retaining ring fits. Be sure to position the worm gear so that the recess faces the short side of the output shaft. Install the key **(86)** and press the worm gear onto the output shaft so that it fits tightly to the retaining ring.
- 8.13.9 Heat the two roller bearings **(29)** on a hot plate then install them onto the output shaft. Press the bearings if necessary so that they fit tightly to the worm gear.
- 8.13.10 Press the roller bearing race into the top cover. Also add O-ring **(89)** and shims **(91, 92)** to the top cover. If the shims are damaged or worn, replace them with the equivalent type and number of shims.
- 8.13.11 Position the output shaft assembly into the gearbox.
- 8.13.12 Before final installation, set the output shaft roller bearings. To do so, install the top cover **(6)** and secure it with the screws **(54)**. Torque the screws to 25 Nm (18 ft.lbs.). Set the roller bearing by striking the output shaft with a rubber mallet. You should be able to turn the output shaft by hand and there should be virtually no end or side play.
- 8.13.13 Remove the top cover.
- 8.13.14 Install the input shaft. Rotate the input and output shafts as necessary to align the gears.
- 8.13.15 Apply Loctite 243 or equivalent to screws **(54)** and install the side cover **(7)**. Torque the screws to 25 Nm (18 ft.lbs.). You should be able to turn the input shaft by hand.
- 8.13.16 Apply Loctite 243 or equivalent screws **(54)** and reinstall the top cover. Torque the screws to 25 Nm (18 ft.lbs.).
- 8.13.17 Fill the gearbox with 620 ml (21 oz.) of Glygoyle 460 synthetic oil.
- 8.13.18 Install the brake cone **(21)** or pad **(93)**.
- 8.13.19 Install the gearbox as described in section *Replacing the Gearbox*.

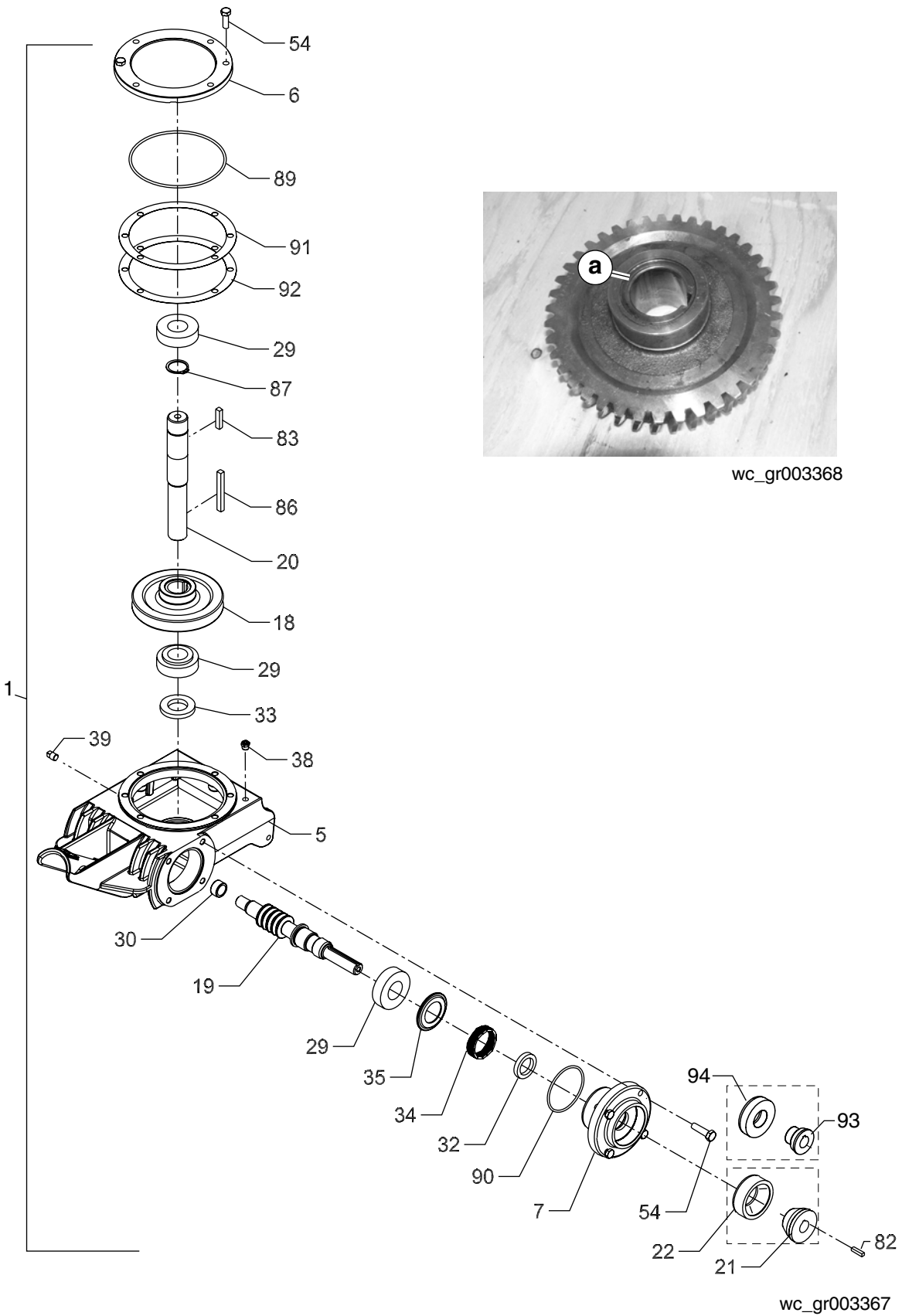

Notes

Threadlockers and Sealants

Threadlockers and Sealants

Threadlocking adhesives and sealants are specified throughout this manual by a notation of “S” plus a number (S#) and should be used where indicated. Threadlocking compounds normally break down at temperatures above 175°C (350°F). If a screw or bolt is hard to remove, heat it using a small propane torch to break down the sealant. When applying sealants, follow instructions on container. The sealants listed are recommended for use on Wacker equipment.

TYPE () = Europe	COLOR	USAGE	PART NO. – SIZE
Loctite 222 Hernon 420 Omnifit 1150 (50M)	Purple	Low strength, for locking threads smaller than 6 mm (1/4”). Hand tool removable. Temp. range: -54 to 149°C (-65 to 300°F)	73287 - 10 ml
Loctite 243 Hernon 423 Omnifit 1350 (100M)	Blue	Medium strength, for locking threads larger than 6 mm (1/4”). Hand tool removable. Temp. range: -54 to 149°C (-65 to 300°F)	29311 - .5 ml 17380 - 50 ml
Loctite 271/277 Hernon 427 Omnifit 1550 (220M)	Red	High strength, for all threads up to 25 mm (1”). Heat parts before disassembly. Temp. range: -54 to 149°C (-65 to 300°F)	29312 - .5 ml 26685 - 10 ml 73285 - 50 ml
Loctite 290 Hernon 431 Omnifit 1710 (230LL)	Green	Medium to high strength, for locking preassembled threads and for sealing weld porosity (wicking). Gaps up to 0.13 mm (0.005”) Temp. range: -54 to 149°C (-65 to 300°F)	28824 - .5 ml 25316 - 10 ml
Loctite 609 Hernon 822 Omnifit 1730 (230L)	Green	Medium strength retaining compound for slip or press fit of shafts, bearings, gears, pulleys, etc. Gaps up to 0.13 mm (0.005”) Temp. range: -54 to 149°C (-65 to 300°F)	29314 - .5 ml
Loctite 545 Hernon 947 Omnifit 1150 (50M)	Brown	Hydraulic sealant Temp. range: -54 to 149°C (-65 to 300°F)	79356 - 50 ml
Loctite 592 Hernon 920 Omnifit 790	White	Pipe sealant with Teflon for moderate pressures. Temp. range: -54 to 149°C (-65 to 300°F)	26695 - 6 ml 73289 - 50 ml
Loctite 515 Hernon 910 Omnifit 10	Purple	Form-in-place gasket for flexible joints. Fills gaps up to 1.3 mm (0.05”) Temp. range: -54 to 149°C (-65 to 300°F)	70735 - 50 ml

Threadlockers and Sealants



Threadlockers and Sealants (continued)

Threadlocking adhesives and sealants are specified throughout this manual by a notation of “S” plus a number (S#) and should be used where indicated. Threadlocking compounds normally break down at temperatures above 175°C (350°F). If a screw or bolt is hard to remove, heat it using a small propane torch to break down the sealant. When applying sealants, follow instructions on container. The sealants listed are recommended for use on Wacker equipment.

TYPE () = Europe	COLOR	USAGE	PART NO. – SIZE
Loctite 496 Hernon 110 Omnifit Sicomet 7000	Clear	Instant adhesive for bonding rubber, metal and plastics; general purpose. For gaps up to 0.15 mm (0.006”) Read caution instructions before using. Temp. range: -54 to 82°C (-65 to 180°F)	52676 - 1oz.
Loctite Primer T Hernon Primer 10 Omnifit VC Activator	Aerosol Spray	Fast curing primer for threadlocking, retaining and sealing compounds. Must be used with stainless steel hardware. Recommended for use with gasket sealants.	2006124-6 oz.

Torque Values

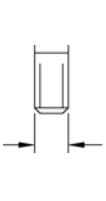
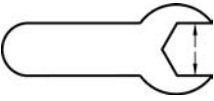
Metric Fasteners (DIN)

	TORQUE VALUES (Based on Bolt Size and Hardness)						WRENCH SIZE			
	8.8		10.9		12.9					
Size	Nm	ft.lb.	Nm	ft.lb.	Nm	ft.lb.	Metric	Inch	Metric	Inch
M3	1.2	*11	1.6	*14	2.1	*19	5.5	7/32	2.5	–
M4	2.9	*26	4.1	*36	4.9	*43	7	9/32	3	–
M5	6.0	*53	8.5	6	10	7	8	5/16	4	–
M6	10	7	14	10	17	13	10	–	5	–
M8	25	18	35	26	41	30	13	1/2	6	–
M10	49	36	69	51	83	61	17	11/16	8	–
M12	86	63	120	88	145	107	19	3/4	10	–
M14	135	99	190	140	230	169	22	7/8	12	–
M16	210	155	295	217	355	262	24	15/16	14	–
M18	290	214	405	298	485	357	27	1-1/16	14	–
M20	410	302	580	427	690	508	30	1-1/4	17	–

1 ft.lb. = 1.357 Nm





* = in.lb.

1 inch = 25.4 mm

Torque Values

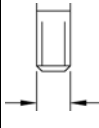
Torque Values (continued)

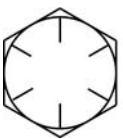
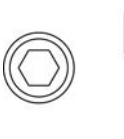
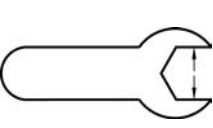
Inch Fasteners (SAE)

	 SAE 5		 SAE 8							
	Size	Nm	ft.lb.	Nm	ft.lb.	Nm	ft.lb.	Metric	Inch	Metric
No.4	0.7	*6	1.0	*14	1.4	*12	5.5	1/4	–	3/32
No.6	1.4	*12	1.9	*17	2.4	*21	8	5/16	–	7/64
No.8	2.5	*22	3.5	*31	4.7	*42	9	11/32	–	9/64
No.10	3.6	*32	5.1	*45	6.8	*60	–	3/8	–	5/32
1/4	8.1	6	12	9	16	12	–	7/16	–	3/32
5/16	18	13	26	19	33	24	13	1/2	–	1/4
3/8	31	23	45	33	58	43	–	9/16	–	5/16
7/16	50	37	71	52	94	69	16	5/8	–	3/8
1/2	77	57	109	80	142	105	19	3/4	–	3/8
9/16	111	82	156	115	214	158	–	13/16	–	–
5/8	152	112	216	159	265	195	24	15/16	–	1/2
3/4	271	200	383	282	479	353	–	1-1/8	–	5/8

1 ft.lb. = 1.357 Nm

* = in.lb.

1 inch = 25.4 mm

