



AUSSIE SCUD SERIES

The Pro's Choice

MARCH 2018

OPERATOR'S INSTRUCTION MANUAL



Covers:

- Scud 100
- Scud 350
- Scud 351
- Scud 400
- Ultra & **NEW Ultra A**
- Predator Plus



IMPORTANT:
TO REDUCE RISK OF INJURY, READ OPERATING
INSTRUCTIONS CAREFULLY BEFORE USING EQUIPMENT



REF: ASCUDMANVER6



AUSSIE ECO CLEAN SCUD & ULTRA SERIES OPERATING & MAINTENANCE INSTRUCTIONS

Contents:

Warranty	2	Stopping the machine	7
Safety precautions	3	Care & Maintenance	7/8
Specifications	3	Troubleshooting	8
Wheel & frame care	3	Parts identification	9
Assembly & preparation for use	4	Replacement parts	10
Machine preparation	4	Resetting the safety valve	11
Hose connections	5	Pump parts	12-13
Before starting the machine	5	Blaster Risk Assessment	14
Starting the engine	6	Warnings	16
Pressure washing	6	Pressure cleaner daily checks	16
Applying detergent	7	Three monthly regular service	16

CONGRATULATIONS on the purchase of an Aussie Scud professional high pressure water blaster. These top of the range machines have been designed to be easy to use, simple to service and offer reliability and performance.

Before attempting to operate your machine please read this Instruction Manual thoroughly following all directions carefully. By doing so you will ensure safe operation of the unit and will enjoy long and trouble free service from your heavy duty water blaster.

GUARANTEE ... EXCLUSIVE 4 YEAR PUMP WARRANTY

This Aussie Eco Clean product is guaranteed against faults in manufacture for **two years** from purchase. The **Bertolini** pump has a **four year warranty**, but must be serviced by an authorised service agent every six months to maintain this warranty. Keep your receipt as proof of purchase and all service receipts. This guarantee is invalid if the product is found to have been abused in any way, or not used for the purpose for which it was intended.



Routine maintenance is the owner’s responsibility. Failure to maintain the machine in line with the services outlined on the back page will invalidate warranty. High pressure accessories carry a 3 month warranty.

Where possible return faulty goods to the place of purchase. No products can be returned to us without our prior permission. The reason for return must be clearly state.

N.B. Warranty is not transferrable to third parties in the event of sale of the machine within the warranty period. Please note that any parts used in warranty repairs are guaranteed for a period limited by the original warranty of the parent product.

Engine warranty is the responsibility of the engine manufacturer. Unit must be returned to authorised engine dealer for evaluation of engine warranty. (Refer to engine handbook).

Battery warranty is covered by Federal/Ryde Batteries, call (02) 9879 5422 for your nearest outlet.

Our goods come with guarantees that cannot be excluded under the Australian Consumer Law. You are entitled to a replacement or refund for a major failure and for compensation for any other reasonably foreseeable loss or damage. You are also entitled to have the goods repaired or replaced if the goods fail to be of acceptable quality and the failure does not amount to a major failure.

The benefits under the Aussie Pump warranty are in addition to other rights under Australian Consumer Law.



SAFETY PRECAUTIONS - IMPORTANT

1. **NEVER** direct spray jet at any surface that may contain asbestos material.
2. **NEVER** direct the spray jet at any person or animal. Keep hands and feet clear of the cleaning nozzle at all times.
3. **NEVER** hold a finger over the high pressure nozzle.
4. **NEVER** direct the spray jet at the machine itself or any electrical equipment.
5. After use release the pressure in the high pressure hose by operating the gun trigger.
6. **DO NOT** attempt any mechanical repair. If you have a problem with your machine contact your local Aussie Eco Clean Service Division, phone (02) 8865 3500.
7. **NEVER** supply any liquid other than water to the pump inlet.
8. **DO NOT** run dry
9. **NEVER** pull the high pressure hose if it has formed kinks or nooses.
10. **NEVER** pull the hose over sharp objects.
11. **DO NOT** attempt to disconnect any hose or coupling with pressure still in the hose.
12. **DO NOT** join hoses together to extend the length (buy an extra long hose)
13. **DO NOT** operate the machine whilst standing on ladders, use a platform tower or scaffolding.
14. Operate in well ventilated areas only.
15. **DO NOT** fill the fuel tank while engine is running
16. **DO NOT** try to repair a leak in the hose or connection while the system is under pressure.
17. **DO NOT** substitute any component part on this machine. Use of incorrect parts could cause serious personal injury.
18. Children should **NOT** be allowed to use the machine.
19. We recommend the use of safety goggles and steel cap boots when using the machine.



SPECIFICATIONS

Model	Petrol Engine version	Safety Classification (AS/NZ4233.1)	Diesel Engine versions	Pump Model	Pump Pressure (psi)	Flow rate (lpm)	Pump rpm
Scud 100	Honda GX200	Class A	Yanmar L48	WBL1114	2000	11	1450
Scud 350	Honda GX390	Class A	Yanmar L100 e/s	TTL1520	3000	15	1450
Scud 351	Honda GX390	Class A	Yanmar L100 e/s Hatz 1B50	TTL2120	2500	21	1450
Scud 400	Honda GX390	Class A	Yanmar L100 e/s Hatz 1B40	TTL1330	4000	15	1450
Ultra	Honda GX630 e/s	Class B	-	TTK2130	4300	21	1450
Ultra A	Honda GX630 e/s	Class A	-	TTL2028	4000	20	1450
Predator Plus	Honda GX690 e/s Vanguard 27HP	Class B	Kohler KD477	RAL2035 RAL2535	5000	21	1450



CARE OF FRAME & FLAT FREE TYRES ... MAINTAIN OPTIMUM PERFORMANCE

Aussie Scud blasters now come fitted with top quality **flat free tyres**. To maintain tyre shape ...

1. Ensure that straps used to secure the unit during transit are not over tightened to the point where

tyres misshape.

2. Do not leave the unit strapped down for extended periods.
3. Do not drop the unit; this could cause frame distortion or damage to bearings.



ASSEMBLY AND PREPARATION FOR USE

Before proceeding with assembly of your new Aussie Eco Scud high pressure blaster, check that all parts listed below are included.

- 1 x gun handle assembly
- 1 x high pressure hose
- 1 x dual lance & nozzle assembly



HEAVY DUTY LANCE: To assemble the gun/lance, 2. screw together and check nozzles have been fitted to end of lance.

A. Machine Preparation (initial start-up)



1. Check the oil in the pump and gearbox. Note separate reservoirs. With the machine on a level surface the oil lever should cover the red spot in the oil level sight glass on the side of the machine. If necessary, top up with SAE 75W-90.

Do not mix different grades of oil as this may affect the machines performance. If alternative oil is used, first empty out oil by unscrewing drain plug in bottom of machine.



Ensure breather plug is fitted to pump. **WARNING:** Before operation ensure top mounted travel plug is replaced by breather plug. Failure to fit breather and keep clean can result in over pressuring of oil chamber (crank case) and can blow oil seals. This will void warranty.

3. Note that the gearbox has a separate oil reservoir. Gearbox oil is SAE 90 gear oil.
4. Connect battery leads on electric start machines.
5. Check oil level in engine and fill with proper grade oil if necessary. (SAE 10W-30 for Honda engines, check engine manual for other makes)
6. Check fuel level and fill if necessary. (unleaded petrol)

Aussie Safety Protection Kit

Unloader - factory set, DO NOT adjust

- Detergent injector
- HP hose connection
- Supply hose connection
- Y strainer



B. Hose Connections

1. Connect high pressure hose to machine outlet.
2. If optional low pressure downstream, in-line chemical injector is to be used, connect the injector tube to the detergent inlet and place the other end of the tube, with the strainer attached, in the chemical container (not supplied).
3. Connect gun/lance assembly to high pressure hose.
4. Check inlet water filter is clean then connect water supply hose to machine. Use a 25mm (minimum) hose .

Incoming water supply must deliver double the flow of the machine. If questionable, check supply at machine. If supply is insufficient, do not operate from this outlet. For residential use, the outlet closest to the meter will usually deliver the highest flow rate. Connect only to clean town water supply.



Warning: Do not operate from tank or pond. Doing so will cavitate the pump causing damage. Cavitation or pump starvation is not covered by warranty. Cavitation is a phenomenon causing vacuum pockets to form within the pump that eventually implode under pressure pitting the internal pump surfaces.

Fitting instructions for optional hose reel

1. Securely clamp the hose reel mounting bar across the top of the Scud frame using the two sets of nuts and bolts supplied. Aussie Pumps recommends using Loctite on the bolts to prevent them vibrating loose.

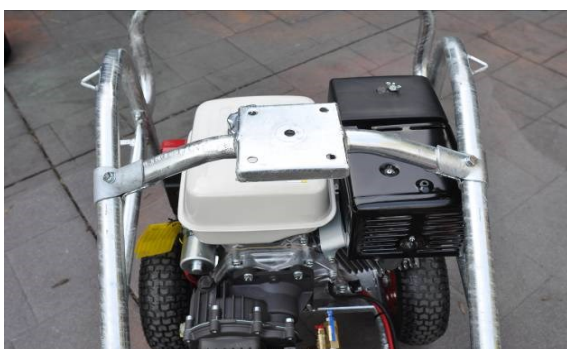

2. Fit hose reel to the mounting bar using the four sets of nuts and bolts supplied. Ensure all bolts are securely tightened and use Loctite to prevent them vibrating loose. The reel should be positioned so that it rotates fore/aft to aid fitting whip hose.



3. Connect whip hose to high pressure outlet on pump.



4. Fit handle to reel.
5. Fit gun to hose using C1500.24 nipple.
6. Start up machine (see below) and check for leaks. All leaks must be rectified before using machine.

C. Before starting the machine

OPERATE IN WELL VENTILATED AREAS ONLY.

1. Ensure machine is level
2. Turn on water supply.
3. Pull gun trigger until water starts to flow in a steady stream then release trigger.

HIGH PRESSURE SPRAY CAN PENETRATE THE SKIN & CAUSE SERIOUS INJURY!

Never point the spray gun at yourself, other people or animals.

Should the spray penetrate the skin **SEEK MEDICAL ATTENTION IMMEDIATELY!**

WARNING:

CHECK NOZZLES AND REPLACE IF WORN

If pressure drops off, check nozzle for wear. Nozzles should be replaced on a regular basis (every month for machines in regular use, every 3 months for machines used intermittently. Using the machine with the incorrect nozzle size or worn nozzle will void warranty and can be dangerous to the operator.

D. Starting the engine

(for Honda , refer to engine manual for other engine options)

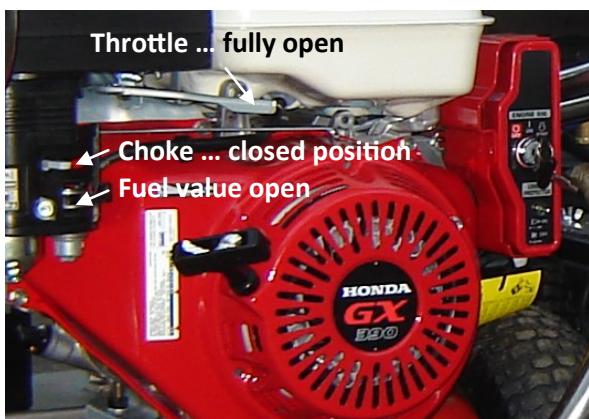

1. Ensure fuel valve is open
2. Move the choke on the engine to the closed position. If engine is warm, move choke half-way.
3. Turn engine ON/OFF switch to ON
4. Hold the gun trigger on.
5. Start engine, either turn engine key or pull the recoil starter grip lightly until resistance is felt, then pull briskly.
6. After engine starts, release the gun trigger and slowly open the choke.
7. Warm up engine for 3 minutes without load.

KEEP THE MACHINE OUT OF MOISTURE LADEN ATMOSPHERES

E. Pressure washing

WEAR PROPER FACE PROTECTION WHEN OPERATING PRESSURE WASHER!

Machine is now ready for operation.

1. For high pressure jetting rotate side grip on dual lance backwards until it stops. Fine control of pressure/flow can be made with small adjustments to the rotation of the grip. There is no pressure adjustment available on single lance options.
2. When low pressure and high flow is required, including detergent application, unwind grip two complete turns. Adjust the detergent control on the pump as required.



NOTE: Check the system for water leaks, fuel leaks, oil leaks, hose kinks, etc. Correct any problems before proceeding.

UNLOADER SETTING

The high pressure unloader on the machine is factory set to operate the pump at it's rated pressure.

DO NOT ADJUST. Tampering with the unloader will void warranty and can be dangerous.

WARNING DO NOT RUN EXCESSIVE BY-PASS

SWITCH MACHINE OFF WITHIN TWO MINUTES OF CEASING OPERATION AS EXCESSIVE BY-PASS CAN CAUSE HEAT BUILD UP IN PUMP AND SUBSEQUENT DAMAGE.

EXCESSIVE BY PASS RUNNING VOIDS WARRANTY!!

F. Applying detergent

(not available on Predator Plus)

1. Prepare pressure washer detergent solution as required by manufacturer.
2. Place detergent siphon tub/filter into solution.
3. Adjust double lance to low pressure setting.
4. Apply cleaning solution to a dry surface, starting at lower portion of areas to be washed and work upward, using long overlapping strokes.
5. Allow time to detergent to activate and then rinse off. DO NOT allow detergent to dry on.

IMPORTANT; You must flush the injection system after each. Place the siphon hose into a bucket of clean water, then run pressure washer in low pressure for 2 minutes.

G. Stopping the machine

1. If using the detergent injector, flush out the chemical by running clean water through the system.
2. Allow machine to run for 1 minute without load to cool before stopping.
3. Turn engine ON/OFF switch to OFF
4. If your machine has a recoil start, pull recoil start until compression resistance is felt. Store the machine in this position to help prevent valve warpage or sticking.
5. Close fuel valve.
FAILURE TO CLOSE THE FUEL VALVE ON THE ENGINE CAN CAUSE FUEL LEAKAGE WHEN THE MACHINE IS BEING TRANSPORTED!
6. Turn off water supply.
7. Pull gun trigger to release all pressure in the system, then LOCK THE TRIGGER.
8. Hoses may now be disconnected from the machine.



Failure to release pressure before disconnecting the hose quick coupler will result in the quick coupler o-ring seal blowing out. This o-ring must be replaced before operating machine.

CARE AND MAINTENANCE:**AFTER EACH USE**

If cleaning agents have been mixed with the incoming water, it is essential to flush the machine with clean water after use.

If there is a danger of freezing anti-freeze should be mixed with the flush water or the machine must be completely drained.

After the final flush stop the machine. DO NOT allow the machine to idle for more than 15 seconds. This is particularly important when there is a danger of freezing. Do not run for longer without water supply.

STORAGE

Store the washer in an upright position, preferably drained of water if there is a danger of freezing (or fill with anti-freeze).

PUMP CRANKCASE LUBRICATION

Proper pressure washer pump crankcase lubrication will help extend the working life of the machine. Follow these important guidelines. We recommend keeping a simple service log book.

- ♦ Change oil in pump after initial 50 hour run-in period. (SAE 75W-90)
- ♦ Change pump oil every 3 months, use high quality oil. (SAE 75W-90)
- ♦ Pump oil level can be checked with the dip stick under the breather cap or by viewing the oil sight gauge where fitted. The oil level is correct if level is in the centre of the gauge. If oil level is low, fill to correct level with recommended oil (SAE 75W-90). **DO NOT OVERFILL CRANKCASE!**
- ♦ Replace oil in gearbox (separate chamber) with SAE 90 gear oil every three months.

PREVENTATIVE MAINTENANCE

- ◆ Keep filter in supply hose connection clean, rinse regularly.
- ◆ Use correct size nozzles for machine and replace when worn, check serial tag for correct size.
- ◆ Drain water from pressure hoses, gun/lance assembly and accessories after use.
- ◆ Protect pump from freezing. Failure to remove water from the pump in freezing temperatures will result in damaged pump manifold.
- ◆ Use ONLY injector of the size and type designed for this model.
- ◆ **DO NOT** tamper with unloader valve adjustment or alter engine speed.
- ◆ **DO NOT** siphon chemicals through the pump, it is designed for water only.
- ◆ Incoming water supply must not exceed 60°C, otherwise pumps seal damage could result
- ◆ Follow engine manufactures guidelines for engine maintenance. (see engine manual)

TROUBLE SHOOTING GUIDE (for engine troubleshooting refer to engine manual)

FAULT	CAUSE	REMEDY
Pump running normally but pressure low on installation	Pump sucking air Valves sticking Unloader valve seat faulty Nozzle incorrectly sized Worn piston packing	Check water supply & possibility of air ingress. Check & clean or replace if necessary Check & replace Check & replace Check & replace
Fluctuating Pressure	Valves worn Valves blocked Pump sucking air Worn piston packing	Check & replace Check & replace Check water supply & air ingress at joints in suction line Check & replace
Pressure low after period of normal use	Nozzle worn Check valves worn Check valves blocked Unloader valve seat worn Worn piston packing Pistons cracked as a result of dry running	Check & replace Check & replace Check & clean Check & replace Check & replace Replace pistons
Pump Noisy	Air in suction Broken or weak suction or delivery valve spring Foreign matter in valves Worn bearing Excessive temperature of liquid	Check water supply & connections on suction line Check & replace Check & clean Check & replace Reduce temperature
Presence of water in oil	Oil seal worn High humidity in air Piston packing worn	Check & replace Check & change oil twice as often Check & replace
Water dripping below pump	Safety valve activated due to pressure spike Thermal dump activated Piston packing worn O.R plunger retainer worn	Reset safety valve (see page 11), if it keeps activating replace unloader Activates if water temperature exceeds 60°C. Should self reset once water in pump cools. If not, replace Check & replace Check & replace
Oil Dripping	Travel plug in use on pump Oil seal worn	Replace with breather plug Check & replace if necessary
Unloader switches repeatedly when gun is off	Leaking gun &/or pressure pipe. Leaky sleeve Worn out kick-back valve body Leaky seals	Renew gun, seal pressure pipe Renew sleeve Check & renew as necessary kick-back valve plate & seat Renew seals
Leaky piston rod	Defective O-Ring/Support Ring	Renew piston rod seals & examine surfaces in guide case
Leaky by-pass at nominal pressure	Nozzle too small, too much water. Worn out by-pass valves	Install larger nozzle Examine & renew as necessary
Pressure gauge shows high pressure fluctuations when shutting off gun	Valve set too high above operating pressure Dirty valve	Adjust the unloader at the operating pressure. Clean valve (removing lime deposits etc). Grease parts before installing.
Pressure in supply line when running on by-pass	Dirty or worn low pressure valves	Remove & clean or replace low pressure valves
Engine will not start	Out of fuel Engine defect	Fill tank with petrol/diesel Return to engine service agent

PARTS IDENTIFICATION

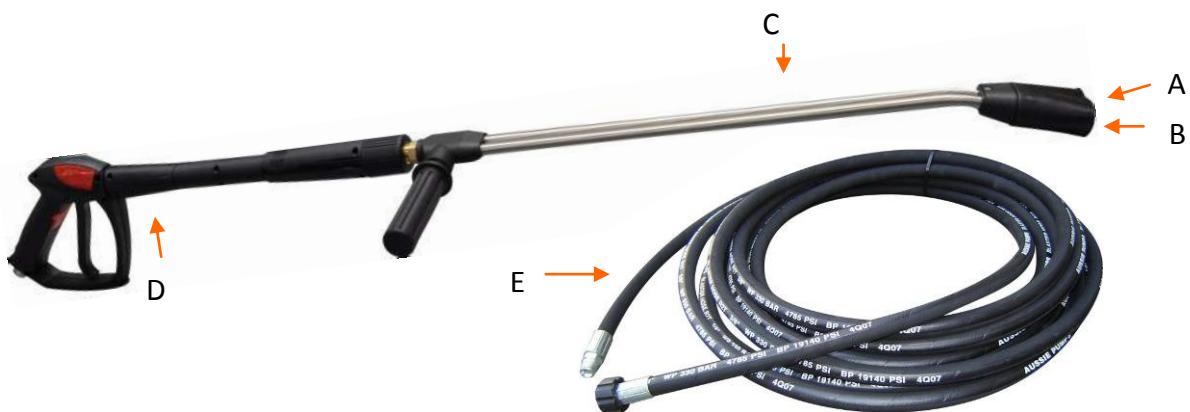
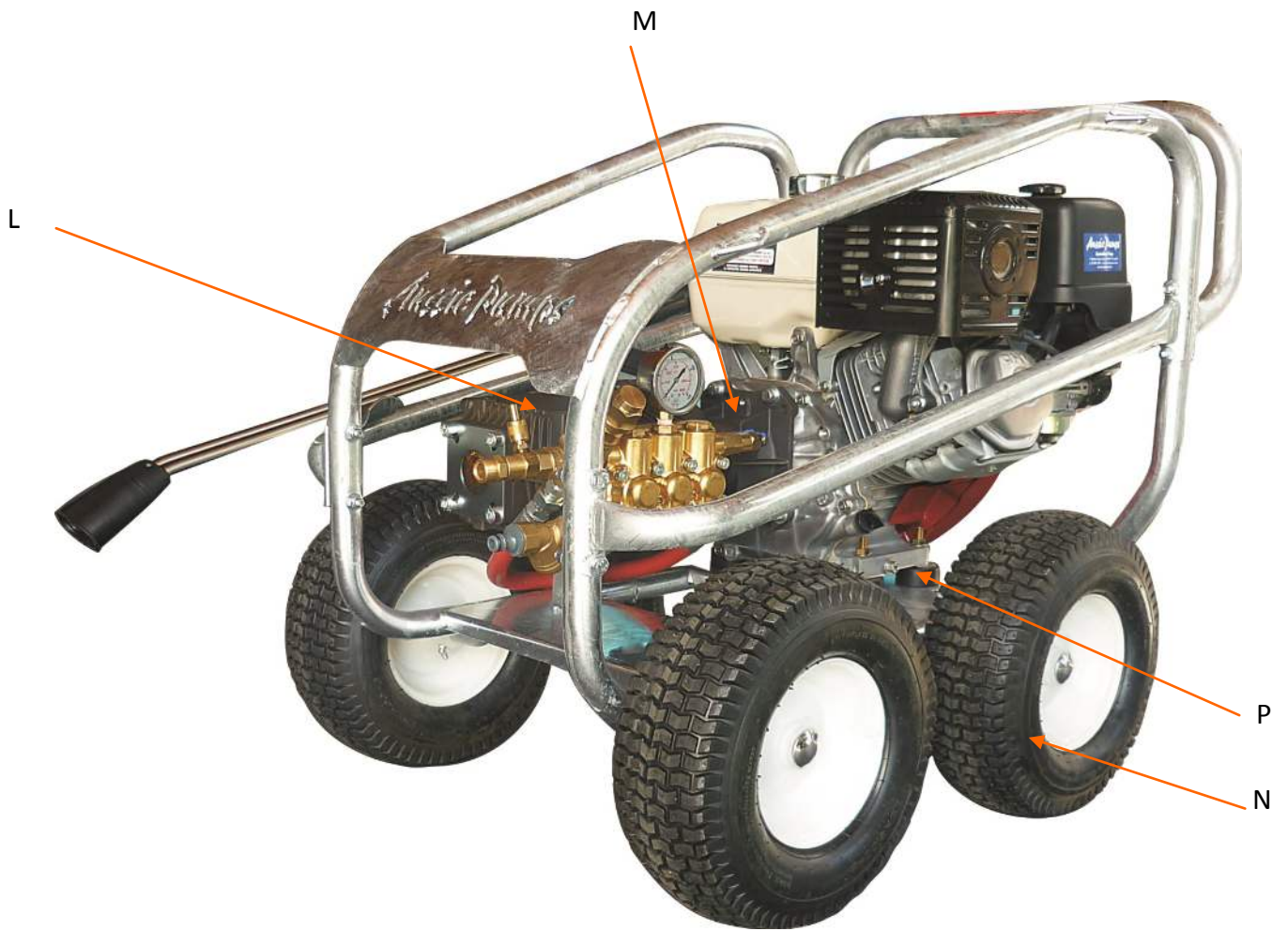

REPLACEMENT PARTS

Position	Part No	Description	SCUD Series				400 Yanmar	NEW Ultra A	Ultra	Predator +
			100	350	351	400				
Nozzles										
A	C915030M	HP NOZZLE (15°ANGLE, TIP SIZE 30)					x			
	C915045M	HP NOZZLE (15°ANGLE, TIP SIZE 45)		x						x
	C915065M	HP NOZZLE (15°ANGLE, TIP SIZE 65)			x					
	C915035M	HP NOZZLE (15°ANGLE, TIP SIZE 35)				x				
	C915055M	HP NOZZLE (15°ANGLE, TIP SIZE 55)						x	x	
B	C915500MSS	LP DETERGENT NOZZLE		x	x	x	x	x	x	
Lance										
C	C4723.45.115	VARIO LANCE (NO NOZZLE REQUIRED)	x							
	C3924.01	684MM SS DOUBLE LANCE C/W BOOT		x	x	x	x	x	x	
	C3905.15	900M SS SINGLE LANCE								x
Gun										
D	M4021108007	AL13 GUN WITH MELTED HANDLE & M22	x							
	M4022209003	AL55 GUN WITH MELTED HANDLE & M22		x	x	x	x	x	x	
	CGPDG5010	5000 PSI RATED AL35 GUN & QC								x
Hose										
E	AHW06FB6FB6X10	10 MTR HP HOSE (R2, 5800 PSI)	x	x	x	x	x	x	x	x
Unloader										
F	BAPRI20ADJ	UNLOADER VALVE (2000 PSI)	x							
	M215010400	VRT 3 UNLOADER VALVE (4000 PSI)		x	x					
	BVB350	UNLOADER VALVE (5100 PSI)				x	x	x	x	x
Thermal Dump Valve										
G	MPA60063050	3/8" THERMAL DUMP VALVE	x							
	MPA60063070	1/2" THERMAL DUMP VALVE		x	x	x	x	x	x	x
Safety Valves										
H	MTM00033003	3600 PSI SAFETY VALVE	x	x	x					
	MPA60156000	4000 PSI SAFETY VALVE				x	x	x	x	
	BVS350	5650 PSI SAFETY VALVE								x
Inlet Strainer										
I	AYSTRAINER-200	1/2" FEMALE BRASS Y STRAINER	x	x						
	AY STRAINER 3/4	STRAINER 3/4"			x	x	x	x	x	x
Gauge										
J	AGCDR0102	6000 PSI GAUGE		x	x	x	x	x	x	x
Chemical Injector										
K	FZX1763	INJECTOR		x	x	x	x	x	x	
Pumps										
L	BWBL1114	BERTOLINI PUMP (2000 PSI, 11 LPM)	x							
	BTTL1520	BERTOLINI PUMP (3000 PSI, 15 LPM)		x						
	BTTL2120	BERTOLINI PUMP (3000 PSI, 21 LPM)			x					
	BTTL1330	BERTOLINI PUMP (4000 PSI, 13 LPM)				x	x			
	BTTL2028	BERTOLINI PUMP (4000 PSI, 20 LPM)						x		
	BTTK2130	BERTOLINI PUMP (4300 PSI, 21 LPM)							x	
	BRAL2035-P	BERTOLINI PUMP (5000 PSI, 20 LPM)								x
Gearboxes										
M	B318699973	GEARBOX (3/4" PTO)	x							
	B318870973	GEARBOX (1" PTO)		x	x	x	x			
	B319110973	GEARBOX (1" PTO)						x	x	
	B318880973	GEARBOX (1 1/8" PTO)								x
Wheel										
N	A400015	10" WHEEL	x							
	A400016	13" WHEEL		x	x	x	x	x	x	x
Engine Mounts										
P	AENGMOUNTBB300	ENGINE MOUNTS (4 NEEDED)	x	x	x	x		x	x	x

Order the right part first time ...

specify the pump model number when ordering parts.

Full parts breakdown available online ... www.aussiepumps.com.au

Resetting the Safety Valve

The **safety valve** prevents damage to the pump seals and valves caused by a pressure spike.

The safety valve should only be reset after checks to ensure the unloader valve is working correctly. **If in doubt contact, your nearest Aussie Eco-clean service centre.**

The following steps should be taken to reset the safety valve, with the unit running.

1. Unscrew the lock nut (C) on the safety valve and the adjusting screw (D), should be screwed in all the way.
2. Using an allen key, loosen the lock nut (B) on the unloader and wind the unloader knob (A) in gradually until the required pressure is obtained whilst the trigger is pulled and water is running through the pump. Do not exceed the maximum rated pressure of the pump.
3. The lock nut (B) should then be wound down until it grounds out at the bottom (do not over tighten as this will further adjust the pressure) and locked with use of the allen key. Paint mark across the nut and knob to identify any tampering with the setting.
4. With the pump running at the required

pressure, the adjusting screw (D) on the safety valve should be wound out until there is a slight drip. Screw it in one quarter of a turn, or until the drip stops, this will set the safety valve 10% over the required pressure. The lock nut (C) should then be locked off. Paint mark to identify any tampering.

5. Repeat running with the trigger open and then

closed two or three times to ensure safety valve doesn't blow off pressure.

6. If safety valve continues to trip contact your nearest Aussie Eco-clean service centre.



PUMP PARTS WBL1114 (Scud 100)

Kit No.	Description	Pieces
12	Seal Kit Minor	15
64	Oil Seal Kit	3
70	Seal Kit Major	21
83	Full Oil Seal Kit	8
141	Valve Kit	12
166	Valve Cap Kit	12

KIT 12

KIT 70

KIT 141

KIT 83

KIT 166

KIT 64

PUMP PARTS TTL 1520 TTL 2120 (Scud 350, Scud 351)

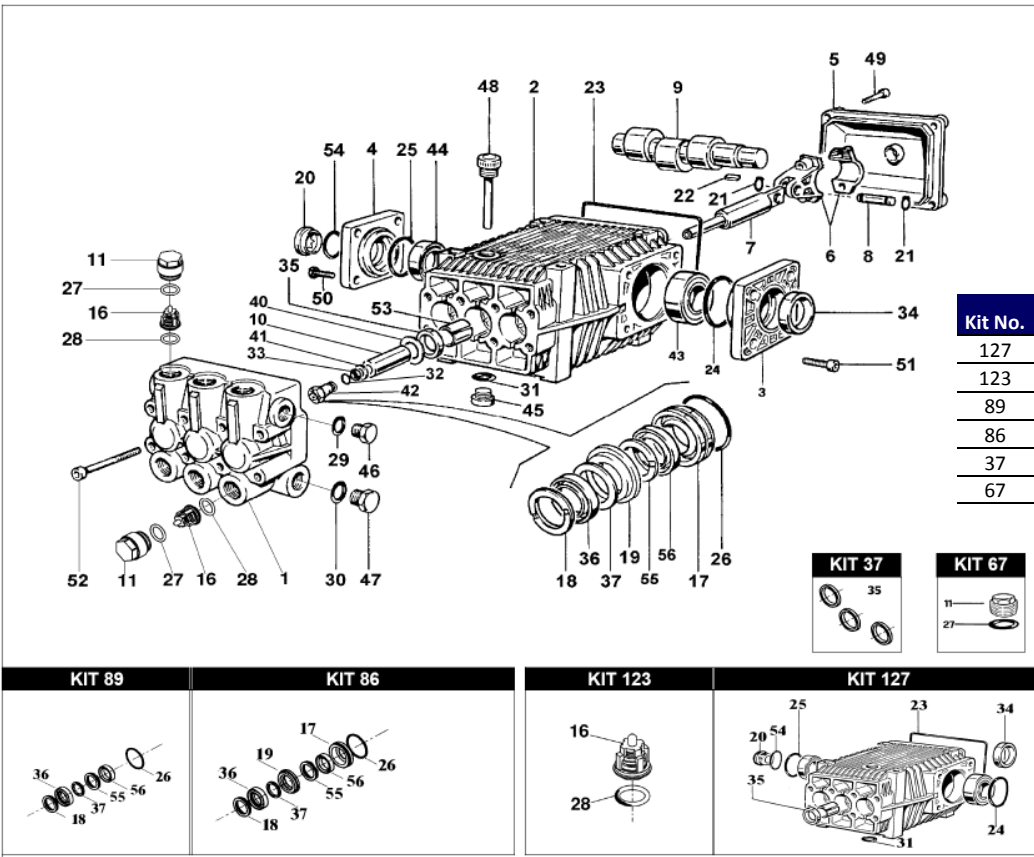

Kit No.	Description	Pieces
127	Oil Seal & Sight Glass Kit	10
123	Valve Kit	12
89	Seal Kit Minor	18
86	Seal Kit Major	24
37	Oil Seal Kit	3
67	Valve cap kit	12

PUMP PARTS TTL1330 & TTL2028 (Scud 400 & Ultra A)

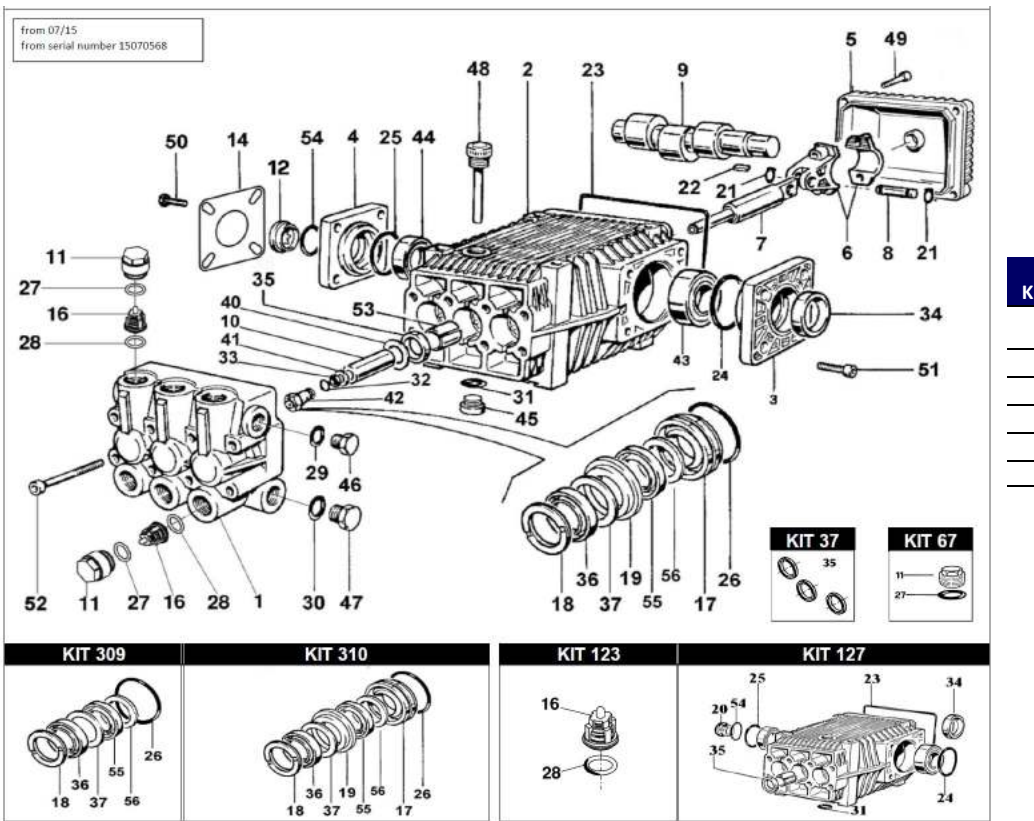

Kit No.	Description	Pieces
127	Full Oil seal & Sight Glass kit	10
123	Valve Kit	12
309	Seal Kit Minor	18
310	Seal Kit Major	24
37	Oil Seal Kit	3
67	Valve cap kit	12

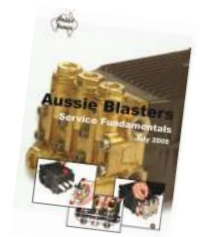

FREE pump service guide available

PUMP PARTS TTK2130 (Ultra)

Kit No.	Description	Pieces
98	Full Oil seal kit	9
123	Valve Kit	12
89	Seal Kit Minor	18
86	Seal Kit Major	24
37	Oil Seal Kit	3
67	Valve cap kit	12

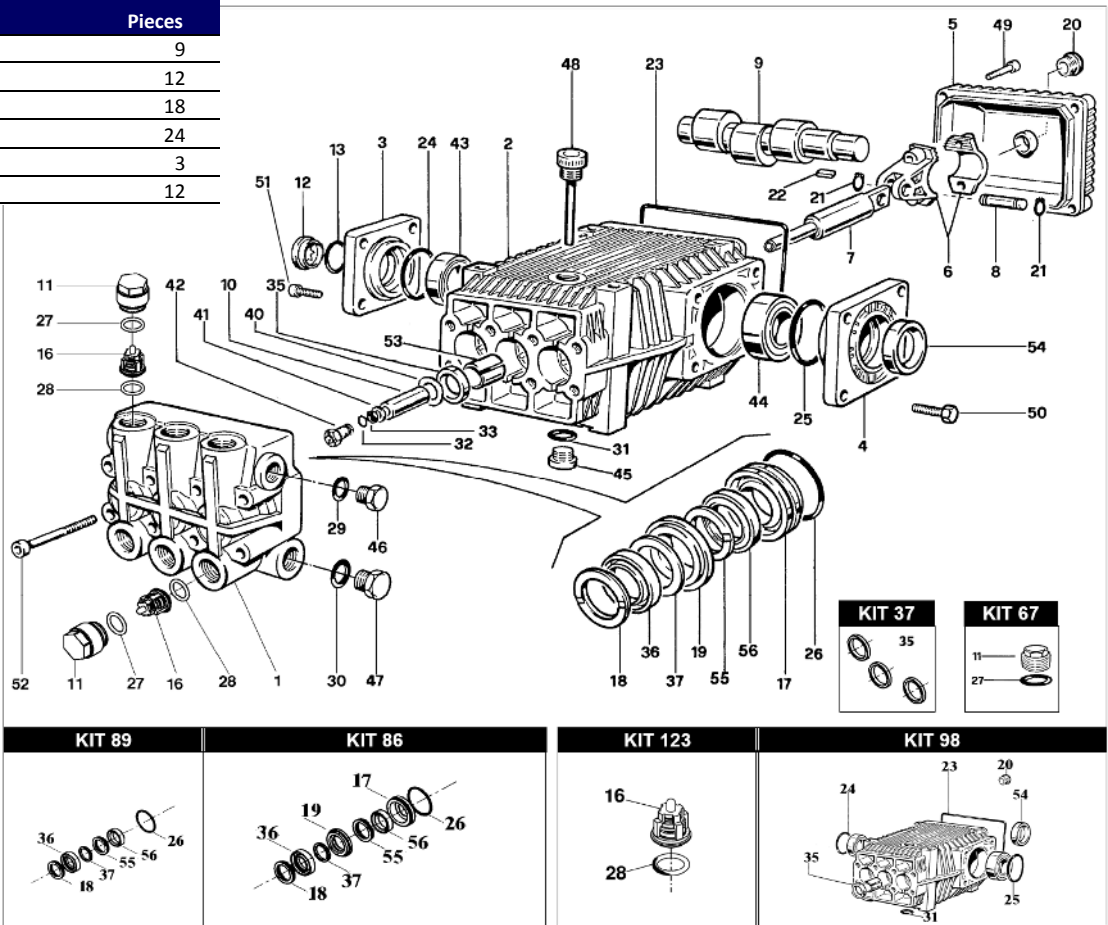

PUMP PARTS RAL 2035 Premium, RAL2535 Premium (Predator Plus)

Kit No.	Description	Pieces
123	VALVE KIT	12
271	SEAL KIT MINOR	19
270	SEAL KIT MAJOR	25
146	OIL SEAL KIT	3
67	CAP KIT	12
147	O-RING & SIGHT GLASS KIT	11

Order the right part first time ... specify the pump model number when ordering parts.

Full parts breakdowns available online ... www.aussiepumps.com.au

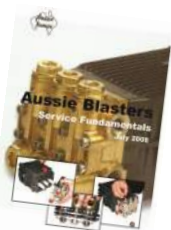

FREE pump service guide available

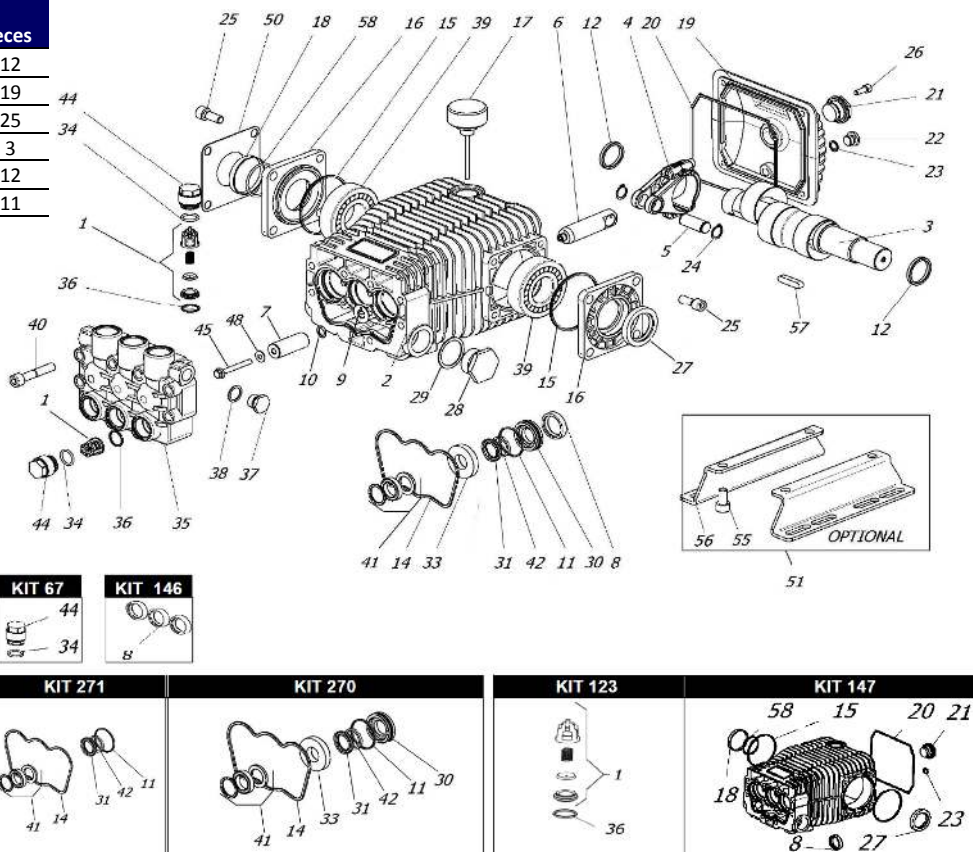

AUSSIE HIGH PRESSURE BLASTER RISK ASSESSMENT

MODELS:

In line with the National Occupation Health & Safety Commission’s requirements the data below applies to the Aussie Scud range of high pressure water blaster models:

- ◆ Scud 350
- ◆ Scud 351
- ◆ Scud 400
- ◆ Predator Plus *
- ◆ Ultra *

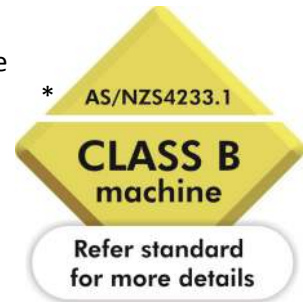

DESCRIPTION:

Engine drive high pressure cold water blasters designed for professional cleaning applications.

MATERIAL CONSTRUCTION:

Aussie Scud pressure washers are mounted on heavy duty trolley mounted frames. They consist of a quality internal combustion petrol engine driving a triplex style three piston high pressure pump. The machines are supplied with wheels for ease of portability and manoeuvrability. The machines can be supplied with hose reels and up to 45 metres of high pressure hose to increase operator convenience.

RISK RANKING METHOD:

Risk is the combination of the likelihood of a specific unwanted event and the potential consequences if it should occur.

RISK RANKING METHOD:

For each event, the appropriate probability (a letter A to E) and consequences (a number 1 to 5) is selected.

PROBABILITIES:

- A. Common or repeating occurrence.
- B. Known to occur or “it has happened”.
- C. Could occur, or “I’ve heard of it happening”.
- D. Not likely to occur.
- E. Practically impossible.

CONSEQUENCES FOR PEOPLE:

- 1. Fatality or permanent disability.
- 2. Serious lost time, injury or illness.
- 3. Moderate lost time, injury or illness.
- 4. Minor lost time, injury or illness.
- 5. No lost time.

RISK RANKING TABLE:

The consequences (loss outcomes) are combined with the probability (of those outcomes) in the risk ranking table to identify the risk rank of each loss event (e.g. a consequence of 3 with a probability of B yields a risk rank of 9).

The table yields a risk rank from 1 to 25 for each set of probabilities and consequences. A rank of 1 is the highest magnitude or risk that is a highly likely, very serious event.

A rank of 25 represents the lowest magnitude of risk, an almost impossible very low consequence event.

Controls must be taken to either eliminate or minimise the risk.

C O N S E Q U E N C E	PROBABILITY				
	A	B	C	D	E
1	1	2	4	7	11
2	3	5	8	12	16
3	6	9	13	17	20
4	10	14	18	21	23
5	15	19	22	24	25

POTENTIAL HAZARD:

Hazard	Yes/No	Risk	Risk Rating	Controls
Entanglement with hose (tripping, falling)	Yes	Personal injury of the operator or bystanders	13	<ul style="list-style-type: none"> ◆ Warning stickers ◆ hose reel option
Injury from high pressure water	Yes	Personal injury of the operator or bystanders	13	<ul style="list-style-type: none"> ◆ Warning notice on blaster ◆ Warning in Operator’s Manual, ◆ Use of safety protection clothing (Aussie Pro-operator) ◆ Use of barriers to keep bystanders away from work area
Suffocation	Yes	Fatality is the risk	7	<ul style="list-style-type: none"> ◆ Machine decal warning about operation in confined spaces ◆ Operator training in working in confined spaces
Ergonomic lifting or movement on site,	Yes	Personal injury	8	<ul style="list-style-type: none"> ◆ Machine decal warning about correct lifting procedures ◆ Operator’s Manual ◆ Staff training
High temperature (from engine muffler and other components)	Yes	Burns from muffler	15	<ul style="list-style-type: none"> ◆ Warning sticker on machine
Battery exploding if not charged correctly	Yes	Acid burns	12	<ul style="list-style-type: none"> ◆ Warning sticker on battery ◆ Wear eye & face protection when working near battery
Fire or explosion caused by refuelling engine while running	Yes	Serious injury, burns	8	<ul style="list-style-type: none"> ◆ Warning sticker on machine
Unsecured machine, moves unattended	Yes	Cause of accidents and/or injury	18	<ul style="list-style-type: none"> ◆ Warning sticker “Secure Machine during Operation” ◆ Operator’s Manual
Noise	Yes	Hearing damage	15	<ul style="list-style-type: none"> ◆ Warning sticker regarding ear muffs to be used during operation
Dislodged particles in atmosphere	Yes	Sight damage	6	<ul style="list-style-type: none"> ◆ Warning regarding wearing safety glasses.
Slipping on wet surface	Yes	Personal injury	9	<ul style="list-style-type: none"> ◆ Use of proper footwear
Contact with chemical cleaners used to clean surfaces	Yes	Skin contact could result in burns, skin irritation etc. Fumes from some chemicals may lead to respiratory problems	4	<ul style="list-style-type: none"> ◆ Chemical cleaners to only be used as a last resort when other methods have failed. ◆ Areas to be kept well ventilated. ◆ Staff to follow manufacturers’ instructions at all times for use, storage & disposal. ◆ Staff to wear the appropriate PPE ◆ Respiratory protection when required

Signed originator

Job title.....

Date Completed



WARNINGS

OVERSPEEDING

Do not operate machine at over 3200 rpm (engine speed). Over speeding can cause serious pump damage.

EXCESSIVE BYPASS

Do not run on excessive by-pass. Switch machine off within five minutes of ceasing operation as excessive by-pass can cause heat build up in pump and subsequent damage. Excessive bypass running voids warranty.

PRESSURE CLEANER DAILY CHECK LIST

- Check pump oil level
- Check engine & gearbox oil level
- Check nozzle for wear
- Check all high pressure components for leaks:
 - gun/lance
 - HP hose
 - all fittings
- Check water filter and clean regularly
- Check unloader, safety valve and thermal dump for leaks

HIGH PRESSURE SETTING

The high pressure pump is factory set to operate at its rated pressure. DO NOT ADJUST. Tampering with the pressure regulator will void warranty and can be DANGEROUS.

CHECK NOZZLE MONTHLY

If pressure drops off check nozzle for wear. Nozzles should be replaced on a regular basis (every month for machines in regular use, every three months for machines used intermittently). Using the machine with the incorrect nozzle size or worn nozzle will void warranty and can be DANGEROUS to the operator.

THREE MONTHLY REGULAR SERVICE

All professional machines need to be thoroughly serviced every three months. The service involved should include the engine manufacturer's recommendations (see separate Engine Manual) and the following;

- Change pump oil
- Check filter for foreign debris
- Check unloader, safety valve and thermal dump for leaks
- Check all HP components for leaks: Gun/lance, HP hose and all fittings
- Replace nozzles
- Check gearbox to engine key for wear, if key is worn see your local Aussie Eco Clean Service Department. NB Damage generated by worn keys is not covered by warranty.

Aussie HP Accessories ... making light work of cleaning chores



Aussie Gritblast kit ...
remove paint & rust with ease



Aussie Tele-wand ...
extend your reach to 5.5m



Aussie Turbomaster turbo lance ...
increase the effective working pressure of your blaster without loading the pump



WEAR PROTECTIVE GOGGLES & CLOTHING!



Australian Pump Industries Pty Ltd

7 Gladstone Road, Castle Hill NSW 2154

Ph: (02) 8865 3500 Fax: (02) 9894 4240

www.aussiepumps.com.au info@aussiepumps.com.au