



IMPORTANT SAFETY INFORMATION



WARNING: Read and thoroughly understand all instructions in this manual and on safety decals before assembling or operating this log splitter. Failure to do so may cause serious injury or death. Do not allow anyone to operate this log splitter who has not read this manual. As with all power equipment, a log splitter can be dangerous if assembled or used improperly. Do not operate this log splitter if you have any questions concerning safe operation. To get answers to any questions, call authorized customer service dealer.



Si no entiende ingles, se prefiere que busque alguien que interprete las instrucciones para usted.



This SAFETY ALERT SYMBOL identifies important safety messages in this manual. Failure to follow this important safety information may result in serious injury or death.

CALIFORNIA PROPOSITION 65



WARNING! Engine Exhaust, some of its constituents, and certain vehicle components contain or emit chemicals known to State of California to cause cancer and birth defects or other reproductive harm.



DANGER! This machine was built to be operated according to the safe operation practices in this manual. As with any type of power equipment, carelessness or error on the part of the operator can result in serious injury. This machine is capable of amputating hands and feet and throwing debris. Failure to observe the following safety instructions could result in serious injury or death.

The following signal words and meanings are intended to explain the levels of risk associated with this product.



DANGER

DANGER indicates a hazardous situation which, if not avoided, will result in serious injury or death.



WARNING

WARNING indicates a hazardous situation which, if not avoided, could result in serious injury or death.



CAUTION

CAUTION indicates a hazardous situation which, if not avoided, could result in minor or moderate injury.

NOTICE

NOTICE is used to address practices not related to personal injury.



IMPORTANT SAFETY INFORMATION

SAFETY DECALS

Make sure that all safety warning decals are in good condition and readable. Always replace missing or defaced decals. Contact the Authorized Service Dealer for replacement decals.

OPERATING INSTRUCTIONS		CAUTION!	WARNING!	WARNING!	WARNING!
<p>3 POSITIONS OF CONTROL HANDLE</p> <p>1. Forward position: The log splitter will operate in the forward direction. The log will be split in the forward direction.</p> <p>2. Neutral position: The log splitter will not operate. The log will not be split.</p> <p>3. Reverse position: The log splitter will operate in the reverse direction. The log will be split in the reverse direction.</p>		<p>CAUTION!</p> <ul style="list-style-type: none"> Read and understand safety and operating instructions in owner's manual completely. Failure to do so may result in serious injury or death. Always wear safety glasses, safety shoes, protective hearing devices, and light fitting gloves during operation. Set up log splitter on clear, level, dry and solid ground. Keep off slopes and slippery surfaces. Always block the wheels. Do not leave the engine running unattended. Only split wood in the direction of the grain. 	<p>WARNING!</p> <ul style="list-style-type: none"> No one under the age of 18 should operate log splitter. Only one person is permitted to load logs and operate controls. Keep bystanders, children, pets and helpers at least 25 ft. away. Always stay in operator zone specified by manufacturer during operation. Keep work area clear of split wood, debris, and other obstacles. Do not operate log splitter under the influence of alcohol or drugs. Do not stand on or reach over log splitter. 	<p>WARNING!</p> <ul style="list-style-type: none"> Keep hands, feet and all body parts away from splitting wedge, end plate, partially split wood, and moving parts. Never check for leaks with your hands during operation. High pressure fluid can escape from small holes and cause serious injury by penetrating skin which could result in blood poisoning. NEVER use your hands to dislodge a log from the wedge. This log splitter is equipped with log liftdodge, lodged log will be removed automatically when wedge is fully retracted. 	<p>WARNING!</p> <ul style="list-style-type: none"> Do not refill hydraulics oil while engine is hot or running. Do not refuel a hot or running engine. Allow the engine to cool at least 10 minutes before refueling. Never run an engine indoors or in a poorly ventilated area. Engine exhaust contains carbon monoxide, an odorless and deadly gas. Engine parts, especially the muffler, become extremely hot during operation. Do not touch.

WARNING!

To minimize risk of serious injury or death to you or others, when towing this log splitter:

- Read instruction manual for how to properly attach coupler to hitch ball and how to tow safely.
- Never attempt to move this machine over uneven or hilly terrain without a tow vehicle or adequate help.
- Use the ball of correct size.
- Do not exceed weight capacity of ball or load limits of coupler.
- Always use safety chains.
- Never exceed 45 mph.
- Avoid sharp turns and steep angles.
- Make sure of the coupler tightness each time before towing and after towing 50 miles.
- Replace damaged ball or coupler immediately.

DANGER!

- Do not use your hands to dislodge log from wedge.
- Keep hands away from wedge, end plate, partially split wood and moving parts.
- If wedge moves FORWARD when control handle released, STOP USE IMMEDIATELY! Valve may be damaged.

DANGER
KEEP HANDS AND FEET AWAY!

NOTICE

DIPSTICK

HYDRAULIC OIL

- Maintain oil level within the range specified on dipstick. Check before each use when oil is cold. DO NOT OVERFILL! Never run the log splitter without sufficient oil. The hydraulic pump could be ruined.
- Change hydraulic oil every 100 hours of use. AW32 universal Hydraulic oil is recommended. Dextron II transmission fluid can be used as a substitute should AW32 oil not be available. Do NOT mix AW32 hydraulic oil with Dextron II transmission fluid. Drain the reservoir if you wish to use Dextron II.
- Use only the filter of original equipment manufacturer's (O.E.M.).



IMPORTANT SAFETY INFORMATION

SAFETY SYMBOLS

This page depicts and describes safety symbols that may appear on this product. Read, understand, and follow all instructions on the machine before attempting to assemble and operate.

Symbol	Description
	READ THE OPERATOR'S MANUAL(S) Read, understand, and follow all instructions in the manual(s) before attempting to assemble and operate.
	FACE PROTECTION Always wear safety goggles or safety glasses with side shields, earplugs and a face shield when operating this product.
	WARNING— MOVING WEDGE Keep hands away from wedge, moving part, end plate, and partially split wood.
	BYSTANDERS Keep bystanders, helpers and children at least 25 feet away.
	SINGLE OPERATOR Only one person should operate the machine at a time. The adult who loads and stabilizes the log must be the person who operates control handle.
	WARNING— PRESSURIZED FLUID Never check for hose leaks with your hands. High pressure fluid can escape through a pin hole leak and cause serious injury by puncturing the skin and causing blood poisoning.
	WEAR GLOVES Always wear nonslip, heavy-duty protective gloves when operating this product.
	WEAR SAFETY FOOTWEAR Always wear nonslip steel-toed safety footwear when operating this product.
	WARNING— GASOLINE IS FLAMMABLE Allow the engine to cool at least ten minutes before refueling.
	WARNING— CARBON MONOXIDE Never run an engine indoors or in a poorly ventilated area. Engine exhaust contains carbon monoxide, an odorless and deadly gas.
	WARNING— HOT SURFACE Engine parts, especially the muffler, become extremely hot during operation. Allow engine and muffler to cool before touching.



WARNING! Your Responsibility—Restrict the use of this power machine to persons who read, understand and follow the warnings and instructions in this manual and on the machine.

SAVE THESE INSTRUCTIONS!



IMPORTANT SAFETY INFORMATION

TRAINING

1. Read, understand, and follow all instructions on the machine and in the manual(s) before attempting to assemble and operate. Keep this manual in a safe place for future and regular reference and for ordering replacement parts.
2. Be familiar with all controls and their proper operation. Know how to stop the machine and disengage them quickly.
3. Never allow children under 18 years of age to operate this machine. Children 16 and over should read and understand the instructions and safe operation practices in this manual and on the machine and be trained and supervised by an adult.
4. Never allow adults to operate this machine without proper instruction.
5. Many accidents occur when more than one person operates the machine. No helper is allowed to assist in stacking logs.
6. Keep bystanders, pets, and children at least 25 feet from the machine while it is in operation.
7. Never allow anyone to ride on this machine.
8. Never transport cargo on this machine.
9. Hydraulic log splitters develop high fluid pressures during operation. Fluid escaping through a pin hole opening can penetrate your skin and cause blood poisoning, gangrene, or death. Give attention to the following instructions at all times:
 - a. Do not check for leaks with your hand.
 - b. Do not operate machine with frayed, kinked, cracked, or damaged hoses, fittings, or tubing.
 - c. Stop the engine and relieve hydraulic system pressure by cycling the valve control lever from forward to reverse several times while engine is not running; returning to neutral before repairing or adjusting fittings, hoses, tubing, or other system components.
 - d. Do not adjust the pressure settings of the pump or valve.
10. Leaks can be detected by passing cardboard or wood, while wearing protective gloves and safety glasses, over the suspected area. Look for discoloration of cardboard or wood.
11. If injured by escaping fluid, see a doctor immediately. Serious infection or reaction can develop if proper medical treatment is not administered immediately.
12. Keep the operator zone and adjacent area clear for safe, secure footing.
13. If your machine is equipped with an internal combustion engine and is intended for use near any unimproved forest, brush, or grass covered land, the engine exhaust should be equipped with a spark arrestor. Make sure you comply with applicable local, state, and federal codes. Take appropriate firefighting equipment with you.



NEVER use this log splitter for any purpose other than splitting wood. It is designed for this use only. Any other use can cause serious injury or death.



IMPORTANT SAFETY INFORMATION

PREOPERATION

1. **BEFORE** operating this log splitter, make sure that you wear safety gear such as goggles or safety glasses, steel toed shoes and tight fitting gloves (without loose cuffs or draw strings). Always wear a protective hearing device when operating this log splitter.
2. **NEVER** wear loose clothing or jewelry that can be caught by moving parts of the log splitter. Keep clothing and hair away from all moving parts when operating this log splitter.
3. Check all safety guards and shields to be sure they are in the proper position. Never operate with safety guards, shields, or other protective features removed.
4. Make sure machine is on a flat, dry, solid ground before operating.
5. **ALWAYS** operate your log splitter in an open area. (Exhaust fumes contain carbon monoxide which can be deadly when inhaled.)
6. **ALWAYS** operate your log splitter in daylight or under good artificial light.
7. **ALWAYS** operate your log splitter on level ground. (Operating on a slope could cause the log splitter to roll over or logs to fall off.)
8. **ALWAYS** block wheels to prevent unintended movement.
9. **ALWAYS** lock beam in either the horizontal or vertical position.
10. **ALWAYS** keep the work area clean. Remove split wood around the log splitter immediately so that you don't stumble over it.
11. Check all nuts, bolts and hydraulic fittings are tight to be sure the equipment is in a safe working condition.
12. Both ends of the log should be cut as square as possible to help prevent the log from riding out of the splitter during operation. Do not split logs greater than 25 inches in length. Uneven logs (e.g. knotted, curved, etc.) should not be used.
13. **ALWAYS** check the oil level before you start the log splitter. See Page 30.
14. Do not allow familiarity with tools to make you careless. Remember that a careless fraction of a second is sufficient to inflict serious injury.



WARNING:



The operation of any power tool can result in foreign objects being thrown into your eyes, which can result in severe eye damage. Before beginning power tool operation, always wear safety goggles or safety glasses with side shields and, when needed, wear a full face shield and earplugs. We recommend a Wide Vision Safety Mask for use over eyeglasses or standard safety glasses with side shields. Always use eye protection which is marked to comply with ANSI Z87.1.



IMPORTANT SAFETY INFORMATION

OPERATION

1. **BEFORE** starting this machine, review the safe instructions in the manual. Failure to follow these rules may result in serious injury to the operator or bystanders.
2. **NEVER** leave this machine unattended with the engine running.
3. **DO NOT** operate machine while under the influence of alcohol, drugs, or medication.
4. **NEVER** allow anyone to operate this machine without proper instruction.
5. **ALWAYS** operate this machine with all safety equipment in place and working. Make sure all controls are operating properly for safe operation.
6. When loading a log, always place your hands on the side of the log, not on the ends, and never use your foot to help stabilize a log. Failure to do so, may result in crushed or amputated fingers, toes, hand, or foot.
7. **NEVER** use your foot, a rope or any extension device to operate the control lever on the valve. Only use hand.
8. Use only your right hand to operate the controls.
WARNING! When stabilizing log with left hand, remove your hand when the wedge just contacts the log or serious injury may occur.
9. For logs which are not cut square, the least square end of the log should be placed toward the beam and wedge, and the square end placed toward the end plate.
10. When splitting in the vertical position, stabilize the log before moving the control handle. Split as follows:
 - a. Place log on the end plate and turn until it leans against the beam and is stable.
 - b. When splitting extra-large or uneven logs, the log must be stabilized with wooden shims or split wood placed between the log and end plate or ground
11. **NEVER** place hands or feet between the log and splitting wedge during forward or reverse stroke as this could result in serious injury or death. **NEVER** attempt to load the log splitter when the ram or wedge is in motion.
12. **ALWAYS** keep fingers away from any cracks that open in the log while splitting. They can quickly close and pinch or amputate your fingers.
13. Keep your work area clean. Immediately remove split wood around the machine so you do not stumble over it.
14. **NEVER** straddle or step over the log splitter during operation.
15. **NEVER** reach or bend over the log splitter to pick up a log.
16. **NEVER try to split two logs on top of each other. NEVER try to cross split a log.**
17. **NEVER** operate your log splitter when it is in poor mechanical condition or in need of repair.
18. **NEVER** touch the muffler and other hot areas of the engine during operation. Wait until the engine cools down.
19. **NEVER** tamper with the engine to run it at excessive speeds. The maximum engine speed is preset by the manufacturer and is within safety limits. Refer to the engine owner's manual for your particular log splitter.
20. **NEVER** move the log splitter while the engine is running. Shut off the engine if you are leaving the log splitter, even for a short period of time.
21. **ALWAYS** be careful when moving or lifting the log splitter. Get assistance if it feels too heavy to move by yourself.



IMPORTANT SAFETY INFORMATION

OPERATOR ZONE

ONLY operate the log splitter from the operator zone as shown in the diagrams below. The operator has the safest and most efficient access to the control valve and the beam in this location. Operating the log splitter in another location can result in serious injury or death.

- a. Horizontal Operating Position: Stand on the control lever side of the log splitter and stabilize log as shown, if needed. See FIGURE 1.

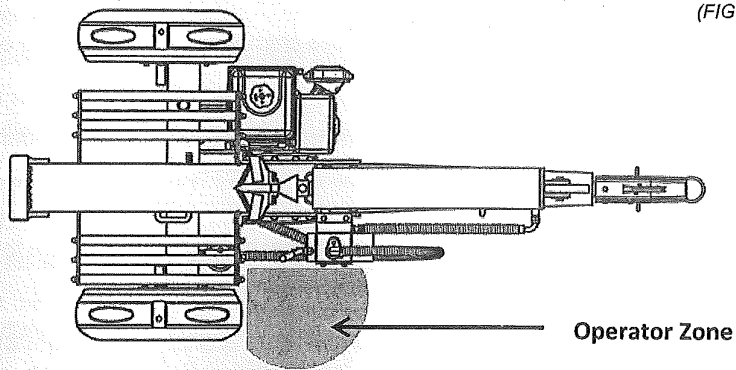

(FIGURE 1).

- b. Vertical Operating Position: Stand in front of the log splitter and stabilize log as shown, if needed. See FIGURE 2.

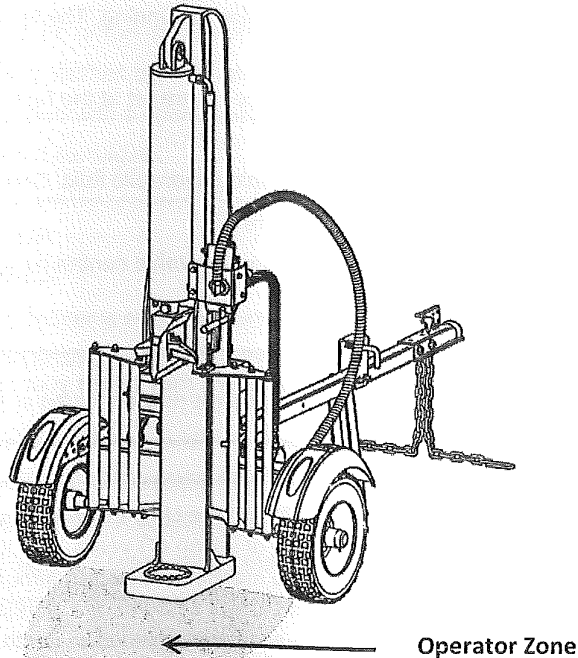

(FIGURE 2).



IMPORTANT SAFETY INFORMATION

MAINTENANCE SAFETY

1. Stop the engine, disconnect the spark plug and ground it against the engine before cleaning, or inspecting the machine. **NEVER** perform any service or repair on your log splitter without first removing the spark plug wire.
2. Stop the engine and relieve hydraulic system pressure by cycling the valve control lever from forward to reverse several times while engine is not running; returning to neutral before repairing or adjusting fittings, hoses, tubing, or other system components.
3. **ALWAYS** perform all recommended maintenance procedures before using your log splitter.
4. **ALWAYS** check the level of hydraulic oil and engine oil before operation.
5. **ALWAYS** periodically check that all nuts, bolts, screws, hydraulic fittings and hose clamps are tight to be sure equipment is in safe working condition.
6. **ALWAYS** replace all damaged or worn parts immediately with original equipment manufacturer's (O.E.M.) parts only. Use of parts which do not meet the original equipment specifications may lead to improper performance and compromise safety.
7. The hydraulic system of your log splitter requires careful inspection along with the mechanical parts. Be sure to replace frayed, kinked, cracked or otherwise damaged hydraulic hoses or hydraulic components.
8. **NEVER** check for leaks of hydraulic fluid with your hand. Fluid escaping from a small hole can be almost invisible. Escaping fluid under pressure can have sufficient force to penetrate skin causing **SERIOUS INJURY** or even **DEATH**. Leaks can be safely detected by passing a piece of cardboard over the suspected leak and looking for discoloration.
9. **NEVER** remove the cap from the hydraulic tank or reservoir while the log splitter is running. The tank could contain hot oil under pressure which could result in serious injury.
10. **NEVER** adjust the hydraulic valve. The pressure relief valve on your log splitter is preset at the factory. Only a qualified service technician should perform this adjustment.
11. **ALWAYS** seek professional medical attention immediately if injured by escaping hydraulic fluid. Serious infection or reaction can develop if proper medical treatment is not administered immediately.
12. **ALWAYS** be sure to relieve all pressure by shutting off the engine and moving the valve control handle back and forth should it become necessary to loosen or remove any hydraulic fitting.



NEVER alter your log splitter in any manner. Such alterations may cause your log splitter to be unsafe and will void the warranty.

According to the Consumer Products Safety Commission (CPSC) and the U.S. Environmental Protection Agency (EPA), this product has an Average Useful Life of seven (7) years, or 130 hours of operation. At the end of the Average Useful Life have the machine inspected annually by an authorized service dealer to ensure that all mechanical and safety systems are working properly and not worn excessively. Failure to do so can result in accidents, injuries or death.



IMPORTANT SAFETY INFORMATION

FIRE PREVENTION

1. **ALWAYS** take a Class B fire extinguisher with you when operating this log splitter in dry areas.
2. **NEVER** operate your log splitter near a flame or spark or smoke during operation. Extinguish all cigarettes, cigars, pipes, and other sources of ignition. Hydraulic oil and gasoline are flammable and can explode.
3. To avoid personal injury or property damage use extreme care in handling gasoline. Gasoline is extremely flammable and the vapors are explosive.
4. **ALWAYS** store gasoline in an approved, tightly sealed container, and keep away from heating appliances. Store the container in a cool, dry place.
5. When gasoline is spilled on yourself or your clothes which can ignite, wash your skin and change clothes immediately.
6. **NEVER** refuel the gas tank while the engine is hot or running. Allow the engine to cool before refueling.
7. **ONLY** refuel your log splitter in a clear area with no gas fumes or spilled gas. Never fuel machine indoors.
8. Never overfill the fuel tank. Fill tank to no more than 1/2 inch below bottom of filler neck to provide space for fuel expansion.
9. If gasoline is spilled out, wipe it off the engine and equipment and move machine to another area. Wait five (5) minutes before starting the engine.
10. **ALWAYS** replace the gas cap securely. Never remove gas cap while the engine is hot or running.
11. To prevent fires, clean debris and chaff from the engine and muffler areas.
12. Allow machine to cool at least ten (10) minutes before storing.
13. **ALWAYS** drain the fuel tank prior to storage to avoid the potential fire hazard.
14. Never store the machine or fuel container inside where there is an open flame, spark or pilot light as on a water heater, space heater, furnace, clothes dryer or other gas appliances.
15. If the engine is equipped with a spark arrestor muffler, clean and inspect it regularly according to manufacturer's instructions. Replace if damaged.

SPARK ARRESTOR



WARNING!

This log splitter is equipped with an internal combustion engine and should not be used on or near any unimproved forest-covered, brush-covered or grass-covered land unless the engine's exhaust system is equipped with a spark arrester meeting applicable local or state laws (if any). If a spark arrester is used, it should be maintained in effective working order by the operator. In the state of California, a spark arrester is required by law. Other states have similar laws. Federal laws apply on federal lands. A spark arrester muffler is optional and available as an accessory at your nearest engine dealer. Always check the legal requirements in your area.



IMPORTANT SAFETY INFORMATION

TOWING SAFETY

1. **NEVER** carry any cargo or wood on your log splitter.
2. **NEVER** allow anyone to sit or ride on your log splitter.
3. **ALWAYS** turn the fuel shut off valve on the engine to the "OFF" position before towing the log splitter. Failure to do so may result in flooding the engine.
4. **ALWAYS** confirm coupler tightness each time before towing and after towing 50 miles.
5. **ALWAYS** check before towing to make sure that the log splitter is correctly and securely attached to the towing vehicle and that the safety chains are secured to the hitch or bumper of the vehicle with enough slack to allow turning. Always use a Class I, 2" ball with this log splitter.
6. **NEVER** exceed weight capacity of ball or load limits of coupler. **ALWAYS** replace ball or coupler if damaged.
7. **NEVER** exceed 45 mph when towing your log splitter. Towing the log splitter at speeds higher than 45 mph could result in loss of control, damage to the equipment, or serious injury or death. Adjust towing speed for terrain and conditions.
8. **ALWAYS** be careful when backing up with your log splitter in tow. It could jackknife.
9. **ALWAYS** allow for added length of your log splitter when turning, parking, and crossing intersections and in all driving situations.
10. **ALWAYS** use safety chains when towing your log splitter.
11. Be extra cautious when towing over rough terrain, especially railroad crossings, and avoid sharp turns and steep angles when towing your log splitter.
12. Never attempt to move this machine over hilly or uneven terrain without a tow vehicle or adequate help.
13. **ALWAYS** disconnect your log splitter from the towing vehicle before operating it.
14. **ALWAYS** check all local and state regulations regarding towing, licensing, and lights before towing your log splitter. This machine should not be towed on any street, highway or public road without checking the existing federal, state, or local vehicle requirements. Any licensing or modifications such as taillights, etc., needed to comply, is the sole responsibility of the purchaser. If a "Statement of Origin" is required in your state, see your local dealer.
15. See Transporting the Log Splitter section in this manual for proper towing instructions once all federal, local, or state requirements are met.

SAVE THESE INSTRUCTIONS