

## 7. Daily Inspection and Maintenance

At the start of each work day (or 8 hour shift), the machine qualified operator must perform the Daily Inspection and maintenance (or Pre-Operation Inspection as it is sometimes referred to), as listed in the table below.

The purpose of the Daily Inspection and Maintenance is to keep the S3970RT / S3370RT / S2770RT in proper working condition and to detect signs of malfunction at the earliest possible time.

This chapter shows how to perform the inspection and maintenance required for each item in the daily inspection and maintenance table. The machine should be in the STOWED POSITION and the

Master Key Switch set to OFF before you begin this inspection.

Defective parts and/or equipment malfunctions jeopardize the safety of the operator and other personnel, and can cause damage to the machine.

### **▲ DANGER**

**The potential for an accident increases when operating a machine that is damaged or malfunctioning. Death or serious injury can result from such accidents. Do not operate a machine that is damaged or malfunctioning.**

### **■ Daily Inspection and Maintenance Table**

<b>Item</b>	<b>Service Required</b>
Rough terrain scissor interlock tests	Perform the tests to ensure the system is functioning
Fuel level	Visually inspect
Fuel filter (diesel engines only)	Visually inspect (condition)
Fuel leaks	Visually inspect (hoses and connections etc)
Engine oil	Check oil level (between dipstick lines)
Engine coolant	Check fluid level and radiator hoses
Radiator cap	Visually inspect installation)
Swinging gate	Visually inspect (installation, operation)
Wiring harnesses and connectors	Visually inspect (installation, operation)
Battery terminals	Visually inspect (no corrosion)
Battery fluid level	Visually inspect (covers plates)
Hydraulic tank cap	Visually inspect installation)
Hydraulic oil level	Check fluid level (at line on side of tank)
Hydraulic oil leaks	Visually inspect (hoses,tubes)
Tires and wheels	Visually inspect (condition)
Bolts and fasteners	Visually inspect (looseness)
Structural damage and welds	Visually inspect (welds, cracks, dents)
Guardrails	Visually inspect (condition)
Lanyard anchorages (option)	Visually inspect (condition)
Bubble level on platform	Visually inspect (condition)
Guides, rollers and slides	Visually inspect (condition)
Non slip tread grip	Visually inspect (condition)
Wrist support	Visually inspect (condition)
Operator manual	Visually inspect (that the manual is in the holder)
Placards, decals, and Operators Manual	Visually inspect (installation and condition)
<b>START THE ENGINE FROM THE GROUND CONTROL BOX</b>	
Charging system	Check condition (gauge)
Ground controls	Actuate and visually inspect for operation
Emergency lowering	Check operation (causes correct motion)
Platform controls	Actuate and visually inspect for operation
Flashing light	Visually check (operation)
RCD / ELCB (option)	Check operation
Air filter	Check condition
Safety prop	Check operation
Parking brakes	Check operation

## 7. Daily Inspection and Maintenance

---

### ■ Rough Terrain Scissor Interlock Tests

All Snorkel scissor lifts in the Snorkel 'SRT, SR and S/RT Series are fitted with a very important safety feature, a 'Stabiliser/axle/scissor Interlock' system that prevents the stabilisers being moved while the platform is elevated, and prevents the platform being raised if the rear axle is oscillated and the stabilisers are not set or the machine is tilted.

The correct operation of the Stabiliser/scissor Interlock is critical to ensure that the Scissor is operated safely and with minimum risk.

### ▲ DANGER

**To ensure the interlock system is functioning correctly, before operating the Scissor the following test must be carried out prior to operation each day, in conjunction with all other relevant daily pre-operational checks:**

#### Stabiliser locked out when platform elevated test

1. Position the machine on a firm level surface.
2. From the platform controls, start the engine and allow it to warm up.
3. Raise the platform above the elevation switch, until the engine RPM drops to idle (approx. 1.5 metres, depending on model).
4. Operate the right front stabiliser extend switch while watching the stabiliser leg for movement
5. If the stabiliser leg moves, release the switch **immediately!**  
Lower the platform fully, remove the machine from service and affix a Danger Tag warning others that the machine is not to be used. In the first instance contact the owner who will then contact the Snorkel branch or authorised agent to inspect, repair and test the machine before allowing it to be placed back into service.

If the stabiliser leg does not move, continue to step 6

6. Lower the platform to the stowed position

#### Elevation locked out when axles not stowed test

7. Park the machine such that one rear wheel is in a depression (approx. 100mm deep) such that the axle switch opens. A kerb or gutter may be sufficient

8. Raise the platform above the elevation switch, until the engine RPM drops to idle (approx. 1.5 metres, depending on model).
9. At this point, an alarm will sound and further lift or drive will be disabled.
10. If there is no alarm and/or the machine continues to allow lift **stop immediately!**  
Lower the platform fully, remove the machine from service and affix a Danger Tag warning others that the machine is not to be used. In the first instance contact the owner who will then contact the Snorkel branch or authorised agent to inspect, repair and test the machine before allowing it to be placed back into service.
11. Repeat steps 7-10 for the opposite rear wheel.
12. Lower the platform to the stowed position

#### Elevation locked out when tilted test

13. Park the machine on ground known to exceed the tilt limit specified on the serial plate.
14. Raise the platform above the elevation switch, until the engine RPM drops to idle (approx. 1.5 metres, depending on model).
15. At this point, an alarm will sound and further lift or drive will be disabled.
16. If there is no alarm and/or the machine continues to allow lift **stop immediately!**  
Lower the platform fully, remove the machine from service and affix a Danger Tag warning others that the machine is not to be used. In the first instance contact the owner who will then contact the Snorkel branch or authorised agent to inspect, repair and test the machine before allowing it to be placed back into service.
17. Lower the platform to the stowed position
18. If all steps have been followed and the Stabiliser/scissor interlock is functioning correctly, the machine can now be used in accordance with the operating instructions provided in the Operators Manual.

### Fuel Level

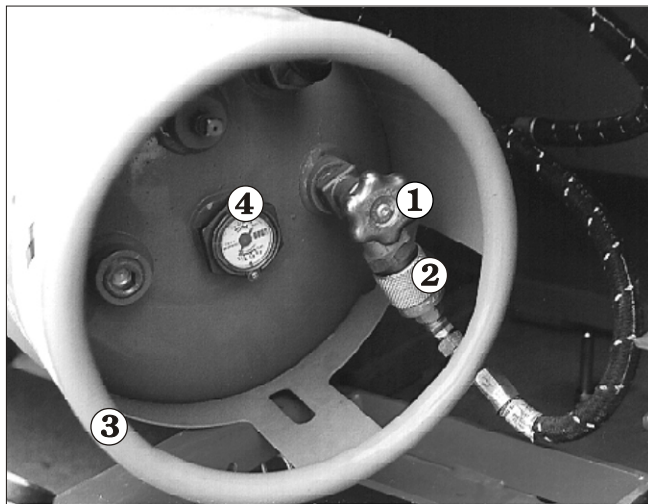

**Figure 7.1 - Fuel Level**

Remove the fuel tank cap. Visually Check to see that the gasoline or diesel tank is full. Replace the tank cap and tighten.

### (LPG - Option)

To check the fuel read the fuel meter ④, on top (see Figure 7.2).



**Figure 7.2 - LPG Fuel Tank Replacement**

To replace an LPG tank: Close the valve ① (see Figure 7.2). Manually disconnect the fuel hose at the knurled ring ②. Manually lift the tank ③ out.

### **NOTE:**

*LPG fuel tank installations are usually fitted post production and may vary from machine to machine.*

### Fuel Filter (diesel engines only)

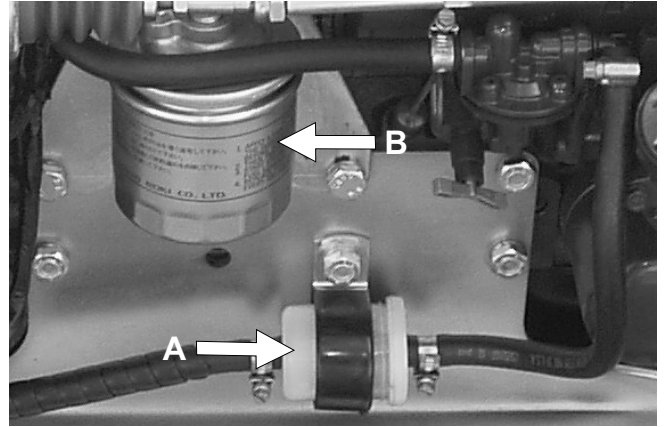

**Figure 7.3 - Fuel Filter**

The D902 has, in addition to the filter (B), a pre-filter unit (A). Visually check to see that the pre-filter is not full of contaminants and that there is no water in the bottom of the main filter (B).

### Fuel Leaks

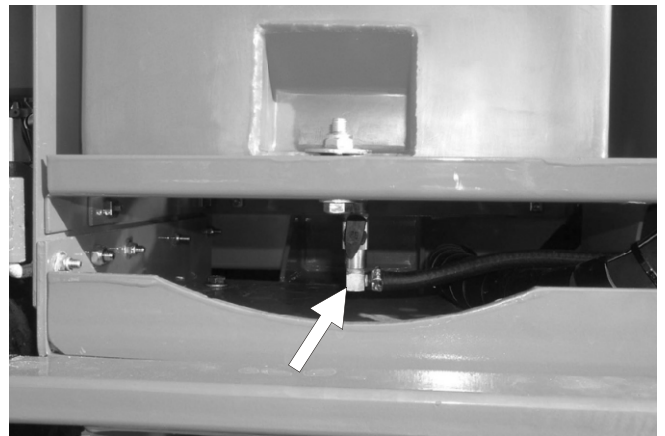

**Figure 7.4 - Fuel Leaks at Tank**

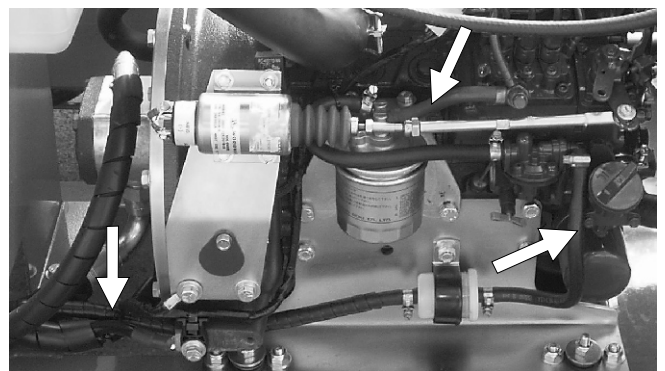

**Figure 7.5 - Fuel Leaks in Hoses & Joints**

Visually inspect the entire length of the fuel line, from the engine to the fuel tank, for leaks.



## 7. Daily Inspection and Maintenance

### ■ Engine Oil

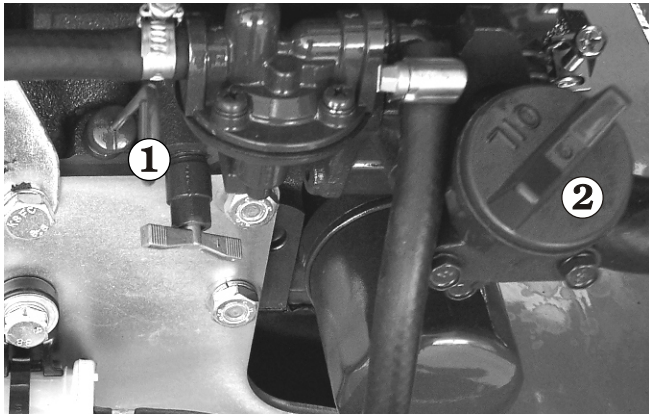

**Figure 7.6 - Engine Oil Level**

Keep the oil level between the marks on the dipstick ① (see Figure 7.6).

The distance between the top and bottom dipstick marks corresponds to about 1 qt. (one (1) liter). Add oil, if needed at the cap ② (see Figure 7.6), there is an alternative filler cap on top of the engine.

See the Specifications chapter for the correct engine oil grade and weight.

### ■ Engine Coolant

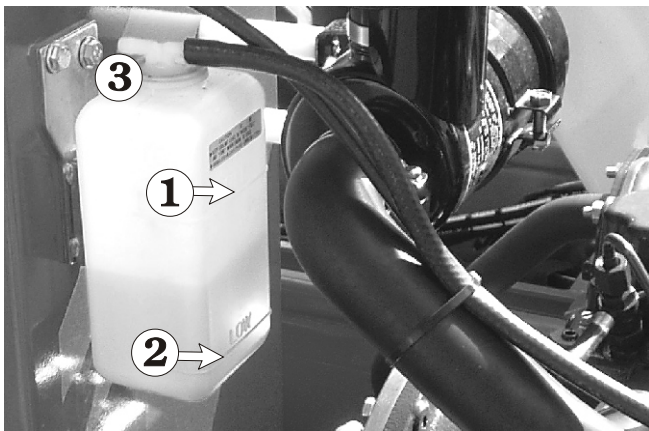

**Figure 7.7 - Engine Coolant Level**

The Kubota engine is liquid cooled. The coolant should be between the FULL level ① and the LOW level ② (see Figure 7.7).

The coolant is half water and half ethylene glycol.

To add coolant:

Turn the engine OFF at the ground control box KEY SWITCH. Remove the cap ③ (see Figure 7.7) from the coolant reservoir. Add coolant and replace cap.

### ■ Radiator Cap

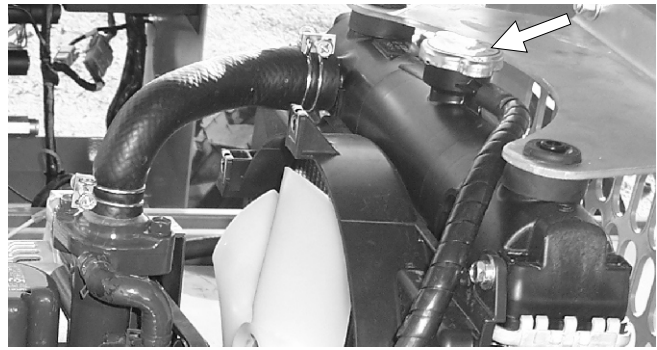

**Figure 7.8 - Radiator Cap**

Visually check to see that the cap is in place and tight.

### ■ Swinging Gate

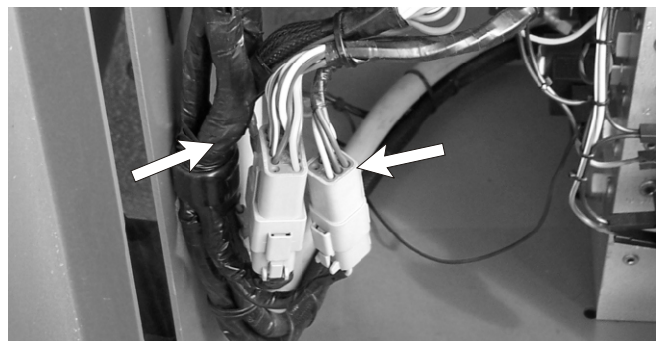

**Figure 7.9 - Swinging Gate**

Inspect the gate to see that it swings freely, latches securely, and is not deformed in any way.

### ■ Wiring Harnesses and Connectors

Inspect all the wiring harnesses, on the machine, for loose connections, broken wires, and frayed insulation.



**Figure 7.10 - Wiring Harnesses and Connectors**

## 7. Daily Inspection and Maintenance



**Figure 7.11 - Wiring Harness in the Scissor Stack**

Pay particular attention to the wiring harnesses that are attached to the scissor stack. Note that the wire harness runs with the main hose bundle.

### ■ Battery Terminals



**Figure 7.12 - Battery Terminals**

Battery terminals should be clean and free of corrosion and the battery leads firmly attached.

### □ Battery Fluid Level

#### ▲ DANGER

**Batteries emit hydrogen and oxygen, elements that can combine explosively. Death or serious injury can result from a chemical explosion.**

**DO NOT** smoke or permit open flames or sparks when checking batteries.

#### **Note**

*Units manufactured in New Zealand are typically fitted with a "maintenance free" battery.*

If your unit is not fitted with such a battery you will need to do the following.

Remove the caps from the battery and visually check to see that the battery fluid is 1/4 (6 mm) below the bottom of the filler neck inside each hole

### ■ Hydraulic Oil Tank

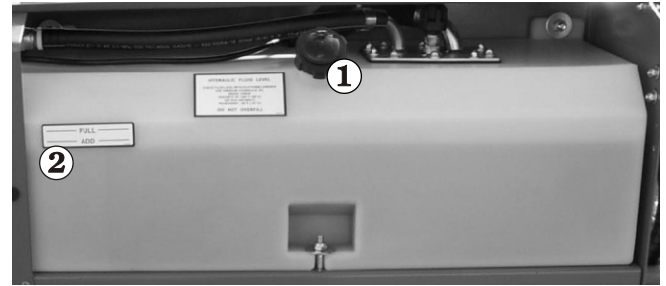

**Figure 7.13 - Hydraulic Oil Tank**

### □ Hydraulic tank cap

Check to see that the cap ① is in place and is tight (see Figure 7.13).

### □ Hydraulic oil level

To check the hydraulic oil level:

Completely lower the platform. The hydraulic oil level should be at the full level according to the gauge ② (see Figure 7.13). If necessary, add hydraulic oil at the Hydraulic oil tank cap. See the Specifications chapter for type and grade of hydraulic oil.

### ■ Hydraulic Oil Leaks

#### ▲ DANGER

**Leaking hydraulic oil can cause burns, fires, falls (slipping), cuts, and puncture wounds (if under high pressure). Do not tolerate hydraulic oil leaks. They are dangerous.**

Do not search for leaks with your hand, use a piece of cardboard or wood. Hydraulic oil leaks are easily visible and can show up anywhere. Visually inspect the entire machine for hydraulic oil. Check the ground under the machine for leaked oil.

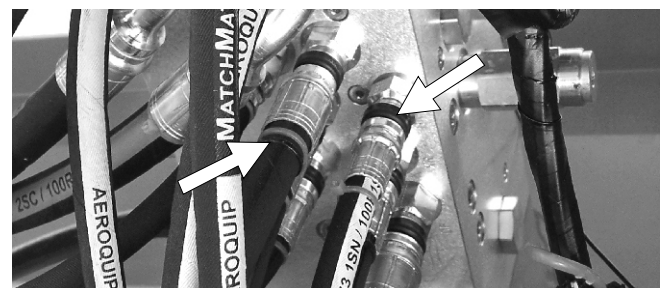

**Figure 7.14 - Check Fittings at Valve**



## 7. Daily Inspection and Maintenance

Check all fittings and hoses for leaks. Inspect hoses for signs of damage from chaffing or rubbing against protrusions on the chassis or scissor stack.



**Figure 7.15 - Check Hydraulic Cylinders**

Pay particular attention to the cylinders, check to see that there is no oil leaking from the seal, also check all hoses that run to the cylinders.

Have a qualified trained maintenance person repair all hydraulic fluid leaks before you operate the machine.

### ■ Tires and Wheels

S3970RT / S3370RT / S2770RT tires are foam filled. Punctures of the type caused by bolts, screws, or nails are not a problem.

Look for large holes or long cuts completely through the tire body: holes or cuts where foam is being forced or eroded out of the tire.

Also look for large imbedded objects, such as angle iron, that can rip a tire body open under some conditions.

### ■ Bolts and Fasteners

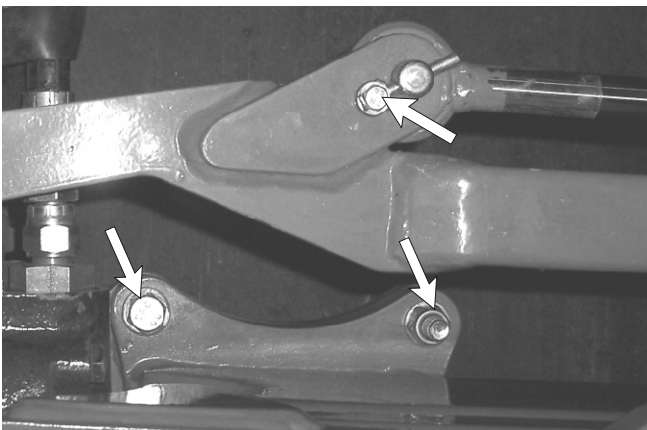

**Figure 7.16 - Bolts and Fasteners**

Visually inspect all fasteners to see that none are missing or obviously loose.

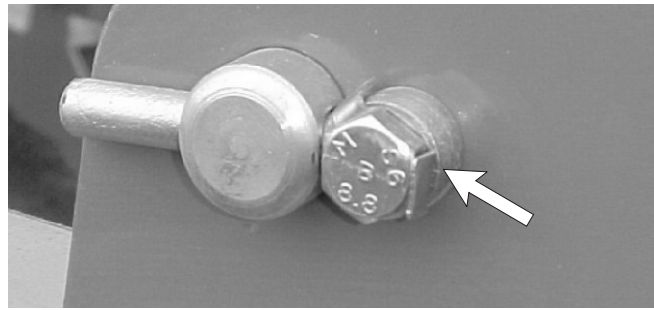

**Figure 7.17 - Critical Pin Retainer Bolts**

Critical pin retainer bolts have lock tab washers fitted, they should all be present and not damaged in any way.

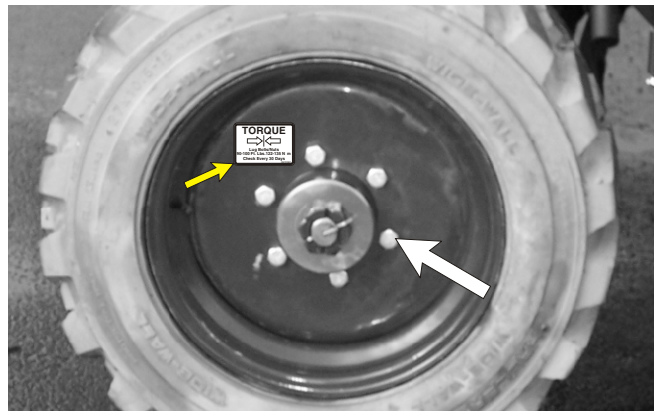

**Figure 7.18 - Wheel Nuts**

Pay particular attention to all of the wheel nuts. None should be visibly loose, missing, or deformed.

A decal is attached to each wheel rim giving the correct torque settings for the wheel nuts, see yellow arrow.

### ▲ IMPORTANT

The correct torque setting for the S3970RT / S3370RT / S2770RT wheel nuts is 90 - 100 lb ft or 122 - 135 Nm. Do not tighten beyond these settings.

### ▲ CAUTION

Do not over tighten wheel nuts. Over tightened wheel nuts can damage or deform the wheel rim. This could lead to stability problems.

### ■ Structural Damage & Welds



**Figure 7.19 - Structural Damage and Welds**

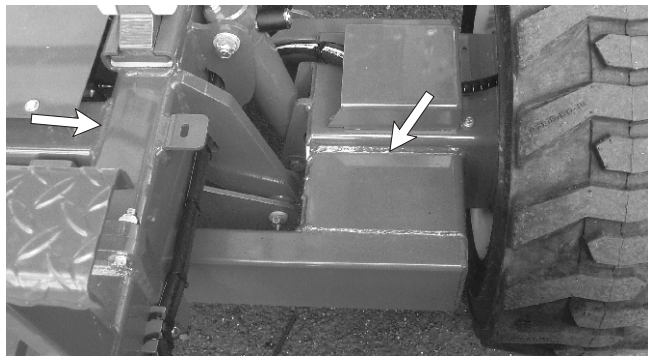

**Figure 7.20 - Structural Damage and Welds**

Visually inspect all welds for cracks, all structural members for deformity, and all sheet metal for dents that could interfere with machine operation.

### ■ Guardrails



**Figure 7.21 - Guardrails**

Pay particular attention to the guardrails. Make sure the guardrails are properly installed, that all the fasteners are in place, and that the swinging gate is in place and works properly.

### ■ Bubble Level

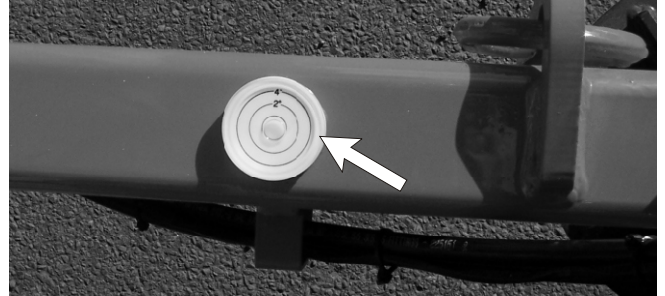

**Figure 7.22 - Bubble Level**

Visually check to see that the bubble level is not damaged, that it is full of fluid, that the bubble does not exceed the diameter of the center black circle, and the surface on which the bubble level is mounted is not deformed or bent out of level.

### ■ Guides, rollers, and slides

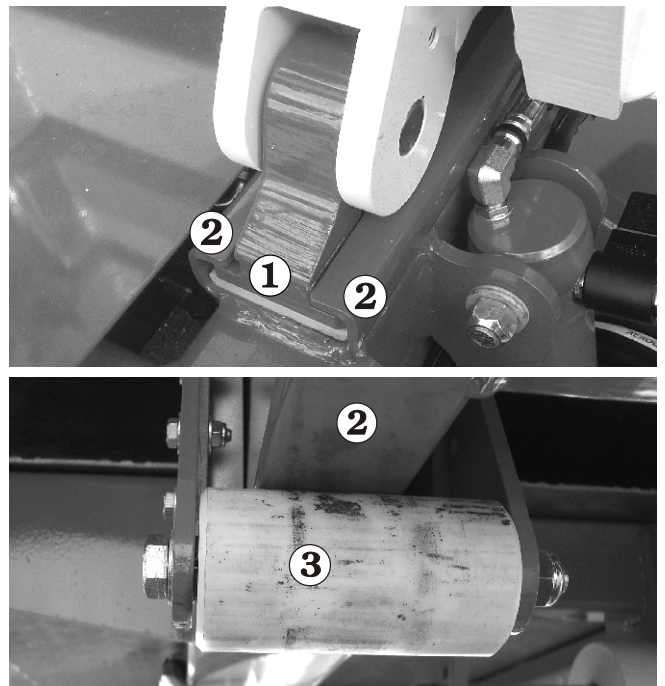

**Figure 7.23 - Guides, Rollers and Slides**

Visually check slides ① and rollers ③ for wear or damage. Be sure that the guides ② are free of debris and allow the slides and rollers to move smoothly.



## 7. Daily Inspection and Maintenance

### ■ Charging System



**Figure 7.24 - Ammeter Gauge**

With the engine idling, the needle in the AMPS gauge should not be to the left of 0" (left of 0" is discharging).

#### **NOTE**

*Leave the engine running for the next step*

### ■ Ground Controls

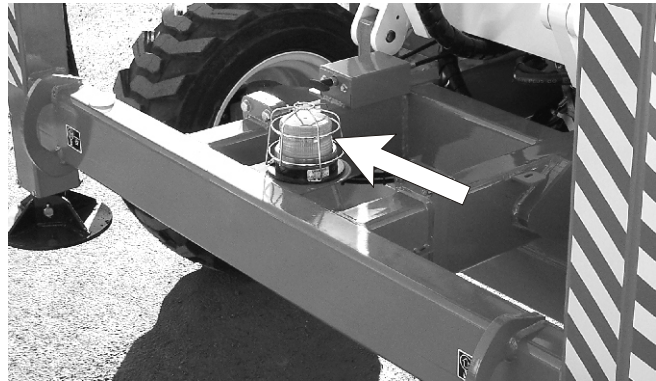

**Figure 7.26 - Ground Controls**

Check the Platform Lift/Lower switch ① (see Figure 7.26) to see that it is functioning properly by holding the switch up to rise platform and pushing the switch down to lower the platform.

Pay particular attention to the Emergency Stop switch ② (see Figure 7.26) to see that it turns the S3970RT / S3370RT / S2770RT engine off when struck.

### ■ Flashing Light



**Figure 7.27 - Flashing Light**

Check to see that the light flashes approximately once a second when the S3970RT / S3370RT / S2770RT engine is running.

### ■ Platform Controls

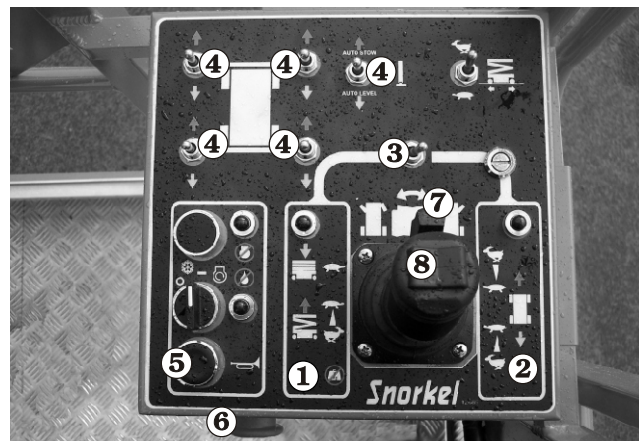

**Figure 7.28 - Platform Controls**

Check all of the lift , drive ②, steer ③, and stabiliser ④ functions from the platform control box to see that they cause the S3970RT / S3370RT / S2770RT to move the way it should (see Figure 7.28). (for correct operating procedures see the Operation chapter ).

Listen for the lowering alarm while the platform is going down. Listen for the motion alarm while the S3970RT / S3370RT / S2770RT is being driven forward. Listen for the back-up alarm while the S3970RT / S3370RT / S2770RT is backing up.

Press the operator horn ⑤ (see Figure 7.28) to see that it works.

Pay particular attention to the **Emergency Stop** switch ⑥ to see that it turns the engine off when struck (see Figure 7.28).



Pay particular attention to the **Safety Control 7** to see that it deactivates the **Joystick Controller 8** when the safety control 7 is released (see Figure 7.28).

### Emergency Lowering

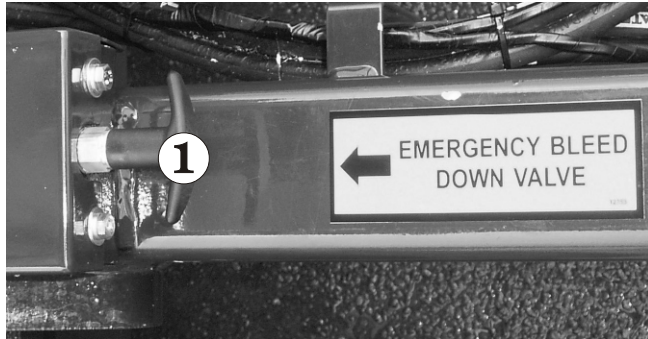
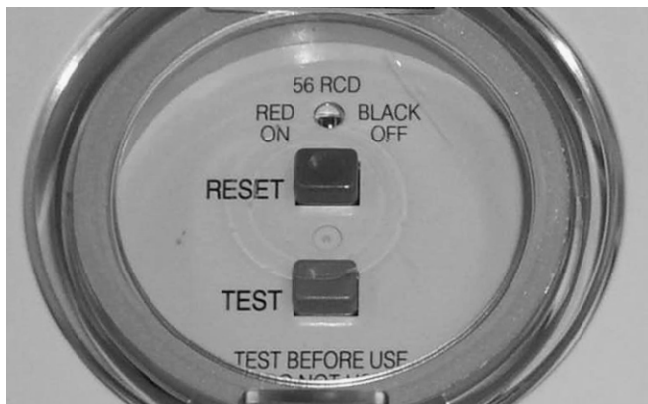

**Figure 7.29 - Emergency Lowering**

To check the emergency lowering: Raise the platform and turn the engine OFF at the ground control box KEY SWITCH.

Operate the emergency lower by pulling on the cable 1 (see Figure 7.29) located at the front of the chassis. When the platform is fully lowered release the cable.

### RCD / ELCB (Option)



**Figure 7.30 - RCD / ELCB**

The RCD (Residual Current Device) is located at the ground and will protect against short circuits to earth. When there is a short circuit the RCD will shut down the 230v AC power to the platform outlet.

To reset the outlet disconnect the power tool lead from the platform box and reset the RCD at the ground.

If the problem persists call a trained service technician.

### Safety prop



**Figure 7.31 - Safety Prop**

Inspect the safety prop(s) to see that it is present and moves freely.

### Lanyard Anchorages (Option)

Check all four (4) lanyard anchorages on the floor of the platform to see that they are present, not deformed, that they move freely, and that they are securely attached to the platform.

### Non-Slip Tread Grip

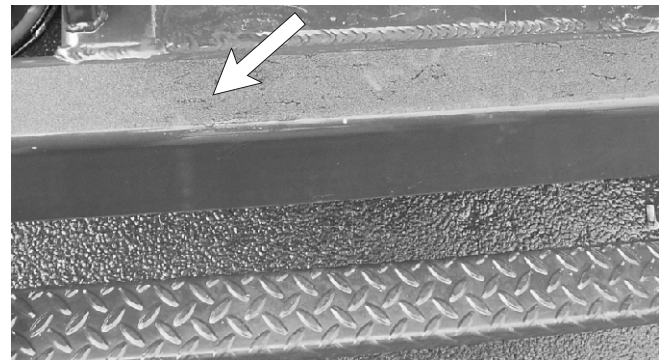

**Figure 7.32 - Non-Slip Grip Strip**

Check that the non-slip protective strip is in place and in good condition

## 7. Daily Inspection and Maintenance

---

### ■ Wrist Support

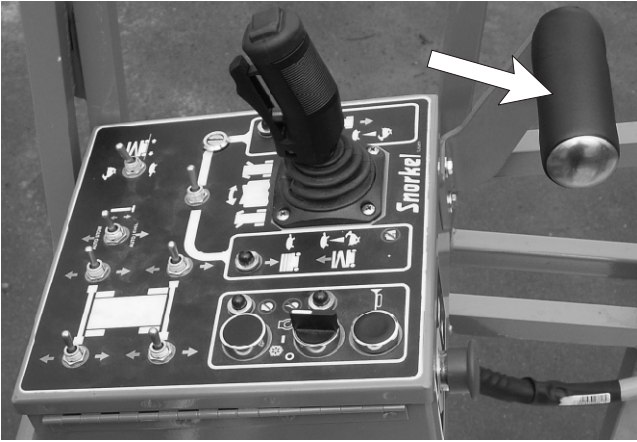

**Figure 7.33 - Wrist Support**

Check the condition of the rubber on the upper control box wrist support. Replace it if it is worn or damaged.

### ■ Operator Manual



**Figure 7.34 - Operator Manual Holder**

Check that the operation manual is in the holder.

## 7. Daily Inspection and Maintenance

---



## 7. Daily Inspection and Maintenance

### ■ Placards and Decals

Look to see that all placards and decals are in place and legible. Replace any missing or illegible placards or decals before placing the S3970RT / S3370RT / S2770RT into service for the daily work shift.

Decal and placard kits for the S3970RT / S3370RT / S2770RT are available from Snorkel dealers.

### Standard placards and decals

- See page 7 - 11 for the following items:

No	Part No	Description	Req
1	1843	Decal - Warning, N.Z. only	1
	9428	Decal - Electrical hazard, Australia only	1
2	9208	Decal - Water	1
3	96924-9	Decal - Warning stripes yellow/black	4m
4	12833-8	Decal - Serial number	1
5	9751	Decal - N.Z. made	1
6	13471-10	Decal - S3970RT	2
	511081-000	Decal - S3370RT	2
	511079-000	Decal - S2770RT	2
7	12699-4	Decal - Rated load, S3970RT	1
	12699	Decal - Rated load, S3370RT	1
	11346-1	Decal - Rated load, S2770RT	1
8	0073298	Decal - Foam tyres	1
9	451986	Decal - Interlocks	2
10	476706	Decal - Explosive fumes	2
11	12574	Decal - Danger with alarm	1
12	511101-000	Decal - Snorkel logo	5
13	560240	Decal - Lower control box	1
14	12689	Decal - Upper control box	1
15	560272	Decal - Emergency stop upper box	1
16	605726	Decal - Diesel fuel	1
17	12753	Decal - Emergency bleed down	1
18	12814	Decal - Hydraulic fluid	1
19	58365-6	Decal - Safety prop	1
20	96924-9	Decal - Warning stripes yellow/black	
21	300699	Decal - Operators checklist	1

No	Part No	Description	Req
22	0323897	Decal - Must not operate	1
23	621486	Decal - Forklift	4
24	302950	Decal - Hydraulic oil level	1
25	300700	Decal - Shearing hazard	1
26	13370 Rev B	Decal - Emergency operation, emergency lowering & emergency pushing	1
27	0083427	Decal - Lifting/tie down	4
28	12815-4	Decal - Hydraulic circuit, S3970RT / S3370RT / S2770RT	1
29	12815-2	Decal - Electrical circuit, S3970RT / S3370RT / S2770RT	1
30	562426	Decal - Operators manual enclosed	1
31	0372061	Decal - Torque wheel nuts	4
32	511067-000	Decal - www.snorkellift.com	2
33	501453-000	Decal - Foot crush hazard	4

# 7. Daily Inspection and Maintenance

☐ Inspection drawing

