

SELWOOD D150R CC / PERKINS 403D-15

Operating & Service Manual

The products of Selwood Limited, are designed, developed and produced in the company's Chandler's Ford factory. Many features are covered by worldwide patents. Product names such as Spate, Simplite and Seltorque, are registered trademarks.

As all products are subject to continuous development, the company reserves the right to alter the specifications and information given in this manual without prior notice.

Whilst every care has been taken in the preparation of this publication the information it contains must not be regarded as binding.

Amendments to this publication will only be issued to cover those design changes, which fundamentally alter the build or operation and servicing procedures. They will be distributed through the company's dealers and agencies.

Your attention is drawn to the following symbols used throughout this manual:-



CAUTION

This caution symbol draws attention to special instructions or procedures that, if not correctly followed, may result in damage to, or destruction of equipment.



WARNING

This warning symbol draws attention to special instructions or procedures that, if not strictly observed, may result in personal injury.



WARNING

A WARNING SYMBOL WITH THIS TYPE OF TEXT DRAWS ATTENTION TO SPECIAL INSTRUCTIONS OR PROCEDURES WHICH, IF NOT STRICTLY OBSERVED MAY RESULT IN SEVERE PERSONAL INJURY, OR LOSS OF LIFE.

Additional copies of this manual are available from Selwood Pt No 1511076000

Published by Selwood Limited
© Selwood Limited Nov 2012

Instructions for Ordering Replacement Parts

1. Always quote the pump serial number located on the plate fastened to the bearing and air pump mechanism housing.
2. Always quote the part number(s) (ten digits) of the component(s), NOT the item number(s).
3. Always quote the description of the component(s).

Items usually supplied together as sub-assemblies will have the sub-assembly part number printed at the bottom of the relevant page.

HEALTH AND SAFETY AT WORK 1974

As manufacturers of pumps and associated equipment we wish to inform you that, in compliance with Section 6 of the Act, safety precautions should be taken with our products.

We take every care to ensure as is reasonably practicable that our products are safe and without risk to health when properly used. Nevertheless, appropriate health and safety precautions must be taken, and in particular you are requested to have special regard to the operational and safety requirements leaflet P769, which accompanies each pump on despatch from our premises.



Our products also conform to the EEC Machinery Safety Directive and carry the C.E. mark.

CALIFORNIA USA PROPOSITION 65 WARNING



Diesel engine exhaust and some of its constituents are known to the State of California to cause cancer, birth defects, and other reproductive harm.

WARNING

Pumps and engines may be fitted with seals or 'O' rings manufactured from **VITON** or similar material.



When temperatures reach 400°C (720°F) a corrosive acid is produced, which cannot be removed from the skin.

If signs of material decomposition are evident, or if in doubt, **always wear disposable heavy-duty gloves.**

SAFETY PRECAUTIONS



WARNING

ALL ITEMS IN THIS SECTION, IF NOT STRICTLY OBSERVED, COULD RESULT IN SEVERE PERSONAL INJURY OR LOSS OF LIFE.

1. Use only lifting equipment of suitable capacity for the size and weight of the equipment being lifted
2. The equipment must always be lifted using safe working practices and in accordance with any local and national guidelines or statutes. It is intended for guidance only. If in doubt, consult Selwood Pumps or a local lifting expert.
3. Whilst lifting the unit keep personnel well away and **never** allow people underneath.
4. Personnel working on the pump must always wear clean, correctly fitting clothing and safety footwear. Clothing impregnated with oil or fuel can constitute a health hazard through prolonged contact with the skin and may also constitute a fire hazard.
5. Check the type of liquid that the pump has been employed on before working on them. Residues could be hazardous to your health. If in doubt, flush thoroughly with clean water before commencing work.
6. Rotating equipment presents a hazard in itself. Alert surrounding personnel before starting and post notifications whilst in operation.
7. Moving parts are guarded to protect you. Guards removed for maintenance must be replaced before starting the pump.
8. Never insert anything into the pump body whilst the pump is running and the suction or delivery hoses are disconnected.
9. Use all flange bolt holes and ensure the correct bolt size and quality is utilised when connecting suction and delivery hoses.
10. Collapsible hoses must never be used on the suction side of the pump.
11. Keep the hose end suction area free from debris. Although the pump can handle solids up to the size indicated in the Technical Data section of this manual, larger or irregular solids may cause blockage with damage to pump components.
12. Always allow adequate ventilation for the pump driver. Diesel engines require air for both combustion and cooling. This air must never be allowed to re-circulate.
13. Be aware of burn and fire risks from items such as exhaust pipes and silencers. Never place flammable items around the unit.
14. Liquid pressure may still be present even after shutdown of the pump. Particular attention should be paid to delivery lines that are long, or rise through any height, as these can contain large volumes of liquid. These lines must be isolated and drained down before commencing work. Sudden release of this liquid can cause serious injury to an operator either directly or indirectly through the rotational motion it can induce.



15. **WARNING!** Delivery hose and any associated pipe work should be capable of withstanding the maximum system operating pressure. Selwood recommend the minimum pressure rating of 10Bar hose. Suction hose should be of the non-collapsible variety.



16. **WARNING! The pump should only be operated within the speed and pressure limits detailed in Section 2 of this manual.**

1. If there is a danger of freezing, the fluid, normally retained within the pump between operating cycles, should be drained off through the drain tap provided.



2. **WARNING!** Never start or run the pump against a closed delivery valve (except the pump non return valve). Failure to comply may result in damage to the unit or personal injury.



3. **WARNING!** Noise level at operator position (Start Panel) is over 80 dB(A). Hearing protection must be worn at all times within the canopy when the unit is running. Failure to comply may result in hearing damage or loss.

SELWOOD D150R CC / PERKINS 403D-15

CONTENTS

Title	Page
Safety Precautions	2
1 GENERAL INFORMATION	4
1.1 Installation	4
1.2 Operation	4
1.3 Maintenance	4
1.4 I.C. Engines	4
1.5 Fitting Instructions for Centaflex Couplings (Diesel Engines)	5
1.5.1 Preparation of the Centaflex Coupling for Pump Removal.	5
1.5.2 Centaflex Coupling Assembly Sequence ...	5
1.5.3 Replacement of the Steel Hub and Rubber Element	5
1.6 Selwood D150R CC Data	6
2 ROUTINE MAINTENANCE	6
3 LUBRICATION AND FASTENING TORQUES	7
3.1 Pump Lubrication	7
3.1.1 Commissioning Period	7
3.1.2 After Commissioning Period	7
3.1.3 Main Pump Bearings	7
3.2 Fastening Torques	8
4 CONDITIONS OF WARRANTY	8
5 MAJOR SERVICING	9
5.1 Air Pump Maintenance	9
5.1.1 Delivery and Suction Valves	9
5.1.2 Actuator Valve	9
5.1.3 Actuator Seal	9
5.1.4 Actuator Neck Seal	10
5.1.5 Pedestal bush and Seals.....	10
5.1.6 Air Pump Mechanism	11
5.1.7 Eccentric Shaft	11
5.1.8 Lip Seal	12
5.1.9 Roller Bearings.....	12
5.1.10 Con Rod and Drive Rod.....	12
5.1.11 Drive Belt	12
5.1.12 Drive Belt Tension.....	12
5.1.13 Air Pump Assembly	12
5.2 Separator Maintenance	13
5.2.1 Float	13
5.2.2 Peel Valve.....	13
5.2.3 Deposits of Solids	14
5.3 Impeller, Mechanical Seal, Wear Plate and Delivery Valve Maintenance	14
5.3.1 Impeller	14
5.3.2 Setting Impeller Clearances	15
5.3.3 Mechanical Seal.....	15
5.3.4 Front Wear Plate.....	16
5.3.5 Rear Wear Plate.....	16
5.3.6 Delivery Valve.....	17
5.4 Maintenance of Lip seals, Headland V Seal, Bearings and Main shaft.	18
5.4.1 Lip Seals	18
5.4.2 Headland V Seal	18
5.4.3 Bearings.....	19
5.4.4 Main Shaft.....	20
5.5 Chassis Maintenance	20
5.6 Canopy - Canopy Removal	20
5.7 Canopy - Fuel Tank Removal.....	20
5.8 Canopy – Fuel Tank Refitting	21
5.9 Pump removal	21
5.10 Engine removal	21
5.11 Engine & pump re-fitment.....	21
5.12 Canopy – Canopy Refitting	21
6 WORKSHOP TOOLS	22
6.1 Care of Servicing Tools	22
7 USE OF SERVICE TOOLS	22
7.1 Fitting of Actuator Neck Seal	22
7.2 Removal of Mechanical Seal Stationary Seat and Joint Ring	22
7.3 Removal of Linear Bearing Seal Assembly	23
7.4 Fit Air Pump Pedestal with Seals to Air Pump Bearing Housing	23
7.5 Remove Pedestal Bush.....	23
7.6 Fit New Pedestal Bush	23
7.7 Impeller Spacer Removal	24
7.8 Fit New Mechanical Seal Stationary Seat and Joint Ring	24
8 FAULT FINDING GUIDE	25
9 PARTS LIST	29
9.1 Air Pump Drive Assembly 1502021000	29
9.2 Air Pump Parts 1502021000	31
9.3 Delivery Valve Parts 1589107000	33
9.4 Bearing Housing Assembly 1509295000	35
9.5 Separator Parts 1589162000	37
9.6 Bearing Housing and Pedestal Assembly	39
9.7 D150 Pump Unit	41
9.8 D150 Close Coupled Pump Unit 1511056000	43
9.9 D150R CC CORE BUILD 1511039000	45
10 Plastic fuel tank assembly 1502478000	47
11 D150R CC / PERKINS 403D-15 Rapid Response 1511038000	49
12 2 WHEEL TRAILER ASSY 9729-00022	53
13 WIRING DIAGRAMS	56
13.1 Fast Tow Trailer Lighting Circuit.....	56

1 GENERAL INFORMATION

1.1 Installation

1. The pump unit and its associated base plate or trolley mounting should be positioned on a firm horizontal platform, and in the case of portable units restrained from accidental movement.
2. If the pump is fitted with push-on type suction and delivery spigots the hoses must be firmly secured on these spigots with heavy duty clamps or clips capable of withstanding the system operating pressure.
3. The integrity of the hose clamping arrangements should be checked at regular daily intervals in the case of static installations or whenever the pump is repositioned in the case of portable units.
4. Similar precautions should be taken with clamps securing multiple lengths of hose on installation where long delivery and suction lines are involved.
5. Delivery hose and any associated pipe work should be capable of withstanding the maximum system operating pressure. Suction hose should be of the non-collapsible variety.

1.2 Operation

1. The pump should only be operated within the speed and pressure limits detailed in this operating handbook for the model in question.
2. If there is a danger of freezing, the fluid normally retained within the pump between operating cycles should be drained off through the drain taps provided.
3. Where protective caps are used to prevent damage to the suction and delivery spigots during storage or in transit they must be removed before the pump is started up.

1.3 Maintenance

1. Inspection and maintenance procedures are detailed in the operating and servicing manual for the model in question.
2. Replacement parts. Only the manufacturers or factory-approved components should be used as replacement parts and where necessary they should be fitted with the assistance of the special purpose tools indicated in the operating and servicing manual.
3. All maintenance work must be carried out with the pump and engine/motor stationary.

1.4 I.C. Engines

1. Where I.C. engines are used to power the pump they have been mounted in accordance with the engine manufacturers recommendations and adequate guarding provided between the pump and engine.

2. **Exhaust and Exhaust Pipes.** If there is a risk of accidental contact by operators, the exhaust system should be lagged or screened and the outlet directed away from operators or other persons likely to be nearby. Direct contact with flammable materials of all types must be avoided. The importance of adequate ventilation to ensure removal of exhaust fumes when engines are operated in enclosed or covered accommodation cannot be over-stressed. Engines should not be run in hazardous explosive atmospheres.
3. **Access and Operation.** Ensure that the operator can start, control and stop the engine easily by making all controls readily accessible. Fit remote controls if access is difficult. Follow the instructions laid down in the Engine Manufacturer's Operators Handbook for starting, operating and stopping procedures.
4. **Fuel.** In addition to the fire hazard associated with fuel and lubricating oils, preventative action is necessary with respect to leakage, contamination and bodily contact.

1.5 Fitting Instructions for Centaflex Couplings (Diesel Engines)

IMPORTANT NOTES – OBSERVE STRICTLY:

The most likely component to require replacement will be the rubber element and servicing of this item is explained in Section 1.5.3 below.

The coupling assembly consists of a central steel hub whose outside diameter locates within a bore of a rubber element and is bonded to the element. In turn, the rubber element locates onto horizontal pins attached to the coupling back plate, equally disposed on a PCD. The cap screws in the rear of the central hub, incorporated in a taper locking sleeve, are torque tightened to the values shown in the table in Section 1.4.2 below.

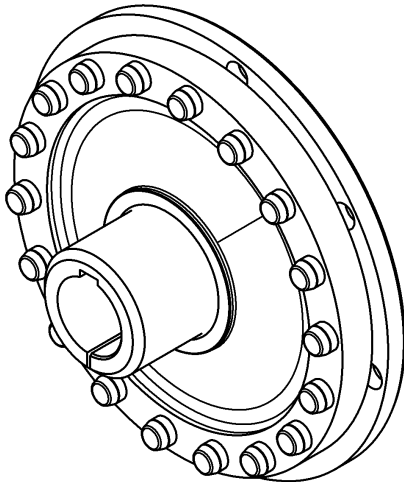

1.5.1 Preparation of the Centaflex Coupling for Pump Removal.

1. No preparation is required. The rubber element and central hub are locked to the pump shaft, and will be removed with the pump to gain access to the hub taper locking cap screws.

1.5.2 Centaflex Coupling Assembly Sequence

1. The capscrews connecting the back plate to the flywheel, and the capscrews in the taper locking for the rubber element hub, must all be tightened to the torque given in the table below, using a torque wrench.

Centaflex Size	Screw Size	Tightening Torque	
		Nm	mKp
CM-0120			
FLYWHEEL	M8	23	2.3
TAPER LOCKING	M6	9.5	0.95

2. Tightening with a torque wrench is particularly important. Tightening by feel will not do as experience has proved the tightening torques in such cases are far too low. Tightening torques which are too low will inevitably lead to slackening of the screws in service and consequently to the destruction of the coupling.

1.5.3 Replacement of the Steel Hub and Rubber Element

1. If it becomes necessary to replace the rubber element and hub, the pump must be removed to gain access to the six radial cap screws taper locking the hub to the pump shaft. Mark the hub position on the pump shaft before removing.
2. If it becomes necessary to replace the steel back plate and pins, the pump must be removed to gain access to the six radial cap screws securing the backplate to the flywheel.

1.6 Selwood D150R CC Data

Capacity (max)	315M ³ /h 69,290 UK gal/h
Delivery Head (max)	27m 88.5ft
Impeller Dia	231mm
Self Priming Lift (max)	8.8m H ₂ O 29ft H ₂ O
Solids Size (max)	45mm 1.75in
Air Handling Capacity:	
Single	24l/s
Prime	50ft ³ /min
Pump Speed	1800rpm Max
Port Size BS.4504 Table 6	150mm 6in

2 ROUTINE MAINTENANCE

Lack of routine maintenance is the most frequent reason for the breakdown of pumps. We earnestly advise users to ensure that at least the following actions are taken.

- Check these three oil levels daily:
 - Engine oil.
 - Air pump bearing housing oil.
 - Flushing chamber oil.
- Always drain water from the pump in cold weather when it is not running. Drain:
 - Pump body.
 - Delivery valve chamber.
 - Both sides of air pump
- Do NOT run the pump if significant quantities of water escape through the exhaust valve of the air pump. This pump is designed to handle moisture-laden air, but not to pump a high percentage of water. Refer to servicing instructions for further advice.
- Do NOT run the pump if malfunction is suspected in any of its parts. In particular, it must immediately be serviced if the level of oil in the flushing chamber varies daily, or if the oil becomes contaminated with the pumped fluid.
- A hose strainer should always be fitted to the free end of the suction line if there is a possibility of oversized solids entering the pump. The dimensions of rocks, pebbles, etc. must not exceed 45mm. Larger soft solids, however, of the type found in abattoir duties, for example, will pass freely through the pump. Refer to Selwood Ltd if in need of advice in this connection.
- As loss of prime and indeed loss of on-stream performance can easily arise as the result of leaking pipe work joints, we recommend that all line fittings associated with the pump should be checked periodically for air-tightness.
- It is most important to use the correct fuel oil in the engine. Make sure that it is appropriate for the weather conditions (summer or winter) and that it is clean and free from water and foreign matter. Unsatisfactory running performance, excessive wear and damage can all result from the use of an incorrect or contaminated fuel.
- Periodically check the tension of all nuts and bolts, especially those securing the engine and pump to the chassis.
- Pump servicing must always be carried out in accordance with the instructions given in this manual. Only components supplied and approved by Selwood Ltd should be used. It is advisable to hold a small stock of spare parts to cover breakdown circumstances. The Company will be pleased to give advice in this connection.
- Engine servicing must always be carried out in accordance with the instructions given in the manufacturer's manual. Do not hesitate to contact Selwood Ltd if the need for further advice arises.
- Please contact Selwood Ltd in the event of experiencing difficulty when servicing. The company will also be very pleased to give advice in connection with the machine's installation, operation and maintenance.
- All practical work must be carried out in compliance with the Health and Safety at Work Act, 1975. Always start the engine in accordance with the manufacturer's instructions.

NOTE: If the above advice is followed, the likelihood of an expensive break down will be greatly diminished. The pump should give a long and trouble free life if these measures are put into effect.

3 LUBRICATION AND FASTENING TORQUES

3.1 Pump Lubrication

It is most important to maintain the correct levels of oil in the flushing chamber and bearing housing, and to ensure that the oil is of the recommended quality and is free from contamination. Selwood recommend the use of the following BP/Castrol or Shell products, which should be applied as per the following table. In some territories, the following grades may be known under differing trade names, please contact Selwood if problems occur in identifying the correct product.

COMPONENT		BP GRADE
ENGINES		Vanellus C5 Global
Bearing Housing		BP Energrease LS-EP2
Flushing Chamber		C5 Global
Actuator Bore		Castrol Rustilo 431
Air Pump Bearing Hsg		C5 Global
Paper Gaskets		BP Energrease LS-EP2
Axle Shafts		BP Energrease LS-EP2
M10 Screws - Port Plate to Diffuser		Castrol Optimoly Paste HT
COMPONENT		SHELL GRADE
ENGINES		Rimula X 15w -40
Bearing Housing		Alvania EP LF 2
Flushing Chamber		Rimula X 15w -40
Actuator Bore		Shell Ensis SDB
Air Pump Bearing Hsg		Rimula X 15w -40
Paper Gaskets		Alvania EP LF 2
Axle Shafts		Alvania EP LF 2
M10 Screws - Port Plate to Diffuser		No Shell equivalent
COMPARTMENT	DRAIN INTERVAL	
	CHANGE OIL & FILTERS	CHECK & TOP UP
Engine Sump Isuzu	250 Hours	Daily
Air Pump Bearing Housing	750 Hours	Daily
Flushing Chamber	750 Hours	
Actuator Bore Impeller Bore Shaft Sleeve Bore	ON ASSEMBLY	
Paper Gaskets Axle Shafts Axle Pivot Assembly	ON ASSEMBLY	6 - 12
M10 Screws - Port Plate to Diffuser	ON ASSEMBLY	

3.1.1 Commissioning Period

Drain both pump chambers and engine within 100 running hours of commissioning either a new, or rebuilt pump, and refill with new oil to dipsticks level mark.

Air Pump bearing housing 1.2litres

Mechanical seal chamber and Oil Reservoir 1.8litres

Engine sump – Refer to Engine Instruction Book.

3.1.2 After Commissioning Period

If the pump is driven by a diesel engine, the oil in both pump chambers should be drained and renewed simultaneously with the time schedule laid down by the engine manufacturer. Under no circumstances should the period for the pump exceed 750 running hours.

3.1.3 Main Pump Bearings

1. Run pump to warm up bearings and keep running.
2. Remove 1/8" BSP vent plugs from bearing housing.
3. Charge each grease point with 20 grams of BP Energrease LS-EP2.
4. Leave pump running for about 30 minutes to allow any excess grease to escape through vents.
5. Replace 1/8" BSP plugs.

NOTE: Do not exceed recommended quantities of grease, as overheating will occur leading to premature bearing failure.

If excess grease should cause overheating it will be necessary to remove the excess by first removing the bearing covers, see General Maintenance.

Under normal conditions the bearing housing temperature should be sufficient to maintain hand contact.

3.2 Fastening Torques

Failure to tighten threaded fasteners correctly can easily lead to assembly breakdown. It is very important, therefore, when carrying out the instructions in this manual, to achieve the appropriate tensioning torques. In some cases, specific requirements are described in the instructions, which must always be implemented. The following torques, in particular, must be applied.

Item	Torque Nm	lbf-ft
M12 Actuator capscrew	81.3	60
M12 Air pump inner body to pedestal capscrew	95.0	70
M16 Impeller to shaft capscrew	122.0	90

3. Torque all fasteners as follows unless otherwise stated.

Diameter	Torque Nm	lbf-ft
M6	11.7	8.6
M8	28	20.7
M10	56	41.3
M12	98	72.3
M16	244	180

4 CONDITIONS OF WARRANTY

For a period of twelve months from delivery of any Selwood pump to the first user thereof, or eighteen months from the despatch of any such pump by Selwood, whichever period is the shorter, Selwood will repair or, at its option, replace any component, which in the opinion of Selwood has failed due to defective workmanship or materials.

For full terms and conditions please contact Selwood Ltd.

5 MAJOR SERVICING

5.1 Air Pump Maintenance

5.1.1 Delivery and Suction Valves

Failure of the pump set to prime quickly or to discharge the expected volume of air, may simply be due to faulty valve operation.

To inspect and service, proceed as follows:

1. Remove air hose (single prime item from suction valve box), after loosening relevant hose clips.
2. Note the orientation of the suction valve box and exhaust cover before commencing. Remove exhaust cover and suction valve box by releasing nuts and spring washers.

NOTE: The above actions allow the condition of the two valve rubbers to be checked. Do NOT attempt to remove valve studs. If valve rubbers are damaged, replace with new components. Pull old valves off stud heads, and discard.

3. Check and, if necessary, clean valve seats in outer pump body and valve box. Smear heads and grooves of studs with soft soap and push on new valves ensuring that they seat correctly.
4. The valve assemblies can now be replaced by reversing Instructions 1 and 2 of this procedure. It is advisable to fit new gaskets.

5.1.2 Actuator Valve

Another reason for the pump set failing to prime efficiently or to handle the expected volume of air, could be malfunction of the actuator valve.

To inspect and service, proceed as follows:

1. Remove nuts, spring washers, washers and screws, allowing outer pump body to be removed complete with attached delivery valve assembly. The actuator valve may now be examined. If it fails to seat efficiently on actuator or is in any way damaged, it should be pulled off the actuator nut and discarded.
2. Whilst the actuator valve is removed, it is advisable to examine the condition of the valve seat in the actuator, and also to check the security of the actuator screw. This should be checked and tightened to 60lbf ft (8.3kgf m) torque.
3. To replace actuator valve :
 - a) Smear soft soap on the conical end and groove of actuator screw.
 - b) Ease new valve rubber into position ensuring that it seats correctly.

NOTE: It is advisable to examine the condition of actuator seal whilst it is exposed. Refer to Section 5.1.3 Actuator Seal for servicing instructions.

4. To replace outer pump body assembly, fit and evenly tighten screws, washers, spring washers

and nuts, by sequentially turning each screw a small amount until they are all fully tensioned.

NOTE: It is important that the outer diameter of the actuator seal should be evenly clamped.

5.1.3 Actuator Seal

A further reason for the pump set failing to prime efficiently or to handle the expected volume of air could be a faulty actuator seal.

To inspect and service, proceed as follows:

1. Remove outer pump body complete with delivery valve assembly. Remove actuator screw.
2. Set actuator to top dead centre (maximum distance from inner pump body), by rotating engine shaft with starting handle. Using a tool that will not cut the rubber (such as a blunt screwdriver) and a lubricant (soap solution), remove actuator seal by prising it from the inner pump body.
3. Remove actuator complete with seal from drive rod.
4. To renew actuator seal :
 - a) Remove the failed component from the actuator.
 - b) Insert firstly one side and then the other into the actuator groove, using a blunt tool that will not cut the rubber.

NOTES: The seal is handed and will not enter the inner pump body if fitted the wrong way round. The correct assembly position for actuator seal is with the smaller diameter of its conical outer surface towards the inner pump body. It will be seen that the housing in the body is tapered in the same direction as the external surface of the seal.

5. At this stage it is advisable to examine the condition of actuator neck seal . This component should be replaced if any splits are evident on its visible surface. Refer to Section 5.1.4. Actuator Neck Seal.
6. Smear soft soap on the outside section of new actuator seal. Lightly grease actuator bore. Position actuator/seal assembly on drive rod, locate actuator screw and tighten to 60lbf ft (8.3kgf m) torque.
7. Replace actuator valve if removed, first smearing soft soap on the conical end and groove of actuator screw. The new valve should be eased into position by hand.
8. Before fitting outer pump body, reciprocate the actuator by fitting and rotating the engine's starting handle about ten times to encourage centralisation of the connecting rod bearings. During this procedure, the actuator seal is likely to rotate slightly in the inner pump body. Stop shaft rotation when actuator is at bottom dead centre (minimum distance from inner pump body).
9. Seat outside section of actuator seal in inner pump body recess by gently tapping with a non-metallic mallet.

10. Replace outer pump body assembly, and fit and evenly tighten screws, washers, spring washers and nuts, by sequentially turning each screw a small amount until they are all fully tightened. It is important that the outside diameter of the actuator seal should be clamped evenly.

5.1.4 Actuator Neck Seal

Another reason for the pump set failing to prime efficiently or to handle the expected volume of air could be failure of the actuator neck seal.

To investigate and service, proceed as follows:

1. Remove outer pump body complete with delivery valve assembly, and actuator with actuator seal as directed in Section 5.1.3 Actuator Seal Instructions 1 and 2.
2. Release hose clip allowing air hose to be disconnected from suction valve box. Screws should then be removed, leaving washers in the inner pump body.
3. The inner pump body can now be pulled by hand from the air pump bearing housing, if necessary twisting to overcome any tendency of the seal to stick to the drive rod. Remove and discard failed seal.
4. Smear new actuator neck seal with soft soap to assist fitting, position in inner pump body and push both components over drive rod using assembly tool (Part No. 0015102000) smeared with soft soap. Check that washers are in place, and fit and fully tighten screws. The heads of these screws should be fully contained within the recesses in the inner pump body.
5. Reassemble remaining components in accordance with Actuator Seal 5.1.3 Instructions 6 to 10, inclusively.

5.1.5 Pedestal bush and Seals

If oil leaks from ports in air pump pedestal it is probable that seals are excessively worn. Such a condition may also indicate that pedestal bush should be replaced.

To inspect and service, proceed as follows:

1. Drain oil from air pump bearing housing by removing drain plug and sealing washer.
2. Remove air pump components in accordance with Section 5.1.3 Actuator Seal Instructions 1 and 2, and to Section 5.1.4 Actuator Neck Seal Instructions 2 and 3.
3. Being careful not to damage the flat sealing faces of air pump pedestal, carefully withdraw pedestal complete with its bearing and sealing components from the air pump bearing housing and drive rod.
4. Carefully remove circlip and withdraw seal carrier complete with seal. Remove seal from housing. Use bearing drift, Service Tool 0015168000 to push out Pedestal bush (linear bearing). Examine condition of wiper and distributor seals together with bearing. If either are worn or damaged, we recommend that new seals and bearing should be

ordered and fitted in accordance with the following instructions.

5. To replace Pedestal bush carefully remove circlip allowing seal components to be pushed from pedestal with blunt punch or drift from bearing end. The drive rod bearing can now be removed using bearing drift (Part No. 0015168000) and the new component pressed into position so that one face is flush with base of bearing location within the pedestal.
6. Ensure that seal components are assembled in accordance with the following instructions.
 - a) The wiper seal is first assembled to the seal carrier using wiper seal insertion tool (Part No. 0010103000) with wiper lip uppermost.
 - b) Then lubricate seal housing and press in internal distributor seal with lip nearest bearing. Push into place with seal carrier together with wiper seal and the whole pressed into place with the wiper seal insertion tool (Part No. 0010103000). Care must be exercised when replacing circlip to ensure that the lip of the wiper seal is not damaged by the hand tools used. Refer to Section 5
7. Before replacing air pump pedestal assembly, check condition of drive rod, particularly if new bush has been fitted. If surface is significantly worn, the drive rod should be replaced in accordance with instructions given in Section 5.1.10.
8. Assembly tool (Part No. 0015101000) must be used when replacing bearing/seal housing assembly to ensure that the wiping edges of the seals are not damaged. The drive rod must be smeared with clean oil to assist this procedure. See Section 6.5. Gasket must be renewed. Always use a component supplied by Selwood Ltd. Ensure that ports in the air pump pedestal are in the 3 and 9 o'clock positions.
9. Reassemble remaining pump components in accordance with Section 5.1.4 Actuator Neck Seal Instruction 4 and 5.1.3 Actuator Seal Instructions 6 to 10, inclusively.
10. Replace drain plug together with sealing washer and refill bearing housing with clean oil to max. level on dipstick plug. Refer to Section 3.1 Pump Lubrication for details of the oil required for the air pump bearing housing.

5.1.6 Air Pump Mechanism

Should actuator fail to reciprocate when the pump is running, or if other abnormal conditions are suspected, the air pump mechanism should be immediately inspected to minimise the risk of consequential damage.

Proceed as follows:

1. Drain oil from air pump bearing housing and flushing chamber by removing drain plug and sealing washer.
2. Remove air pump components in accordance with Section 5.1.3 Actuator Seal and Section 5.1.4 Actuator Neck Seal Instructions 2 and 3 (discard actuator neck seal if it has failed).
3. Being careful not to damage the flat sealing faces of pedestal carefully withdraw pedestal complete with bearing and sealing components from air pump bearing housing and drive rod .
4. Carry out Section 5.1.7 Eccentric Shaft removal Instructions 8 to 18, inclusively.
5. Carefully remove drive rod and connecting rod . If second priming pump is fitted, repeat these operations, ensuring that the connecting rod, fulcrum pin and drive rod components are kept as sets, and can later be reassembled in their original positions.
6. Examine condition of all components and renew failed or significantly worn items. A replacement connecting rod, complete with bushes, should be ordered against sub-assembly (Part No. 1589102000).
7. To rebuild mechanism carry out Section 5.1.7 Eccentric Shaft fitting Instructions 1 to 16, inclusively.

5.1.7 Eccentric Shaft

Removal

1. Remove air pump components in accordance with Section 5.1.3 Actuator Seal instructions 1 and 2 and to Section 5.1.4 Actuator Neck Seal instructions 2 and 3.
2. Remove belt guard and pulley by releasing taper lock.
3. Remove key.
4. Remove 3/8" BSP drain plug and sealing washer ; drain and discard oil.
5. Remove four M8 hexagon socket head capscrews and spring washers.
6. Use two M8 tapped holes in air pump pedestal flange to jack off dowels.
7. Carefully remove the air pump pedestal complete with seals and linear bearing; remove and discard gasket. Take special care not to damage the drive rod surface.

8. Remove four M6 hexagon head screws and spring washers from bearing cover.
9. Remove bearing cover and gasket; discard gasket.
10. Bend back tabs on lock washer and remove bearing locknut; use 'C' spanner 1590180000.
11. Remove tab washer.
12. Remove four M6 hexagon head screws and spring washers from bearing cover.
13. Remove bearing cover complete with lip seal.
14. Remove gasket and discard.
15. Carefully pull shaft from housing complete with circlip, washer and inner race of bearing.
NOTE: It may assist dismantling if panel is removed. Take great care not to damage shaft, drive rod and bearings.
16. Remove con-rod/drive rod assembly and inspect bearing bushes.
17. Remove circlip and washer.
18. Use a bearing puller to remove inner race of bearing from shaft.

Fitting

1. Apply a few drops of Loctite 641 to the shaft and slide inner race of bearing onto its seat.
4. Fit washer and circlip.
5. Carefully slide shaft and bearing assembly into housing through the con-rod assembly and engage shaft end in bearing.
6. Fit tab washer engaging locating tab in shaft groove.
7. Fit bearing locknut and tighten with 'C' spanner; bend lock washer tab into groove.
8. Fit bearing cover with new gasket; secure with four M6 hexagon head screws and spring washers.
9. Fit bearing cover complete with lip seal and new gasket; secure with four M6 hexagon head screws and spring washers.
10. Fit new gasket.
11. Fit Service Tool 0015101000 to drive rod, and carefully lower the air pump pedestal, complete with seals and linear bearing, over. Locate pedestal flange over dowels and secure with four M8 hexagon socket head capscrews and spring washers.
12. Reassemble remaining air pump components in accordance with Section 5.1.4 Actuator Neck Seal instruction 4 and Section 5.1.3 Actuator Seal instructions 6 to 10 inclusively.
13. Refit key, pulley, taper lock bush and belt.
14. Align pulley with pulley on main shaft and tighten taper lock.
15. Refit belt guard.
16. Refill bearing housing with oil.

5.1.8 Lip Seal

Removal

1. Remove drain plug and sealing washer ; drain and discard oil.
2. Remove belt guard.
3. Release taper lock bush and remove with pulley; remove key.
4. Remove four M6 hexagon head screws and spring washers from bearing cover.
5. Remove bearing cover complete with lip seal.
6. Remove and discard gasket.
7. Pull lip seal from housing and discard.

Fitting

1. Clean and lubricate seal housing. Press in lip seal fully against abutment; lip nearest the bearing.
2. Lubricate shaft sealing surface.
3. Fit new gasket on bearing cover and slide assembly over shaft. Engage spigot and align screw holes.
4. Secure to bearing housing with four M6 hexagon head screws and spring washers.
5. Refit key, taper lock bush, pulley and belt.
6. Align pulley with main shaft pulley and tighten taper lock bush.
7. Replace belt guard.
8. Fill bearing housing with oil.

5.1.9 Roller Bearings

To investigate and service, proceed as follows:

1. Remove air pump components in accordance with Section 5.1.3 Actuator Seal instructions 1 and 2, and Section 5.1.4 Actuator Neck Seal instructions 2 and 3.
17. Remove air pump drive components in accordance with Section 5.1.7 Eccentric Shaft removal instructions 1 to 18 inclusively.
18. Examine bearings for excessive wear and replace both if either or both are worn.
19. Fit new bearings to drive shaft and refit into bearing housing in accordance with Section 5.1.7 Eccentric Shaft fitting instructions 1 to 16 inclusively.
20. Reassemble remaining air pump components in accordance with Section 5.1.4 Actuator Neck Seal instruction 4 and Section 5.1.3 Actuator Seal instructions 6 to 10 inclusively.

5.1.10 Con Rod and Drive Rod

These items can only be purchased with the bearings finish machined and reamed:

To investigate and service use fitting and removal procedures, Section 5.1.9.

5.1.11 Drive Belt

Another reason for the pump set failing to prime efficiently, or handle the expected volume of air could be the poor condition of the air pump drive belt or pulleys.

To investigate and service, proceed as follows:

1. Remove air pump pulley guard.
2. Remove one half of coupling guard.
3. Remove rubber coupling element.
4. Release taper lock bush on the air pump shaft.
5. Carefully remove belt and examine for tooth damage and cracking. If faulty replace with new belt.
6. Check pulleys for damage. Change if required in accordance with pulley manufacturers instructions.
7. Thread the toothed belt between the flywheel plate and pump shaft end and over the pulleys.
8. Line up air pump pulley with main shaft pulley and tighten the taper lock bush .
9. Check belt tension and adjust if necessary. See Section 5.1.12.
10. Reassemble coupling and guards.

5.1.12 Drive Belt Tension

Required Tension

A load of 7 - 14N (3.0lbf) applied across the belt at mid span should give a deflection at that point of 3.5mm (0.12ins). This may be measured using a spring balance, bar, and dial indicator.

Adjustment

The belt tension is set by varying the distance between pump and air-pump shaft centres using shims. Jacking screw holes are provided in the pump bearing housing flanges to raise and lower the air pump during adjustment.

5.1.13 Air Pump Assembly

Sometimes it is more practical to service the air pump away from the main pump assembly.

To allow remote service proceed as follows:

1. Remove drive belt as directed in Section 5.1.11 Drive Belt, instructions 1 to 5.
2. Disconnect separator hose and silencer hose.
3. Remove four M12 hexagon socket capscrews and spring washers.
4. Insert two screws in the tapped holes midway along the pump bearing housing flanges and jack the air pump assembly off the dowels.
5. Retain shims and note positions.
6. Carryout the relevant servicing required.
7. Replace shims or reselect new shims by following the adjustment procedure Section 5.1.12 Drive Belt Tension.

8. Fit air pump bearing housing flange over dowels, fit four spring washers and four M12 hexagon socket capscrews. Pull the air pump down evenly.
9. Reassemble belt as Section 5.1.11.
10. Check belt tension as Section 5.1.12.
11. Refit guards and air pump hoses.

5.2 Separator Maintenance

5.2.1 Float

If water in significant quantities continuously passes through the exhaust valve of the air pump, it is probable that the float is in need of replacement.

To inspect and service, proceed as follows:

1. Disconnect air hose by loosening hose clip.
2. Remove nuts and washers and lift off separator cap complete with peel valve/upper diffuser assembly.
3. Examine condition of float and replace with new component if punctured or significantly worn.
4. Check condition of peel valve rubber and bush replacing them, if necessary, in accordance with Section 5.2.2 Peel Valve. Also check for deposits of solids likely to interfere with the smooth working of the float system.
5. When fitting a new float, ensure that it is securely tightened against nut. During this procedure the float should be positioned on the rod so that the operating plate with its associated peel valve fasteners is just clear of the central clamp bar screws, when the float is located in the upper diffuser cone.
6. If all components are seen to be in satisfactory condition, replace separator cap assembly, washers and nuts. Alternately tighten each nut a small amount to ensure that the cap is pulled down evenly. Do not over tighten. Replace air hose and re-tension hose clip.

5.2.2 Peel Valve

If significant quantities of water are discharged from the exhaust valve of the air pump, and the float is in satisfactory condition, it is probable that a fault exists in the peel valve assembly.

To inspect and service, proceed as follows:

1. Remove separator cap sub-assembly to and unscrew float and nut.
2. Release screws and spring washers to allow upper diffuser/valve assembly to be withdrawn.
3. Remove screws and sealing washers to allow upper diffuser to be removed from the port plate sub-assembly.
4. Examine condition of peel valve rubber and air ports in plate which it should completely cover when the float is fully raised. If the rubber does not seat correctly, is distorted, or in any way damaged, it must be removed and discarded by releasing screws.

5. To fit new peel valve rubber :
 - a) Carefully clean existing parts thoroughly, especially surfaces of port plate, and clamp bars and position new rubber on plate.
 - b) Assemble screws, clamp bar, clamp bar seal , washer and nuts in sequence shown on drawing. Alternately tighten each nut a small amount to ensure that even clamping pressure is produced. Correctly tightened nuts will not cause the clamp bar to distort the rubber.
6. Carefully attach the ends of the valve rubber to the operating plate, noting that the components and method of assembly are identical to those described in Instruction 5 of this Section except that clamp bar seal is omitted. Again, ensure that the nuts are not over tightened.
7. After completing Instructions 5 and 6 of this Section, check that the peel valve rubber is capable of closing all of the air holes in port plate when operating rod is square to the plate and fully lifted.
8. Check condition of bush in upper diffuser and replace, together with clip and nitrile washer, if significantly worn.

NOTE: The operating rod is normally a slack fit in the bush.

9. Position port plate sub-assembly on upper diffuser, fit washers after checking that they will seal efficiently and fully tighten screws. Reassemble nut and screw float on to operating rod and tighten securely in accordance with Section 5.2.1 Float Instruction 5.
10. Recheck operation of peel valve rubber to ensure that it fully covers air ports in plate when the float is located in the upper diffuser cone. In this position there should be a gap of 3.5 mm between the heads of the centre clamp bar screws and the operating plate. If the dimension is incorrect, adjust position of float on operating rod.
11. Examine condition of gasket and renew, if necessary, before installing between port plate and separator cap . Fit spring washers and screws each of which should be sequentially turned a small amount until fully tightened. Gasket must be evenly compressed.
12. Replace separator cap sub-assembly in accordance with Section 5.2.1 Float Instruction 6.

5.2.3 Deposits of Solids^{†‡}

When handling liquids containing solids capable of adhering to product wetted surfaces, it is advisable periodically to check the valve system in the separator.

To inspect and service, proceed as follows:

1. Remove separator cap sub-assembly in accordance with Section 5.2.1 Float Instructions 1 and 2, allowing separator body together with lower diffuser, to be lifted off the suction tube .
2. Remove any deposits of scale from lower diffuser and check condition of welds securing its circular bottom to the perforated cylinder. Remove any solids that may have accumulated in the suction tube, renew gasket and reposition separator body/lower diffuser assembly on suction tube.
3. Remove deposited materials from surfaces of upper diffuser (and note, in particular, condition of welds securing cone and disc to perforated diffuser body. Also examine diffuser bush and operating rod, and replace if significantly worn in accordance with Section 5.2.2 Peel Valve Instructions 3 to 11. Remove all deposited solids that would interfere with the free movement of the mechanism, obstruct the passage of air across the port plate holes, or inhibit the flow of water (through the holes in the upper diffuser, for example).
4. Once it is established that all components are in a satisfactory condition and are free from scale, replace separator cap sub-assembly in accordance with Section 5.2.1 Float Instruction 6. Any re-assembly work carried out on the peel valve assembly should be in accordance with Section 5.2.2 Peel Valve commencing Instruction 1.

5.3 Impeller, Mechanical Seal, Wear Plate and Delivery Valve Maintenance

5.3.1 Impeller

Generally speaking, it is only necessary to remove the impeller if the existing component has become severely abraded, or if access to other rotating parts is required.

To remove and replace, proceed as follows:

1. Drain oil from the mechanical seal chamber and reservoir by removing the 3/8" BSP plug. The condition of the oil will indicate whether or not the mechanical seal has been functioning correctly. If contamination is evident, the mechanical seal

must be replaced in accordance with Section 5.3.3 Mechanical Seal.

2. Remove air hose item from separator cap , after loosening relevant hose clip.
3. Remove nuts and washers, and lift off separator cap complete with peel valve/upper diffuser assembly.
4. Lift separator body complete with lower diffuser off suction tube.
5. Remove the twelve M12 nuts and spring washers joining the suction tube and volute.
6. Jack the suction tube away from the volute using two M12 bolts in the two tapped holes in the suction tube flange.

NOTE: The suction tube and separator may be removed as an assembly with suitable lifting gear (weight = 84kg).
7. Take care not to damage the shims, 'O' ring or wear plate.
8. Release the M16 capscrew, R.H. thread. The impeller may be held stationary by placing a piece of wood between an impeller blade and the cutwater.

NOTE: Take care when disengaging the impeller capscrew as the compressed mechanical seal spring will push the impeller off the shaft.
9. Remove the impeller complete with M16 capscrew, impeller collar, Dowty seal, 'O' ring and the mechanical seal spring. The impeller spacer 'O' ring may also come away with the impeller.
10. Grease and fit a new spacer 'O' ring.
11. Engage mechanical seal spring on the rotating face carrier.
12. Oil impeller bore.
13. Slide impeller onto shaft ensuring that the hub passes inside the spring.
14. Fit impeller collar with new 'O' ring.
15. Fit impeller.
16. Fit M16 capscrew with a new greased Dowty washer. Apply Loctite Nutlock 242 to the thread.
17. Compress mechanical seal spring and tighten M16 capscrew to 90 lbf-ft (122 Nm) torque. It is essential that this screw is correctly tensioned. During this operation, it will be necessary to lock the impeller by means of a wooden block wedged between the impeller blades and volute casing. Remove block after use.
18. Check the impeller back clearance is 0.5mm. For adjustment see Section 5.3.2 Setting Impeller Clearances instructions 1 to 4 inclusively.
19. Inspect suction tube 'O' ring and replace if necessary.
20. Remove jacking screws from suction tube flange.
21. Check the impeller front clearance is 0.5mm. For adjustment see Section 5.3.2 Setting Impeller Clearances instructions 5 to 12 inclusively.

[†] Use lower Diffuser (Part No. 1594161000) for sludge handling duties. This is recognised by holes in the base as well as around the side.

[‡] Use lower Diffuser (Part No. 00-15-038000) for other applications where no solids are present which can adhere to the internal surfaces.

22. Fit suction tube to volute with the necessary shims, and secure with twelve M12 nuts and spring washers.
23. Reposition separator body sub-assembly on suction tube, and fit separator cap assembly. Assemble washers and nuts and alternatively tighten each nut a small amount to ensure that the cap is pulled down evenly. Do NOT over-tighten.
24. Reposition air hose on spigot of separator cap and tighten hose clip.
25. Refill oil reservoir with 10W30 oil to dipstick level .

5.3.2 Setting Impeller Clearances

General

Clearances at the front and back of the impeller must be maintained at 0.5mm maximum. Increasing the clearance will result in loss of hydraulic efficiency and reduced bearing life. Both front and back clearances are established by shims.

Back Clearance

This should be checked using feeler gauges with access through volute discharge. If adjustment is required:

1. Remove impeller in accordance with Section 5.3.1 Impellor instructions 1 to 9 inclusively.
2. Remove spacer with the mechanical seal rotating face attached using Service Tool 1590170000 engaged in the spacer slots.
3. Add or remove shims, 0.25mm and 0.1mm, to give the required clearance. Ensure that the shims are correctly seated on the shaft shoulder.
4. Refit impeller in accordance with Section 5.3.1 Impellor instructions 10 to 25 inclusively and recheck clearance.

Front Clearance

5. Remove the suction tube from the volute casing in accordance with Section 5.3.1 Impellor, instructions 1 to 6 inclusively.
6. Remove shims.
7. Refit suction tube and front wear plate assembly.
8. Lightly tighten four equi-spaced M12 nuts on volute studs sufficiently to just nip the impeller.
9. Use feelers to measure the clearance between the suction tube flange and the volute.
10. Calculate the shims required to give a maximum clearance of 0.5mm.
11. Fit shims, 0.25mm or 0.15mm, taking care not to damage the 'O' ring.
12. Refit suction tube in accordance with Section 5.3.1 Impellor, instructions 22 to 25 inclusively.

5.3.3 Mechanical Seal

The mechanical seal should be replaced if the flushing chamber oil continuously leaks into the pumped fluid, or if the oil becomes contaminated with the product. This latter condition is sometimes indicated by leakage

of fluid out of the breather cap. Under extreme conditions, pumped fluid may be seen escaping out of the vent at the bottom of flushing chamber.

In the event of abrasive materials being detected in the oil, it is likely that lip seal will have become worn and necessitate replacement in accordance with Section 5.4.1. Lip Seals.

Daily checks on oil condition should ensure that seal failure is detected before damage occurs to related components. If the mechanical seal leaks, proceed as follows:

1. Remove impeller in accordance with Section 5.3.1 Impellor Instructions 2 to 9 inclusively.
2. Remove spacer complete with mechanical seal rotating element using Service Tool 1590170000 engaged in the spacer slots.
3. Remove impeller spacer shims from the shaft.
4. Using seat removal tool (Part No. 0015166000), withdraw mechanical seal stationary seat and rubber ring from recess in mounting pedestal.
5. The rotating parts of mechanical seal should now be discarded.
6. Once removed, examine condition of spacer and replace with new component if unacceptably corroded or worn.

IMPORTANT ADVICE



New mechanical seal components must be handled with great care, in particular, the seal faces must not be touched by hand and must only come into contact with clean soft paper that is free from abrasive materials. Premature seal failure is likely to occur if this advice is not heeded.

7. To replace the mechanical seal repair ring fitted from pump serial number 150SA 377 proceed as follows.
8. To gain access to the seat, remove lip seal components in accordance with Section 5.4.1 Lip Seals instructions 1 to 11 inclusively.
9. Remove the four screws that secure the repair ring to the pedestal. Apply heat to the old repair ring to break down the Loctite retainer bond. Using a suitable drift, or block of wood, tap out the old repair ring.
10. Clean up the housing with Scotchbrite or similar and apply Loctite retainer 638 to the new repair ring.
11. Insert the repair ring into the pedestal ensuring that the screw holes are correctly aligned. Apply Loctite screwlock 222 to the four screws and tighten evenly. Leave for 15-30 minutes for the bond to begin curing and to reach handling strength.

12. If replacing the lip seals proceed in accordance with Section 5.4.1 Lip Seals instructions 12 to 23 inclusively. If not, replace the bearing housing assembly, taking care not to damage the shaft on the mechanical seal housing.

Important Pre-Installation Checks

- a) Condition of main lip seals and shaft surfaces must be good. See 5.4.1.
 - b) Seal flushing chamber must be clean, free from grit and silt deposits, otherwise oil properties will be impaired.
 - c) Shaft bearings must be in good condition and have no more than 0.006" axial movement. Check with dial indicator. If excessive, reset or replace bearings. See Section 5.4.3 for resetting procedure. Clearance new is 0.002" to 0.003".
 - d) Size and condition of stationary seal recess in pedestal must be checked. Maximum permissible diameter is 3.625". If oversize a new pedestal or new wear repair ring must be fitted See above.
 - e) Wear plates, if excessively worn, should be replaced to regain a running clearance of 0.020" \pm 0.004". See Section 5.3.4 and 5.3.5. For resetting See Section 5.3.2
 - f) An old corroded impeller cannot be used unless the size and surface finish of the rear drive boss is as new. Size 2.753" to 2.758" clean unpitted surface with a generous chamfer at the spacer end.
13. Ensure all pre-installation checks have been made. Inspect the lead in chamfer on the pedestal stationary face recess, this should be smooth, clean and corrosion free.
 14. Check the new or cleaned up impeller for a tight but sliding fit on the shaft and key.
 15. Check the impeller back clearance and adjust if necessary. See Section 5.3.2. A clearance of 0.020" \pm 0.004" should be achieved.
 16. Lubricate the stationary seal recess and lead with a very diluted solution of soft soap. Lubricate the outside face assembly with clean water only and using tool 1596131000 push the seal face firmly to the base of the recess. The use of the tool will ensure that the face is fitted square to the shaft axis. Check face is clean when tool is removed.
 17. Lubricate impeller key with oil and fit to shaft.
 18. The shaft spacer should be lubricate inside and slid into its final position on the shaft against the shims on the shaft shoulder.
Note: No 'O' ring is required in the spacer recess.
 19. Lay the impeller blade side down on a firm surface. Lightly oil the bore and keyway.
 20. With clean hands, apply soap to the outside of the impeller boss and lead. Lightly soap inside the back of the rubber bellows. Then with a twisting action applied to the rear of the spring and carrier ring, screw the bellows onto the impeller boss. Ensure the bellows is fully located against the back of the impeller

21. Check that no dirt or contamination has got onto the seal surface. Apply a couple of drops of clean oil to the face and spread to a thin film with a clean finger.
22. The impeller/seal assembly can now be mounted on the shaft taking great care not to contact the seal face on the shaft or key whilst locating the shaft in the bore. Keep pushing the impeller until the seal faces contact. Refit impeller retaining screw and reassemble pump in accordance with Section 5.3.1 Impellor, instructions 10 to 25 inclusively.

5.3.4 Front Wear Plate

Failure of the pump set to pump under suction could be due to a worn wear plate or incorrect clearance between impeller and front wear plate.

1. Remove suction tube and separator assembly in accordance with Section 5.3.1 Impellor instructions 1 to 6 inclusively.
2. Remove eight M6 slotted cheese head screws and washers securing front wear plate complete with 'O' rings to Suction tube.
3. Use circumferential groove to lever front wear plate away from suction tube and spigot. Discard 'O' rings and clean suction tube and wear plate interface.
4. Check condition of front wear plate for excessive wear or damage and replace if necessary.
5. Lightly grease suction tube and front wear plate interface and fit new 'O' rings in to corresponding grooves on Suction tube.
6. Examine M6 slotted cheese head screws and replace if damaged.
7. Offer front wear plate to suction tube and carefully align screw holes without dislodging 'O' rings. Fit washers and M6 slotted cheese head screws with Loctite Nut lock 242 applied to threads.
8. Check impeller front clearance and adjust if necessary in accordance with Section 5.3.2 Setting Impeller Clearances instructions 7 to 8 inclusively.
9. Examine suction tube and volute 'O' ring and replace if necessary.
10. Refit suction tube and separator assembly in accordance with Section 5.3.1 Impellor instructions 22 to 25 inclusively.

5.3.5 Rear Wear Plate

Failure of the pump set to pump under suction could be due to a worn wear plate or incorrect clearance between impeller and rear wear plate.

1. Remove suction tube, separator assembly and impeller in accordance with Section 5.3.1 Impellor instructions 1 to 9 inclusively.
2. Remove eight M6 slotted cheese head screws and washers securing Rear wear plate complete with 'O' rings to support ring interface on mounting pedestal.

3. Carefully lever rear wear plate away from mounting pedestal and its spigot location. Discard 'O' rings and clean support ring and rear wear plate interface for excessive wear or damage and replace if necessary.
4. Lightly grease rear wear plate and support ring interface and fit new 'O' rings in to corresponding grooves on mounting pedestal.
5. Examine M6 slotted cheese head screws and replace if damaged.
6. Offer rear wear plate to mounting pedestal and carefully align screw holes without dislodging 'O' rings. Fit washers and M6 slotted cheese head screws with Loctite Nut lock 242 applied to threads.
7. Check impeller back clearance and adjust if necessary in accordance with Section 5.3.2 Setting Impeller Clearances instructions 2 to 3 inclusively.
8. Examine support ring and volute 'O' ring and replace if necessary.
9. Refit suction tube, separator assembly and impeller in accordance with Section 5.3.1 Impellor instructions 10 to 25 inclusively.

5.3.6 Delivery Valve

Failure of the pump set to pump under suction lift conditions could be due to a fault in the delivery valve assembly.

To inspect and service, proceed as follows:

1. Ensure that pump has been shut down and the delivery line has been drained.
2. Release four long nuts, rotate inspection cover anti-clockwise until free of studs and nuts and remove cover. It now becomes possible to lift valve flap rotating through opening by hand to expose valve seat so allowing foreign matter to be removed. Also undertake a preliminary check of the condition of the valve rubber.
3. If further disassembly of valve is required to replace valve seat, Valve rubber and Valve pivot pin and bushes, proceed with following instructions, If not refit cover.

Valve Rubber

Valve rubber may be damaged or worn preventing sealing with valve seat. Replacement instructions as follows:-

Holding flap valve assembly together.

1. Carefully remove retaining plate complete with bolt, sealing washer and star lock washer.
2. Lever valve rubber away from Valve hinge. Examine condition of Valve rubber, especially along hinge line and seating surface. Discard if damaged or mis-shaped.
3. Clean Valve hinge and retaining plate of loose debris and reassemble flap valve with new valve rubber, new M12 self locking nut and if required new sealing washer.

4. Check Valve is sealing fully and refit inspection cover

Valve Seat.

Valve seat may be damaged or worn preventing sealing with valve rubber. Replacement instructions as follows:

1. Remove eight M16 nuts and washers from studs securing valve to volute. Carefully lift Delivery valve body complete with flap valve parts off volute.
2. Remove protective plug on base flange of valve body and unscrew M8 socket setscrew holding valve seat (COG) in place.
3. Remove valve seat from valve body. Discard 'O' ring fitted to valve seat. Examine condition of valve seat for excessive wear or corrosion. Clean part and refit. Replace if necessary.
4. Before refitting valve seat, clean and grease 'O' ring groove and fit new 'O' ring.
5. Push valve seat into valve body until registered on abutment. Smear Loctite 242 on threads of M8 socket setscrew and insert into valve body to lock valve seat. Fit protective plug.
6. Before refitting valve onto volute check condition of gasket and replace if necessary. Position valve onto volute flange and fit M16 nuts and washers. Carefully tighten nuts in small increments to produce even clamping on gasket.
7. Check valve is sealing fully and refit inspection cover.

Valve Pivot Pin and Pivot Bushes

Valve pivot pin and bushes may be damaged or worn preventing valve rubber sealing with valve seat. Replacement instructions as follows:

1. Remove eight M16 nuts and washers from studs securing valve to volute. Carefully lift Delivery valve body complete with flap valve parts off volute.
2. To enable access to pivot pin remove the two circular pivot caps with gaskets situated each side of delivery valve held in by screws and washers. Discard pivot cap gaskets after removal.
3. Unscrew three socket setscrews locking the valve flap to pivot pin.
4. Push pivot pin completely out of valve body and remove. Push pivot pin bushes and spacers out of body.
5. Clean removed parts and check condition of pivot pin and pivot pin bushes and spacers for corrosion, damage or excessive wear and replace with new parts if necessary.
6. Clean the pivot bush housings in valve body and push in pivot bushes until registered on internal abutments.

7. Push clean pivot pin through fitted pivot bushes, spacers and valve flap. Centralise valve flap on to valve seat and centre pivot pin within valve flap. Smear M8 socket setscrews threads with Loctite 242 and Lock valve flap in place.
8. Renew pivot cap gaskets and replace pivot caps. Fit in place with screws and washers.
9. Before refitting valve onto volute check condition of gasket and replace if necessary. Position valve onto volute flange and fit M16 nuts and washers. Carefully tighten nuts in small increments to produce even clamping on gasket.
10. Check valve is sealing fully and refit inspection cover.

5.4 Maintenance of Lip seals, Headland V Seal, Bearings and Main shaft.

5.4.1 Lip Seals

For service and inspection proceed as follows:

1. Remove impeller and mechanical seal in accordance with Section 5.3.1 Impellor instructions 1 to 9 and Section 5.3.3 Mechanical Seal instructions 2 to 4 inclusively.
2. Remove coupling guards and flexible element from coupling.
3. Disconnect air pump exhaust hose from air pump. Make sure Oil Reservoir is fully drained then disconnect Oil Reservoir Hoses and Breather Hose from bearing housing. Remove three bolts that hold the pump to the chassis from mounting pedestal and loosen fourth on delivery side of pump.
Support bearing housing and air pump assemblies in a sling (assembly weight = 76kg).
5. Remove twelve M12 nuts and spring washers, from the studs securing the bearing housing flange to the mounting pedestal.
Carefully withdraw the bearing housing with the air pump attached.
NOTE: Move axially for at least 100mm for shaft to clear mechanical seal housing.
6. Stand assembly on a clean flat surface, with the shaft vertical, on the coupling flange with wooden packing under the air pump dish.
Remove six M6 hexagon head screws and spring washers from the bearing front cover.
7. Using the tapped holes in the bearing front end cover flange jack it away from the bearing housing.
8. Remove bearing front end cover complete with lip seals and remove jack screws.

9. Remove and discard gasket.
10. Inspect shaft sealing surface for damage. If necessary remove the shaft in accordance with Section 5.4.3 Bearings.
11. Remove lip seals and clean seal housings.
12. Oil new seals and push into housings, both seals must have lips facing towards the impeller.
13. Remove excess grease from in front of the bearing to just expose the rollers. This will avoid the likelihood of future over packing.
14. Ensure breather is clear.
15. Fit new gasket ensuring that the vent hole in the bottom of the seal oil chamber is not covered.
16. Grease shaft on the sealing surface and fit bearing front end cover complete with lip seals.

NOTE: The plug must go to the bottom of the chamber in the recess.

17. Fit six M6 screws and spring washers, and torque to 7 to 8 lbf-ft (9.5 to 10.8 Nm).
18. Fit new 'O' ring to bearing housing spigot and smear with grease or oil.

Replace bearing housing assembly taking care not to damage the shaft on the mechanical seal, housing.

19. Fit twelve M12 nuts and spring washers, and torque to 60 lbf-ft (81 Nm).
20. Swing the mounting pedestal and attached assembly back into position and insert chassis bolts, spring washers and nuts.
Torque chassis bolts to 150 lbf-ft (203 Nm).
21. Reinstall flexible element of drive coupling.
22. Refit coupling and belt guards. Reconnect air pump exhaust hose. Reconnect Oil Reservoir hoses and Breather hose to Bearing housing.
23. Refit impeller and mechanical seal in accordance with Section 5.3.1 Impellor instructions 10 to 25 inclusively.

NOTE: If lifting gear is not available the air pump may be separated from the bearing housing reducing the lifted weights to:

- a) Air Pump Assembly = 40Kg
- b) Bearing Housing Assembly = 38.5kg.

For air pump assembly removal and installation see Section 5.1.13.

5.4.2 Headland V Seal

For service and inspection proceed as follows:-

1. Remove coupling guards and flexible element from coupling.
2. Disconnect air pump exhaust hose from air pump. Remove three bolts hold pump to chassis from mounting pedestal and loosen fourth on delivery side of pump.

3. Swing mounting pedestal and attached assembly anti-clockwise (viewed from above) until both sides of coupling are clear of each other.
4. Remove pump end of drive coupling from pump shaft noting position of centre hub or taperlock in relation to drive shaft end or air pump drive pump pulley.
5. Remove air pump drive belt in accordance with Section 5.1.11 Drive Belt instructions 4 to 5 inclusively. Loosen screws in pump pulley taperlock and disengage pump pulley and taperlock followed by inertia disc /spacer from pump drive shaft.
6. Remove circlip from groove in drive shaft collar. Gently prise out Headland V Seal from recess in bearing drive end cover.
7. Examine seal for damage or excessive wear and discard if necessary
8. Clean and lightly grease sealing area recess in bearing drive end cover and outside diameter of drive shaft collar lightly grease.
9. Press in new Headland V Seal and replace circlip and spacer.
10. Refit taperlock and pump pulley ensuring that the taperlock is pushed up against spacer and tighten in place.
11. Refit air pump drive belt, pulley and taperlock in accordance with Section 5.1.11 Drive Belt instructions 6 to 9 inclusively.
12. Reassemble pump end of drive coupling and fit to drive shaft to previously noted original position.
13. Reinstall flexible element of drive coupling, reposition pump onto pump mounting holes and secure in place with bolts, washers and nuts.
14. Refit coupling and belt guards and reconnect air pump exhaust hose from air pump.

5.4.3 Bearings

For service and inspection proceed as follows:

1. Remove bearing front-end cover complete with Lip seals in accordance with Section 5.4.1 Lip Seal Instructions 1 to 11 inclusively.
 2. Remove headland V seal in accordance with Section 5.4.2 Headland V Seal instructions 1 to 6 and air pump assembly from pump pedestal in accordance with Section 5.1.13 Air Pump Assembly instructions 1 to 5 inclusively.
 3. To enable access to internal bearings remove bearing drive end cover by unscrewing six M6 screws and washers. Remove drive end cover and discard gasket.
 4. Remove drive shaft collar by unscrewing two setscrews completely from it. Using a 'C' type spanner remove drive shaft collar from drive shaft.
 5. Mount the assembly on a press with the shaft vertical and the impeller end downwards. A minimum of 30mm clearance beneath the shaft is required.
6. Remove plastic protection plug from shaft end.
 7. Protect shaft end and engage in the press to remove drive end and volute end bearings consisting of a bearing cone and cup.
 8. Press drive shaft through bearings, 26mm movement will clear bearing cones from their seats.
 9. Hold shaft steady and carefully lift off bearing housing complete with bearing cups.

NOTE: Take great care not to damage the shaft particularly on the sealing surface (largest diameter of drive shaft).
 10. Press the remaining bearing cone off its seat, over the next, and remove from shaft.
 11. Remove the bearing cups from the bearing housing using a two-claw puller engaging in the pockets cast into the housing behind the cups.
 12. Discard old bearing. Thoroughly clean all bearing housing surfaces. Inspect drive shaft for damage, replace if necessary and clean all drive shaft surfaces thoroughly, smear oil on bearing mounting diameters
 13. Press new bearing cups of bearings into bearing housing ensuring that they are right up against their abutments.
 14. Pack the impeller end bearing cover about 1/3rd full with BP Energrease LS-EP2.
 15. Press impeller end bearing cone onto the shaft using a suitable tube that contacts the inner race only. The taper roller bearings are mounted back to back. The bearing must first be pressed over the drive end bearing seat. Ensure that it is pressed right up against the shaft abutment.
 16. Pack the rollers full with BP Energrease LS-EP2.
 17. Hold the shaft vertical with the impeller end downwards and carefully lower the bearing housing over.
 18. Pack the drive end bearing rollers full with BP Energrease LS-EP2.
 19. Lower the drive end bearing cone over the shaft and press about 20mm onto its seat.
 20. Screw the shaft collar up to bearing.
 21. Fit half coupling to shaft.
 22. Fill hole in shaft end with SKF hydraulic oil ref. LHM3D1 and connect the hose from the oil injection pump SKF 729123.
 23. Clamp the bearing housing flange in a soft jaw vice with the shaft horizontal and the coupling nearest to you.
 24. Set up a dial type indicator on the shaft impeller end.
 25. Measure the axial clearance in the bearings by moving the shaft back and forth whilst turning to bed in rollers.

26. Pump up the hydraulic oil pressure until the bearing can be moved by tightening the shaft collar with a 'C' spanner (SKF HN11).

SET BEARING AXIAL CLEARANCE TO 0.0015 TO 0.0025 INCHES (0.0381-0.0635 mm) by repeating stages 25 and 26.

NOTES:

- a) One complete turn of the shaft collar gives 2mm axial movement.
 - b) Do not carry out the bearing adjustment procedure with lip seats fitted as they will impede shaft movement and may cause errors.
 - c) A special tool is available to facilitate bearing adjustment Ref. WRS 987.
 - d) The correct bearing clearance must be accurately set to ensure satisfactory operation. Failure to do this will result in overheating and consequently reduced bearing life.
 - e) Use BP Energrease LS-EP2 only.
 - f) Do not pack grease into outer covers, excess causes overheating and premature bearing failure.
27. Fit and tighten two setscrews to lock shaft collar to shaft.
28. Remove the dial indicator.
29. Disconnect the hydraulic pump and drain hydraulic oil from shaft. Discard oil and fit plastic plug in shaft end to protect the tapped hole.
30. Remove the half coupling.
31. Refit Lip seals, Mechanical Seal, Impeller and remaining pump end parts in accordance with Section 5.4.1 Lip Seals instructions 12 to 19 inclusively and Section 5.3.1 Impeller instructions 10 to 24 inclusively.
32. Refit Air pump assembly to pump pedestal in accordance with Section 5.1.13 Air Pump Assembly instructions 7 to 8 inclusively.
33. Refit Headland V Seal in accordance with Section 5.4.2 Headland V Seal instructions 8 to 14 inclusively.
34. Reconnect Oil Reservoir Hoses and Breather hose from Oil Reservoir to Bearing housing and Refill with reservoir with 10W30 oil to dipstick level.

5.4.4 Main Shaft

For service and inspection proceed as follows:

1. Remove main shaft in accordance with Section 5.4.3 Bearings instructions 1 to 12 inclusively.
2. Reuse existing bearings if condition is satisfactory.
3. Fit new main shaft. During reassembly check front and back impeller clearances in accordance with Section 5.3.2 Setting Impeller Clearances.
4. Reassemble pump in accordance with Section 5.4.3 Bearings instructions 13 to 34 inclusively.

5.5 Chassis Maintenance

It is possible to work on individual components of the chassis without removing either the engine or the pump unit. In all cases work should be undertaken on level ground and care should be exercised to ensure that the pump set is fully immobilised. If the chassis is to be completely dismantled, both the engine and pump unit should be removed in compliance with the requirements of Health and Safety at Work Act, 1975.

5.6 Canopy - Canopy Removal

To remove the canopy, proceed as follows:

1. Disconnect the battery positive and negative and remove the battery assembly.
2. Disconnect exhaust pipework within canopy having first removed insulation blanket.
3. Disconnect emergency stop wiring plugs from stop buttons from within canopy. Tie up onto engine to prevent damage to wiring.
4. Remove suction and discharge aperture cover plates. Remove foam plugs and rubber blanking gaskets.
5. Remove discharge fitting from discharge flange of pump.
6. Release the base fasteners which pass up through the upper flange of the skid base. Remove these in turn to release the canopy from the skid base.
7. With the canopy released undo the nuts from the centre-lifting eye. When these are released the canopy is ready to be lifted clear.
8. In order to prevent damage to the engine radiator and to ensure a clean lift is achieved assistance will be required to steady the canopy during removal.

5.7 Canopy - Fuel Tank Removal

To remove the fuel tank proceed as follows:

1. With the canopy removed it will now be necessary to remove the core build from the base. Begin by removing the fasteners from the base anti vibration mountings.
2. Disconnect the air pump silencer hose from the discharge elbow of the air pump. Remove the clamps holding silencer body. Remove the air pump silencer assembly complete.
3. With the anti vibration mounts released attach chains to the four corner lifting eyes on the base chassis. Lift the core build clear of the trailer and base and set down on suitable supports to allow draining of the fuel tank.
4. Release both of the fuel lines from the tank.
5. Slacken and remove the four nuts and washers holding the tank, once the fuel is drained and assistance is available to help support the tank.
6. With nuts and washers removed, the tank should lower away clear of the chassis.

5.8 Canopy – Fuel Tank Refitting

To refit the fuel tank proceed as follows:

1. Refit the tank as per removal taking note of the fuel filter position if the cover plate has previously been removed to aid cleaning. Apply new gaskets throughout to prevent future leakage.
2. With assistance, lift tank into position and secure to the chassis. Tighten nuts in turn and reconnect fuel lines.
3. If the base drain plug has been removed and while the core assembly is out, part fill the tank with fuel to check that the base drain plug seals correctly.
4. Reverse instructions for canopy removal and test unit.

5.9 Pump removal

1. Remove fixings securing pump to engine flywheel housing. Slacken and remove the four M16 fixings holding the pump body. Support engine flywheel housing. Attach a suitable lifting device to the pump and manually draw the pump backwards off of the coupling pins. When the pins are clear of the rubber element lift the pump unit clear of the chassis.

5.10 Engine removal

2. To remove the engine the following parts will need to be removed from the tank/trailer structure and where necessary tied back to the engine to prevent damage. Disconnect and drain fuel lines. Undo and remove control panel from bracket. Tie the hose back to a suitable point on the engine.
3. Remove fixings securing pump to engine flywheel housing.
4. The last fixings to be removed are engine mount to AV mount securing screws. Slacken and remove each in turn.
5. The engine is now ready to be removed from the base chassis structure. Pull the engine off of the pump bell housing register and off the coupling element until the pins of the coupling are clear. Lift vertically up and away. Watch for any danger of collision between engine and pump unit if still in place. The engine will need to be placed in a suitable frame to prevent damage to the oil drain or sump.

5.11 Engine & pump re-fitment

1. Before refitting the pump unit, position the hub and rubber element onto the pump shaft, to position marked when removing, and tighten six capscrews in hub taper locking ring to torque specified. Lift pump onto saddle plate and finger tighten A/V mount bolts.
2. Lift the engine and push the coupling drive pins into the rubber element on the pump shaft. Push engine forward until it locates on pump bell

housing. Insert and tighten all fixings securing engine to pump. Finger tighten A/V mounts bolts.

3. Reconnect all fuel lines, oil drain and refit the control panel.
4. The pump should now be tightened down to 150 Nm.
5. Tighten the four engine mount screws.

5.12 Canopy – Canopy Refitting

To refit the canopy proceed as follows:

1. Re-sling the canopy as for removal and lift into position. Take care not to damage the radiator when positioning. Lower onto skid base checking for alignment of the lifting eye brackets.
6. When down and before fitting any fixings check that the radiator overflow pipe is not trapped by the canopy bulkhead. Release if trapped.
7. Refit canopy lifting fasteners nuts and base corner fixing screws. Adjust alignment if necessary and tighten lifting eye fasteners then corner screws.
8. Refit the delivery fitting and refit the suction and discharge covers as the reverse of removal.
9. Reconnect the exhaust extension and refit insulating cover.
10. Reconnect the emergency stop wiring and refit the battery assembly.
11. Fill with fuel and bleed the system as required. Test run. Inspect all fasteners after 50 hours of running.

6 WORKSHOP TOOLS

Major Servicing will always be carried out more quickly by the use of the following special tools and procedure. More importantly, their use will help to ensure that new components are not damaged whilst being fitted.

The tools are simple to employ and have been designed for use in combination with standard fitter's tools. For some operations, a simple press, and a bench complete with a vice will be desirable.

We earnestly advise all pump users to purchase a complete set of tools.

6.1 Care of Servicing Tools

Always clean, oil and safely store tools after use.

Complete sets of tools are available by quoting:

Part No. 1590160000 - Selwood D150R

Comprising:

Shaft Spanner – Air pump	1599318000	1
Mechanical Seal Fitting Tool	1596131000	1
Impeller Spacer Removal Tool	1590170000	2
Drive Rod Bearing Drift	0015168000	1
Mechanical Seal Seat Removal Tool	0015166000	1
Drive Rod Seal Tool	0010103000	1
Con Rod Seal Installation Tool	0015102000	1
Drive Rod Installation Tool	0015101000	1
'C' Spanner HN11	1590185000	1
'C' Spanner HN5	1590180000	1

Optional Tools

Bearing setting jig WRS987 -1 off

Oil Injection Pump SKF 729124 - 1 off

7 USE OF SERVICE TOOLS

7.1 Fitting of Actuator Neck Seal

1. Lightly clamp seal installation tool against end of drive rod by means of capscrew, as shown.
2. Push seal into rear of inner pump body recess (Part No 0015014000).
3. Clean exposed shaft and tool surfaces, and smear with soft soap. Carefully slide the actuator neck seal onto shaft until it abuts against the conical shoulder.

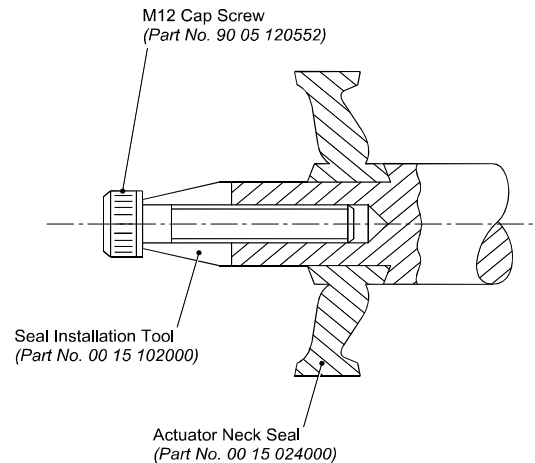

7.2 Removal of Mechanical Seal Stationary Seat and Joint Ring

1. Ensure oil is drained from mechanical seal chamber. Remove impeller and spacer, complete with rotating mechanical seal components.
2. Engage tip of removal tool on inside face of seat. Remove seat by pulling evenly at several peripheral points.
3. Joint ring can then be collapsed and discarded.

See Section 7.8 for installation.

IMPORTANT ADVICE



New Mechanical Seal Components must be handled with great care. In particular, the seal faces must not be touched by hand and must only come into contact with clean soft paper that is free from abrasive materials. Premature seal failure is likely to occur if this advice is not heeded.

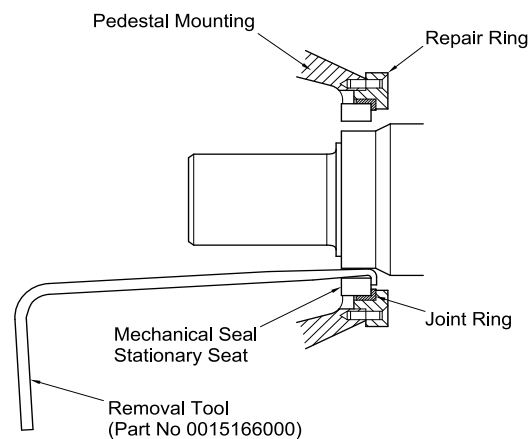

7.3 Removal of Linear Bearing Seal Assembly

1. Remove internal circlip with suitable pliers and remove seal assembly by carefully tapping with blunt punch or drift from bush end.
2. Replacement of all components may be aided by smearing adjacent surfaces with soft soap.
3. Prior to sliding home the drive rod seal carrier (Part No. 1589100000), wiper seal (Part No. 9140035070) **must first** be assembled together, using insertion tool Part No. 0010103000. Carefully applied pressure from a hand press or vice jaws may be employed for this operation.



IMPORTANT ADVICE

Parts must be assembled in correct order and orientation.

4. Great care must be exercised when replacing the circlip to ensure that the lip of the wiper seal is not damaged by the handtools used.

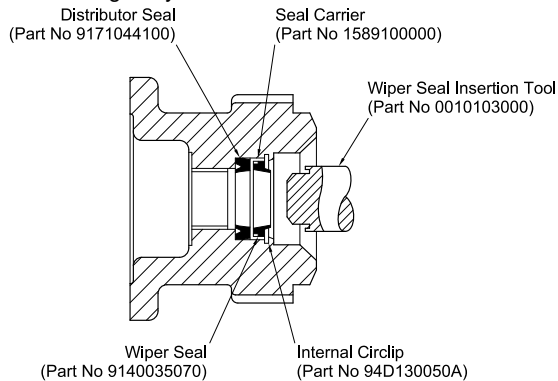

7.4 Fit Air Pump Pedestal with Seals to Air Pump Bearing Housing

1. Thoroughly clean exposed drive rod surfaces and position installation tool as shown.
2. Smear tool and drive rod surfaces with oil.
3. Thoroughly lubricate drive rod bearing and drive rod seal with oil and fit new gasket before pushing pedestal seal housing assembly along drive rod until it registers in bearing housing.

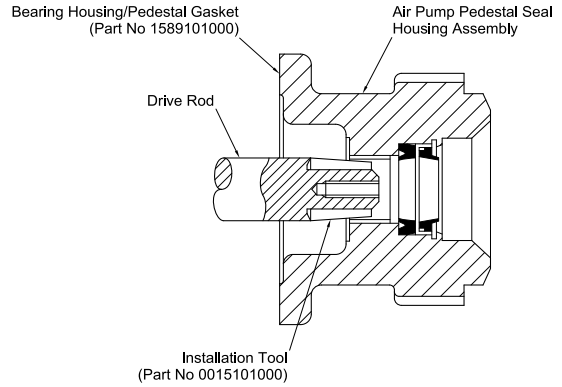

7.5 Remove Pedestal Bush

4. Insert shouldered end of drift into bush as shown in upper sketch.
5. Support air pump pedestal evenly on face 'X' leaving sufficient clearance for bush to emerge freely.
6. Push out bearing bush by pressing or striking on tool face 'Y'.

7.6 Fit New Pedestal Bush

1. Position seal housing on clean flat surface and register new bush in bore as shown in lower drawing.
2. Lightly oil bore and bush to prevent pick up.
3. Insert shouldered end of drift into bush as shown in lower sketch.
4. Insert bush by pressing or striking on tool face 'Y' until end of bearing is flush with face 'X'.

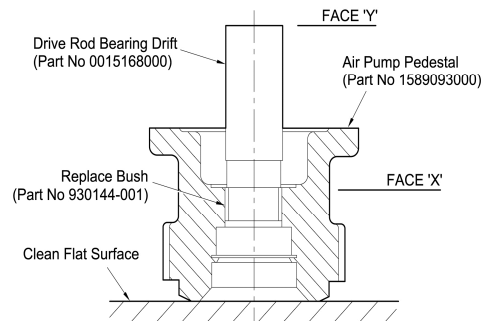
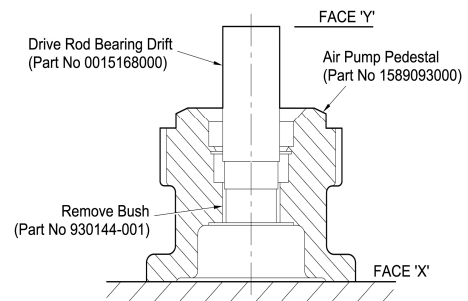

7.7 Impeller Spacer Removal

1. Thoroughly clean exposed shaft surfaces and smear with oil.
2. Insert the two impeller spacer removal tools into the semi-circular holes in the front face of the impeller spacer and turn downwards to lock inside.
3. Then pull evenly on both tools to remove impeller spacer from shaft.

IMPORTANT ADVICE



New Mechanical Seal components must be handled with great care. In particular, the seal faces must not be touched by hand and must only come into contact with clean soft paper that is free from abrasive materials. Premature seal failure is likely to occur if this advice is not heeded.

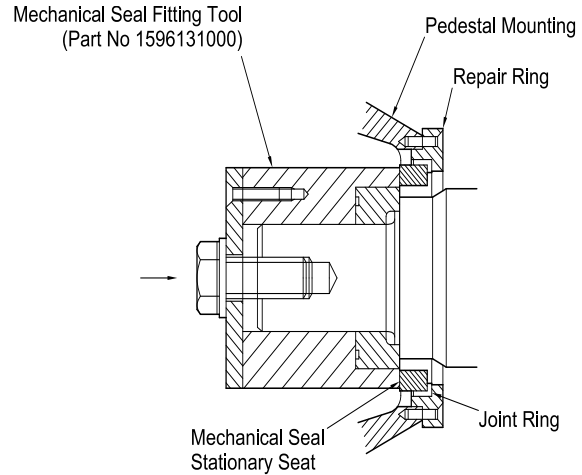
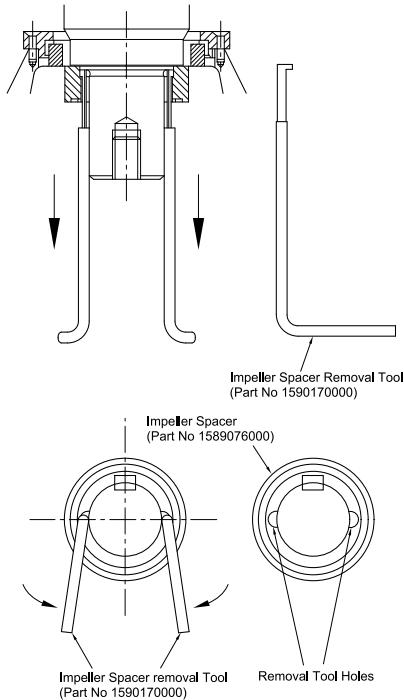

7.8 Fit New Mechanical Seal Stationary Seat and Joint Ring

1. To replace the mechanical seal and joint ring they must be assembled together with outer face of joint ring smeared with soft soap.
2. Offer up to recess in repair ring of pump pedestal and gently press home using mechanical seal fitting tool 1596131000.

8 FAULT FINDING GUIDE

This table gives the most common symptoms arising in connection with water handling duties. Please consult Selwood Pumps for further advice if the service fault is not described, and particularly if the duty has uncommon characteristics.

At no time should the pump be run if its bearing housing or flushing chamber contains contaminated oil. Very small volumes of oil may be lost from these chambers during a day's normal running, but remedial action should immediately be taken if the loss becomes excessive. The most likely causes of failure are given in the sequence in which they should be investigated. For example, if the pump will not prime, carry out the first service instruction that is listed and proceed to the second only if the first proves to be inappropriate.

PUMP WILL NOT PRIME, OR LOSES PRIME HAVING PUMPED PRODUCT FOR A BRIEF PERIOD OF TIME

ACTION	COMMENT
1 Check that drain taps fitted to volute and air pumps are closed.	Drain taps are sometimes left open overnight. If okay, try Action 2.
2 Remove inspection cover and check that delivery valve is seating efficiently.	The delivery line MUST BE DRAINED before the cover is removed. If okay, try Action 3.
3 Disconnect hose from air pump spigot and attach vacuum gauge to pump - should read 29" H ₂ O (25.6" Hg) or more, after the pump is stopped.	If vacuum is okay, check Action 4. If vacuum is low or fails quickly, check Action 8.
4 Reconnect air pump hose, and check vacuum at suction spigot of main pump. Correct reading is given above.	If vacuum is okay, check Actions 5(a) and (b). If vacuum is slow to rise or low, check Actions 6 and 7.
5 (a) Check all suction side hoses, fittings and joints for air leaks.	Priming problems are VERY often caused by faults in supply pipework. Air must not be allowed to pass into the system across couplings, etc.
(b) Check strainer and suction hose for blockages.	Do not use non-reinforced hose. Always fit a strainer of correct size and type.
6 Examine separator assembly for air leaks or trapped solids. Check peel valve seat for ice in cold conditions.	Refer to Section 5.2 Separator Maintenance for instructions. The float must be able to rise and fall freely. The peel valve must completely shut off the air pump when the float rises to its maximum position.
7 Check level of oil in mechanical seal chamber.	If level is very low, mechanical seal may be admitting air. Top up, and re-check vacuum. Substantial oil loss or chamber is full of water indicates seal failure - refer to Section 5.3.3 Mechanical Seal for instructions.
8 Examine valves and flexing seals in air pump assembly and check that castings are not cracked.	Refer to Section 5.1 Air Pump Maintenance for instructions.
9 Examine toothed belt for wear or damage.	Refer to Section 5.1.11 Drive Belt for instructions.
10 Examine drive coupling for wear and damage.	Refer to Section 1.5 Fitting Instructions for Centaflex Couplings (Diesel Engines) for instructions.
11 Check impeller and front and rear wear plates for excessive wear or damage.	Refer to Section 5.3.1 Impeller and Sections 5.3.4 Front Wear Plate and 5.3.5 Rear Wear Plate .

OUTPUT AND HEAD ARE LESS THAN PUBLISHED FIGURES

ACTION	COMMENT
1 Check strainer and suction pipework for blockages. Also check that air is not being pulled through a vortex created in the supply reservoir.	Choking of the supply system by solids will increase the flow resistance, thus increasing the head against which the pump has to operate, and so reducing output. The entry of air through faulty pipe joints will have a similar effect. Reduction also occurs if air is entrained through a vortex - to eliminate, increase strainer's submergence.
2 Check pump speed with tachometer.	Speed, off load must not exceed 1800rev/min.
3 Check that delivery valve, discharge branch of	Obstructions downstream of the pump will increase the

	casing, and pipework are free from blockages.	flow resistance and thus reduce output.
4	Check condition of impeller.	Excessively worn vanes will reduce output. Also check outside diameter of vanes: Standard D150R Dia.= 240mm Contact Selwood with pump number to confirm correct impeller variant fitted.
5	Check condition and clearances of wear plates with impeller.	Excess wear enlarging clearances between wear plates and impeller vanes will reduce out. Refer to Section 5.3.2 Setting Impeller Clearances
6	Check system head is greater than anticipated.	Connect pressure gauges to suction and discharge at pump. Calculate pressure generated and refer to performance curve for flowrate.
7	Pump drives in wrong direction.	Impeller rotates anti-clockwise viewed from suction end of pump.
8	Insufficient NPSH available.	Calculate NPSH available and compare with NPSH required on pump performance curve.

LIQUID IS BEING PUMPED OUT OF AIR PUMP, I.E. WATER CARRYOVER IS OCCURRING

ACTION	COMMENT
1 Check condition of separator assembly.	No significant amounts of water should normally pass across the air pump. The rubber peel valve may not be seating correctly, the float may be punctured, or not be able to rise and fall freely, etc. Also, check that bush is correctly positioned. Refer to Section 5.2 Separator Maintenance for instructions.
2 Check condition of valves and flexing seals in air pump.	On rare occasions, malfunction of the air pump seals In air pump can cause the separator float to move erratically. Refer to Section 5.1 Air Pump Maintenance for instructions.

WATER/OIL LEAKING OUT OF MECHANICAL SEAL CHAMBER FROM BREATHER, OR FROM DRAIN HOLE BETWEEN 3/8" BSP PLUGS BENEATH BEARING HOUSING

ACTION	COMMENT
1 Drain mechanical seal chamber to check contents.	The chamber should only contain oil. If the mechanical seal has failed, water may be present in the chamber. If so, replace seal in accordance with instructions given in Section 5.3.3 Mechanical Seal.

OIL LEAKING FROM AIR PUMP BEARING HOUSING

ACTION	COMMENT
1 Check that air pump reservoir has not been overfilled with oil.	It is extremely difficult to overfill air pumps built to latest specifications.
2 Check conditions of air pump drive rod and associated seal.	Refer to Section 5.1 Air Pump Maintenance for instructions.

MAIN PUMP BEARINGS RUNNING HOT – IE IMPOSSIBLE TO MAINTAIN HAND CONTACT ON HOUSING

ACTION	COMMENT
1 Check grease is not over packed in bearings.	Grease should only just cover rollers of the bearings. Refer to Section 5.4.3 Bearings for instructions.
2 Check that grease is the correct grade and not contaminated.	If the incorrect grade of grease is used or grease becomes contaminated it can cause excessive wear to bearings. To avoid this strip out bearing housing, remove grease and re-pack bearings with the correct grade. Refer to Section 5.4.3 for instructions.

- | | | |
|---|------------------------------------|---|
| 3 | Check air pump belt drive tension. | Over tension drive belts can load the pump bearings unnecessarily. To check belt drive tension refer to Section 5.1.12 Drive Belt Tension for instructions. |
|---|------------------------------------|---|

PUMP CANNOT BE ROTATED BY HAND BY MEANS OF STARTING HANDLE, FOR EXAMPLE

ACTION	COMMENT	
1	Check for ice in air pump or volute.	In cold weather, ice can form in these chambers if they have not been drained. Eliminate by means of hot water.
2	Check that air pump assembly is not faulty.	The actuator must be securely fastened to its drive rod, and must be able to reciprocate freely without touching any stationary surface. Refer to Section 5.1 Air Pump Maintenance for instructions.
3	Check that impeller and drive shaft are free to rotate.	Although unlikely, it is possible for fibrous solids to restrict the impeller's movement. Also, failure of the drive shaft bearings may have resulted in the impeller striking the casing. Seizure of the bearings could also produce the problem. Refer to Section 5.3 Impeller, Mechanical Seal, Wear Plate and Delivery Valve Maintenance for instructions.

PUMP PRODUCES UNEXPECTED NOISES WHEN RUNNING

ACTION	COMMENT	
1	Check quality and quantity of oil in mechanism chamber and flushing chamber.	Incorrect volume and quality may result in overheating as well as abnormal noise. Note that extensive running under such circumstances can significantly damage pump components.
2	Check that air pump assembly is not faulty.	The actuator must be securely fastened to its drive rod, and must be able to reciprocate freely without touching any stationary surface. Refer to Section 5.1 Air Pump Maintenance for instructions.
3	Check that air pump mechanism is not faulty.	Excessively worn connecting rod bearings, or an undersized eccentric or fulcrum pin, could cause this problem. Refer to Section 5.1 Air Pump Maintenance for instructions.
4	Check fastener torque a) Pump b) Engine c) Fuel tank d) Axles	Loose fasteners produce noise if not sufficiently tightened.
5	Examine impeller and wear plate clearances.	Refer to Section 5.3.1 Impeller and Sections 5.3.4 Front Wear Plate and 5.3.5 Rear Wear Plate .
6	Check NPSH available against NPSH required and reduce suction head if necessary.	Causes cavitation within pump
7	Check for blockage in suction.	Causes cavitation within pump
8	Check noise from bearing housing and temperatures. Also check condition of oil in air pump bearings.	This could be evidence of damaged bearings. Refer to Section 5.4.3 Bearings for instructions.

Refer to Selwood Ltd if the above advice does not solve your problem.

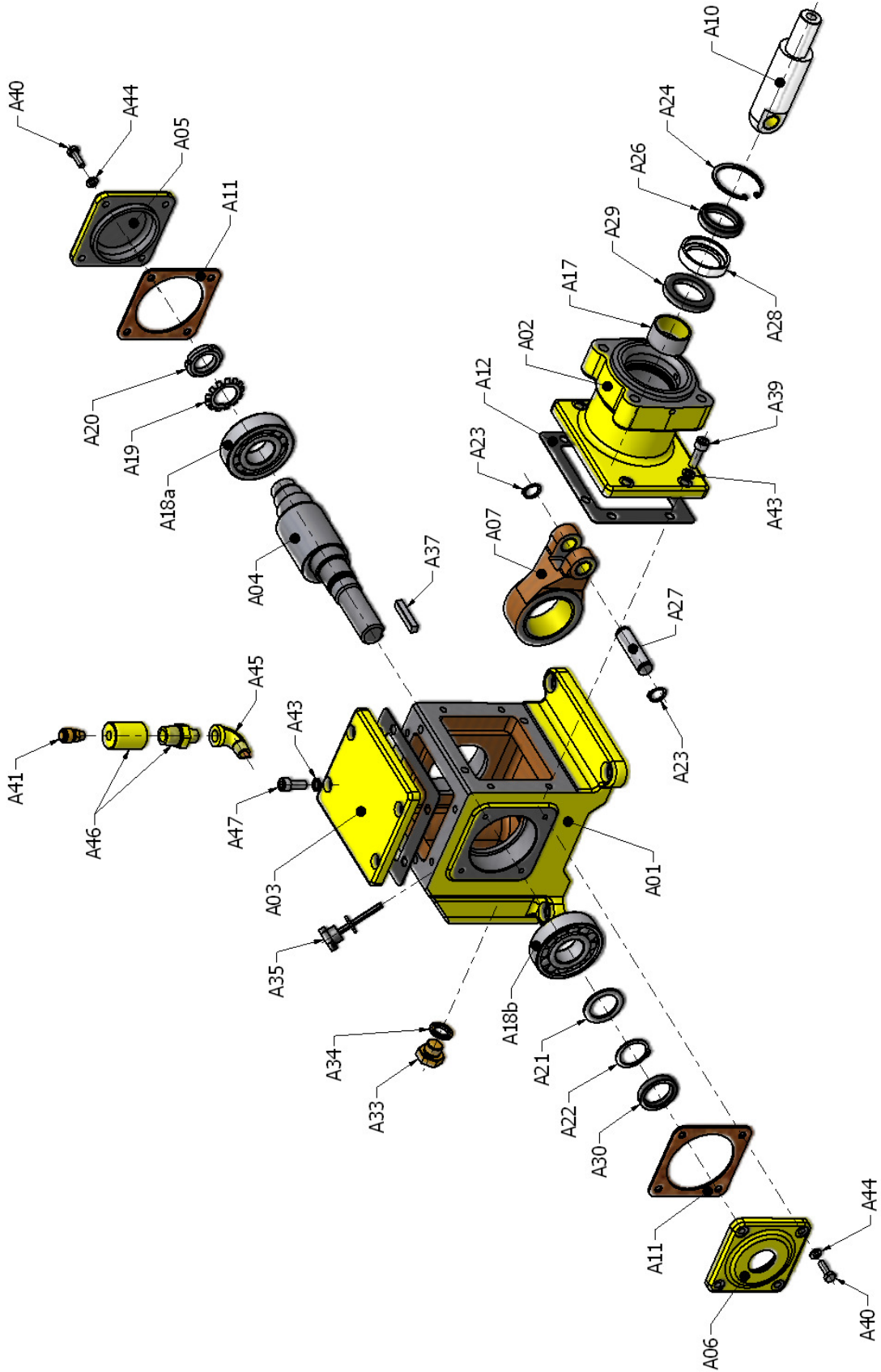

9 PARTS LIST

9.1 Air Pump Drive Assembly 1502021000

ITEM	DESCRIPTION	PART NUMBER	QTY
A01	Air Pump Bearing Housing	1501132000	1
A02	Air Pump Pedestal	1589093000	1
A03	Cover Plate	1589097000	1
A04	Air Pump Drive Shaft	1589088000	1
A05	Air Pump Drive Bearing Cap	1589096000	1
A06	Air Pump Drive End Cap	1589095000	1
A07	Air Pump Connecting Rod Assembly	1589102000	1
A10	Air Pump Drive Rod Assembly	1589103000	1
A11	Gasket - End Cap	1589098000	2
A12	Gasket - Bearing Housing/Pedestal	1589101000	2
A17	Pedestal Bush	930144-001	1
A18A	Cylindrical Roller Bearing NUP306	930110-002	1
A18B	Cylindrical Roller Bearing N306	930110-001	1
A19	Lock Washer	930090-001	1
A20	Bearing Lock Nut	930090-002	1
A21	Bearing Support Washer	930190-001	1
A22	External Circlip 30 Dia Shaft	94D140030A	1
A23	External Circlip 15 Dia Shaft	9401000151	2
A24	Internal Circlip 50 Dia Bore	94D130050A	1
A26	Wiper Seal	9140035070	1
A27	Fulcrum Pin	1589094000	1
A28	Seal Carrier	1589100000	1
A29	Distributor Seal, Internal	9171044100	1
A30	Oil Seal 28 I/D	910110-001	1
A31	Oil Check Label	0015229000	1
A32	Hammer Drive Screw No.2 x 14"	9045002259	2
A33	Plug (Oil Level and Drain),W8" BSP	9534M00302	1
A34	Sealing Washer 3/8" BSP	9534M00301	1
A35	Oil Plug Dipstick	1501221000	1
A37	Rect. Parallel Key 8 x 7 x 40 Square Ends	9000099-02	1
A39	M8 Hex. Soc. Cap Screw x 25 lg	9005080250	4
A40	M6 Hex. Hd. Setscrew x 20 lg	9000060201	8
A41	Breather Valve 1/8" BSP	9528001000	1
A43	M8 Sq. Sect. Spring Washer	9000879-01	8
A44	M6 Rect. Sect. Spring Washer	9030060229	8
A45	90° Male/Female Elbow - Modified	9515P00201	1
A46	Air Pump Breather Extension	9528P00201	1
A47	M8 x 20 Hex. Socket Cap Screw	9005080200	4

When ordering spares, please state:

PUMP NUMBER - PART NUMBER - DESCRIPTION OF PART

A drive rod kit is available under part number 15..... consisting of A10, A17, A24, A26, A28, A29

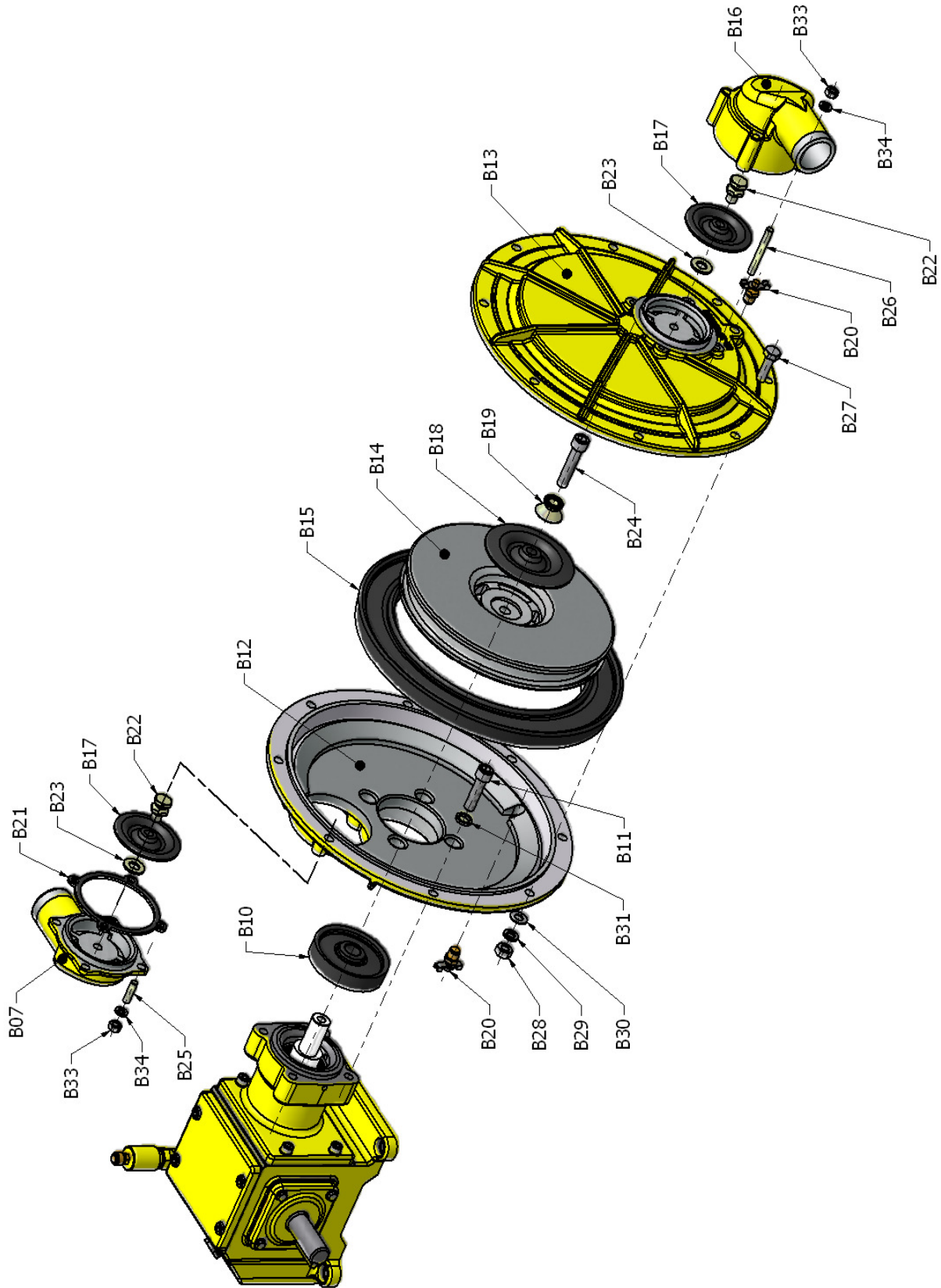

9.2 Air Pump Parts 1502021000

ITEM	DESCRIPTION	PART NUMBER	QTY
B07	Suction Valve Box	0015017000	1
B10	Actuator Neck Seal	0015024000	1
B11	Cap Screw M12 x 45	9001240-01	4
B12	Inner Pump Body	0015014000	1
B13	Outer Pump Body	0015015000	1
B14	Actuator	0015016000	1
B15	Actuator Seal	0015023000	1
B16	Exhaust Valve Cover	1592306000	1
B17	Suction and Delivery Valve	0015021000	2
B18	Actuator Valve	0003221200	1
B19	Actuator Capscrew	0015975000	1
B20	Drain Tap	9520103000	2
B21	Suction Valve Box Gasket	0015022000	1
B22	Valve Stud	0015019000	2
B23	Valve Washer	0002068000	2
B25	M8 Stud	9035080204	4
B26	M8 Stud	9035080554	4
B27	Hex. Hd. Bolt M10 x 35	9001100351	8
B28	Full Nut M10	9025100004	8
B29	Spring Washer M10	9030100229	8
B30	Washer M10	9030100024	8
B31	Cap Screw Washer	0015100000	4
B33	Full Nut M8	9025080004	8
B34	Spring Washer M8	9030080229	8

When ordering spares, please state:

PUMP NUMBER - PART NUMBER - DESCRIPTION OF PART

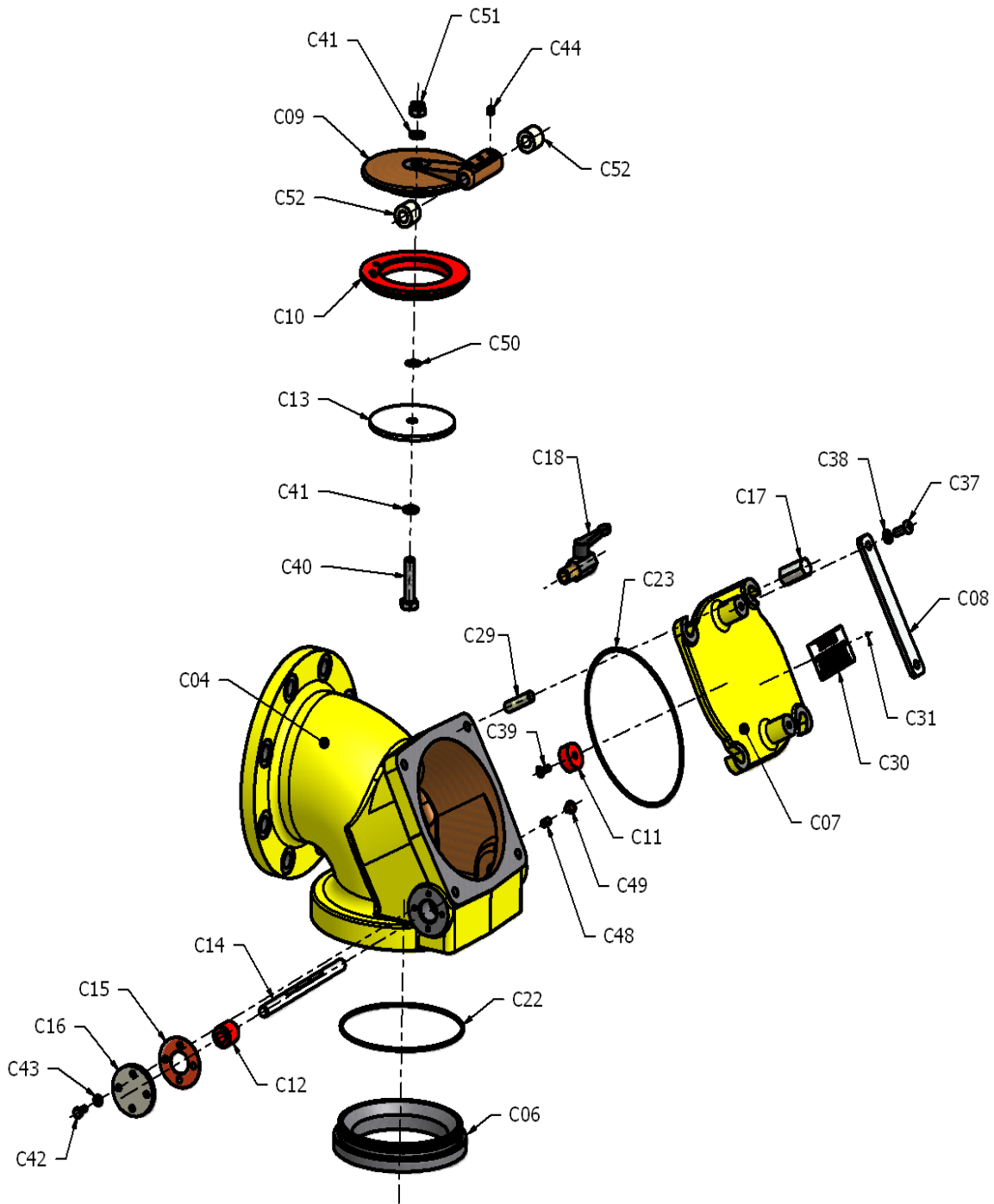

9.3 Delivery Valve Parts 1589107000

ITEM	DESCRIPTION	PART NUMBER.	QTY
C04	Delivery Valve Body	1589124000	1
C06	Valve Seat	1589126000	1
C07	Inspection Cover	1589127000	1
C08	Handle	1589136000	1
C09	Valve (Hinged)	1595269000	1
C10	Valve Insert	1589129000	1
C11	Valve Stop	1589130000	1
C12	Bush	1589128000	2
C13	Retaining Plate	1595272000	1
C14	Pivot Pin	1589131000	1
C15	Gasket, Pivot Cap	1589133000	2
C16	Pivot Cap	1589132000	2
C17	Hex. Nut Long	1589135000	4
C18	Drain Tap 3/8" BSP	9520003000	1
C22	'O' Ring Gaco RM 1795-30	910600-001	1
C23	'O' Ring Gaco RM 2095-30	910700-001	1
C29	M 12 Stud x 30 lg BS4439	9001250-01	4
C30	Warning Label	1589137000	1
C31	Hammer Drive Screw	9045002259	2
C37	M8 Socket Button Hd. Screw x 20 lg	9000840-02	2
C38	M8 Rect. Sect. Spring Washer	9030080229	2
C39	M6 Socket CSK Hd. Screw x 16 lg St. Steel	9000647-01	1
C40	M12 x 45 Hex Hd Bolt	9001120451	1
C42	M6 Hex. Hd. Setscrew x 16 lg	9000630-01	8
C43	M6 Rect. Sect. Spring Washer	9030060229	8
C44	M8 Socket Setscrew 'W' Point x 8 lg St. Steel	9000847-01	3
C48	M8 Socket Setscrew 'W' Point x 12 lg	9000840-01	1
C49	Tapered Protection Plug	9522M00801	1
C50	Star Lock Washer	9001277-02	1
C51	M12 Hex Self Locking Nut	9025120344	1
C52	Spacer Bush	1594116000	2

When ordering spares, please state:

PUMP NUMBER - PART NUMBER - DESCRIPTION OF PART

9.4 Bearing Housing Assembly 1509295000

ITEM	DESCRIPTION	PART NUMBER	QTY
D01	Bearing Housing	1509296000	1
D02	Front End Cover	1589083000	1
D03	Drive End Cover	1589074000	1
D04	Drive Shaft	1589085000	1
D07	Gasket - Drive End Cover	1589079000	2
D08	Spacer Pulley	1589106000	1
D09	Drive Shaft Collar	1589075000	1
D10	Single Row Taper Roller Bearing SKF31311-B	930220-001	2
D12	Anti-Friction 'V' Seal	910240-001	1
D13	Oil Seal Gaco DPSM 709010	910210-001	2
D20	3/8" BSP Drain Plug	9534M00302	1
D21	3/8" BSP Sealing Washer	9534M00301	3
D22	1/8" BSP Taper Plug	9522001000	3
D23	1/8" BSP Straight Grease Nipple	9580P00101	1
D27	External Circlip 75 Dia Shaft	94D140075A	1
D30	M8 Hex. Socket Setscrew x 12 lg 'W' Point	9000840-01	2
D31	Key - Rect. Parallel 12 x 8 x 50 square ends	9041125013	1
D32	Key - Rect. Parallel 12 x 8 x 86 square ends	9000099-01	1
D34	Hex. Hd. Setscrew M6 x 20	9000060201	12
D36	Spring Washer M6	9030060229	12
D39	Tapered Protection Plug 1/4" BSP	9522P00201	1
D47	Vented Taper Plug - 3/8" BSP	1590256000	1
D55	Male 3/8" BSP-3/8" Male Union Adaptor	9517P00305	2
D56	Male 1/4" BSPT-1/4" Male Union Adaptor	9517P00304	1
D57	Breather Hose Assembly	1501313000	1
D58	Connector- Exp. 1/8"BSPT – 1/8"BSPP Female	9517P00101	1

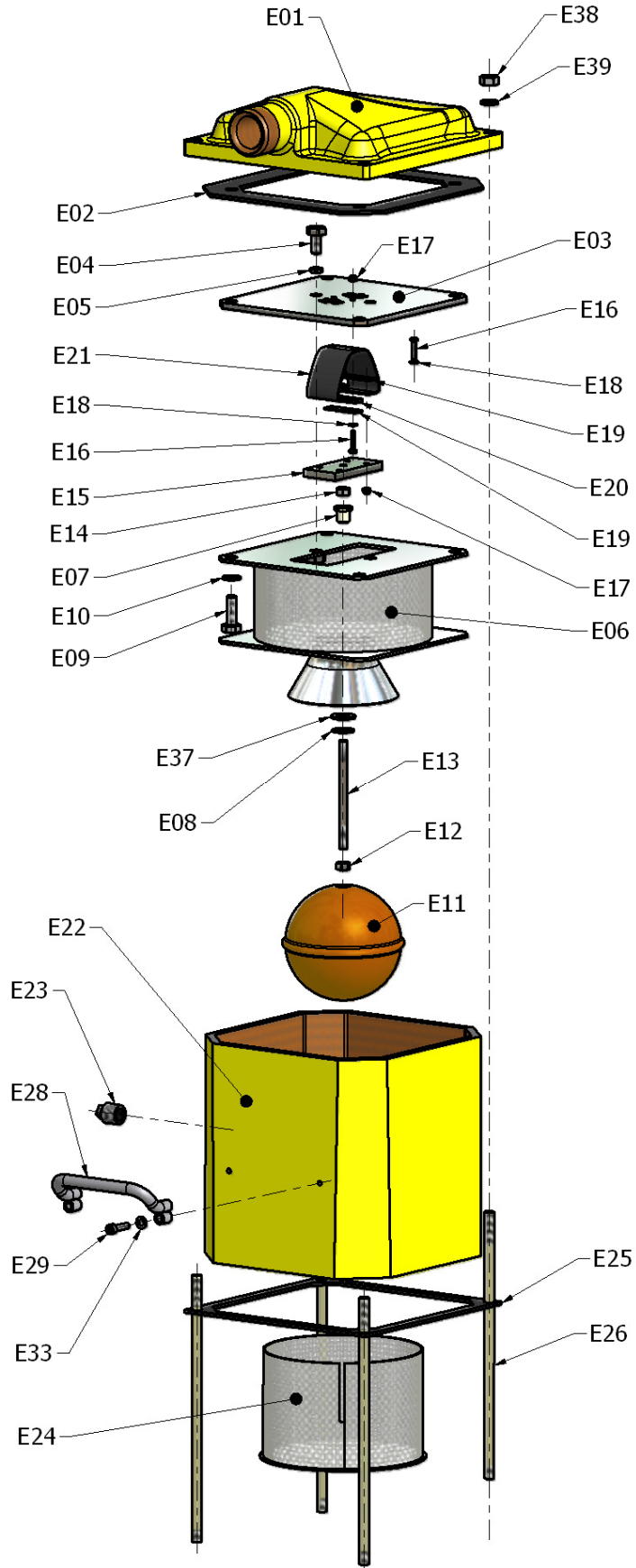

9.5 Separator Parts 1589162000

ITEM	DESCRIPTION	PART NUMBER	QTY
E01	Separator Cap	0015034000	1
E02	Separator Cap Gasket	0015043000	1
E03	Port Plate	0015036030	1
E04	Hexagon Head Screw M 10 x 20 S.S.	9000100207	2
E05	Sealing Washer M10	9030100289	2
E06*	Upper Diffuser Sub-Assembly	0015037000	1
E07	Upper Diffuser Bush	0015160000	1
E08	Upper Diffuser Bush Clip	9030130407	1
E09	Hexagon Head Screw M10 x 30 S.S.	9000100307	4
E10	Spring Washer M10 S.S.	9030100207	4
E11	Float	9565001000	1
E12	Full Nut 5/16" BSW S.S.	0006741030	1
E13	Operating Rod	0015090000	1
E14	Full Nut M8 S.S.	9025080007	1
E15	Operating Plate	0015085000	1
E16	Slotted Head Screws M4 x 20 S.S.	9018040207	6
E17	Locking Nut M4 S.S.	9025040307	6
E18	Washer M4 S.S.	9030040027	6
E19	Clamp Bar	0015084000	3
E20	Clamp Bar Seal	0015183000	1
E21	Peel Valve Rubber	0015039000	1
E22	Separator Body	0015033000	1
E23	Plug 1/2" BSPT	9522004000	1
E24	Lower Diffuser	0015038000	1
	Lower Diffuser – Stainless steel	0015038100	1
E25	Separator Body Gasket	0015044000	1
E26	Tie Rod	0015045000	4
E28	Separator Handle	1507264000	2
E29	Hex Skt Cap Screw M6x25 LG	9005060250	4
E33	Plain Washer M6	9030060024	4
E37	Washer - Nitrite	1590049000	1
E38	Full Nut M10	9025100004	4
E39	Spring Washer M10	9030100229	4

* Sub-assembly E06 includes E07 and E08 and E37

Items E05, E07, E08, E16, E17, E18, E20 and E21 are available as spares kit 0015996000

When ordering spares, please state:

PUMP NUMBER - PART NUMBER - DESCRIPTION OF PART

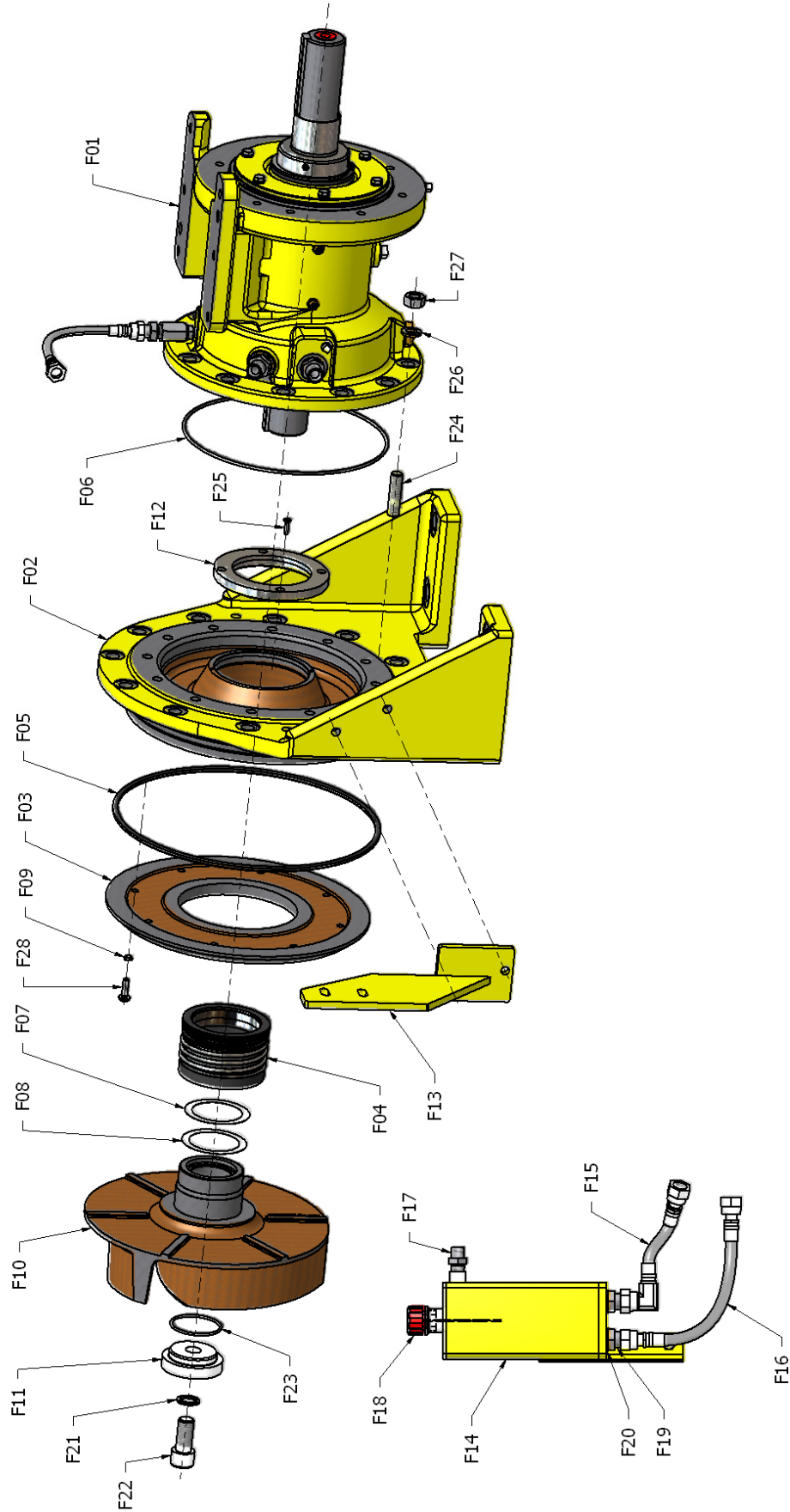

9.6 Bearing Housing and Pedestal Assembly

ITEM	DESCRIPTION	PART NUMBER	QTY
F01	Bearing Housing Assy	1509295000	1
F02	Mounting Pedestal	1589071000	1
F03	Rear Wear Plate	1509310000	1
F04	Mechanical Seal Assy	1589108000	1
F05	'O' Ring Gaco RM 2693-57	910800-003	1
F06	'O' Ring Gaco RM 2095-30	910800-001	1
F07	Impeller Shim – 0.25mm Thk	1589077000	A/R
F08	Impeller Shim – 0.10mm Thk	1589078000	A/R
F09	Seal Washer M6 PSM Nyltite	9000679-01	8
F10	Impeller 231mm Dia.	1511055000	1
F11	Impeller Collar	1589091000	1
F12	Repair Ring	1595129000	1
F13	Oil Reservoir Support Bracket	1501308000	1
F14	Oil Reservoir	1501307000	1
F15	Oil Feed Hose Assy – Short	1501310000	1
F16	Oil Feed Hose Assy – Long	1501311000	1
F17	Male 1/4" BSPT – 1/4" Male Union Adaptor	9517P00304	1
F18	Breather Plug with Dipstick	7598305000	1
F19	Male 3/8" BSP – 3/8" Male Union Adaptor	9517P00305	2
F20	3/8" BSP Sealing Washer	9534M00301	2
F21	Bonded Seal M16 Stainless Steel	9001677-01	1
F22	M16 Hex. Socket Cap Hd Screw x 35 lg	9001647-01	1
F23	'O'Ring Gaco RM 0496-24	910100-001	1
F24	M12 Stud x 35 lg BS4439	9001250-06	12
F25	Csk Hd Screw M4 x 16 lg	9000440-03	4
F26	Spring Washer M12	9030120229	12
F27	Hex Full Nut M12	9025120004	12
F28	Cheese Hd Screw (Slotted) M6 x 20 lg	9000697-01	8

When ordering spares, please state:

PUMP NUMBER - PART NUMBER - DESCRIPTION OF PART

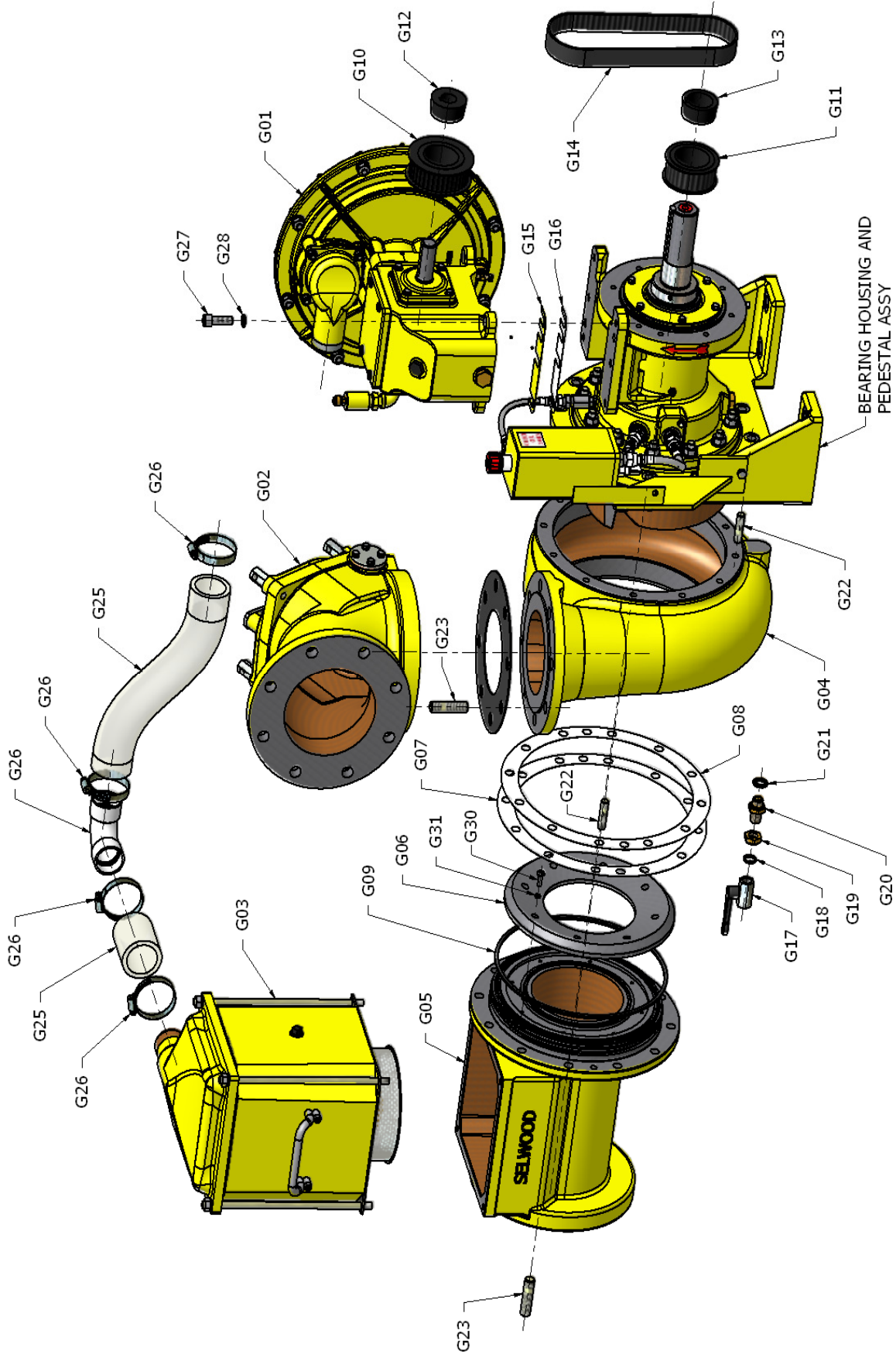

9.7 D150 Pump Unit

ITEM	DESCRIPTION	PART NUMBER	QTY
G01	Air Pump and Drive Assy	1502021000	1
G02	Delivery Valve Assy	1589107000	1
G03	Seperator Assy	1589162000	1
G04	Volute Casing	1589087000	1
G05	Suction Tube	1589090000	1
G06	Front Wear Plate	1589073000	1
G07	Shim Suction Tube – 0.25mm Thk	1589081000	A/R
G08	Shim Suction Tube – 0.15mm Thk	1589082000	A/R
G09	'O'Ring Gaco RM 3393-57	910800-003	1
G10	HTD Pulley 38-8M-20	9633M09502	1
G11	HTD Pulley 34-8M-20	9633M08502	1
G12	Taper Lock Bush 1610-25	9631M02505	1
G13	Taper Lock Bush 1610-42	9631M04201	1
G14	HTD Belt 720-8M-20	9641M72004	1
G15	Shim Solid 0.5mm Thk	1589141000	A/R
G16	Shim Solid 0.25mm Thk	1589142000	A/R
G17	Drain Tap 3/8" BSP	9520003000	1
G18	Hobbs Seal 3/8"	9534M00303	1
G19	Hobbs Coned Locknut 3/8"	9534M00304	1
G20	Straight Hobbs Connector 3/8"	9534M00305	1
G21	Bonded Washer 3/8"	9534M00301	1
G22	Stud M12 x 35 lg	9001250-06	24
G23	Stud M16 x 45 lg	9001650-01	16
G25	Suction Hose 50mm ID	9542000000	1m
G26	Hose Clip	9505007004	4
G27	Hex Socket Cap Hd Screw M12 x 35 lg	9005120350	4
G28	Spring Washer M12	9001279-01	4
G30	M6 Cheese Hd (Slotted) Screw x 20 lg	9000697-01	8
G31	M6 Seal Washer PSM Nytlite	9000679-01	8

When ordering spares, please state:

PUMP NUMBER - PART NUMBER - DESCRIPTION OF PART

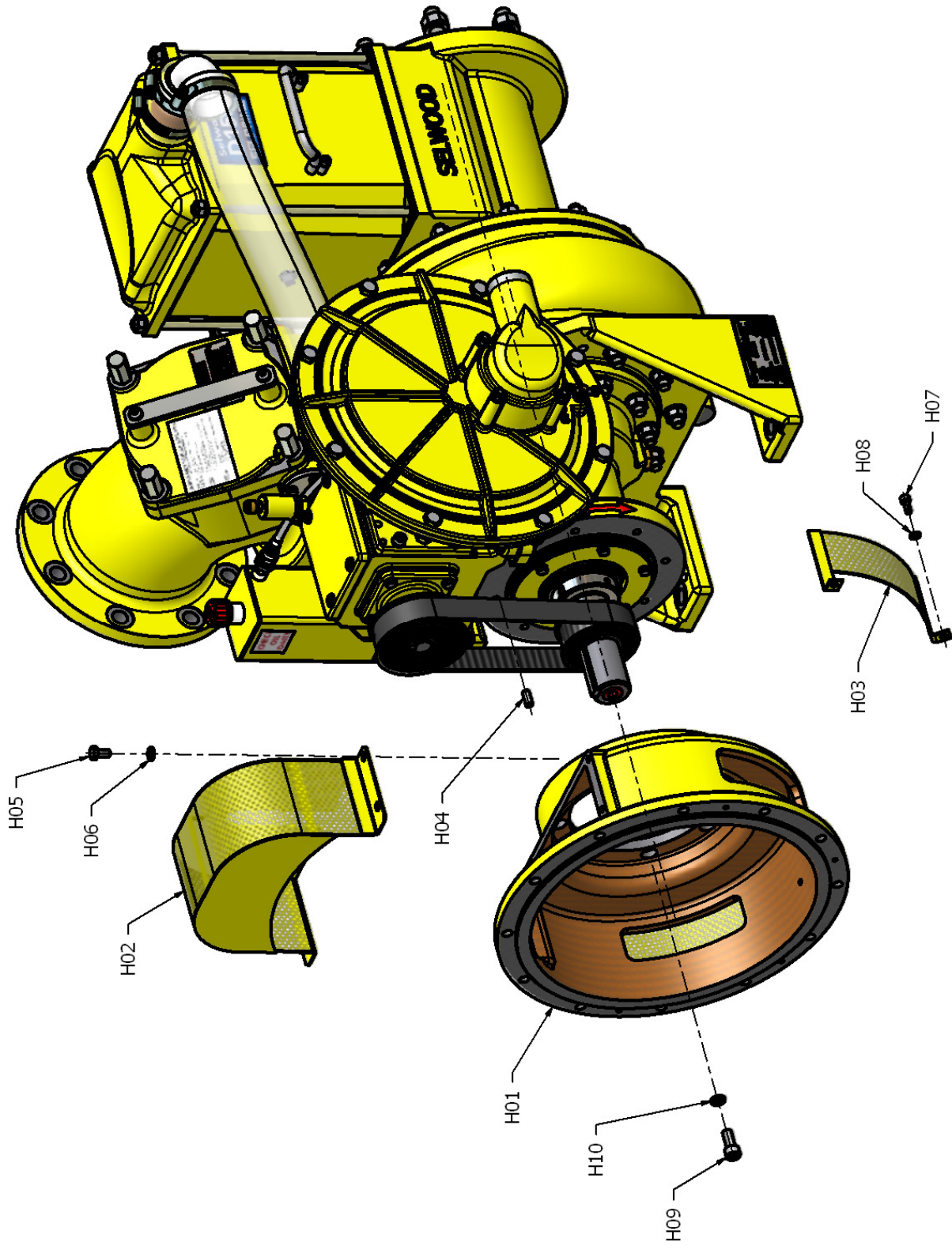

9.8 D150 Close Coupled Pump Unit 1511056000

ITEM	DESCRIPTION	PART NUMBER	QTY
H01	Bell Housing	1509297000	1
H02	Belt Cover	1509298000	1
H03	Vent Cover	1509299000	2
H04	8 x 20 Dowel Pin	9000869-01	1
H05	Hex Hd Setscrew M8 x 16 lg	9000080161	4
H06	Spring Washer M8	9030080229	4
H07	Hex Socket Cap Hd Screw M6 x 16 lg	9000641-01	4
H08	Spring Washer M6	9030060229	4
H09	Hex Socket Cap Hd Screw M10 x 25 lg	9005100250	8
H10	Spring Washer M10	9001079-01	8

When ordering spares, please state:

PUMP NUMBER - PART NUMBER - DESCRIPTION OF PART

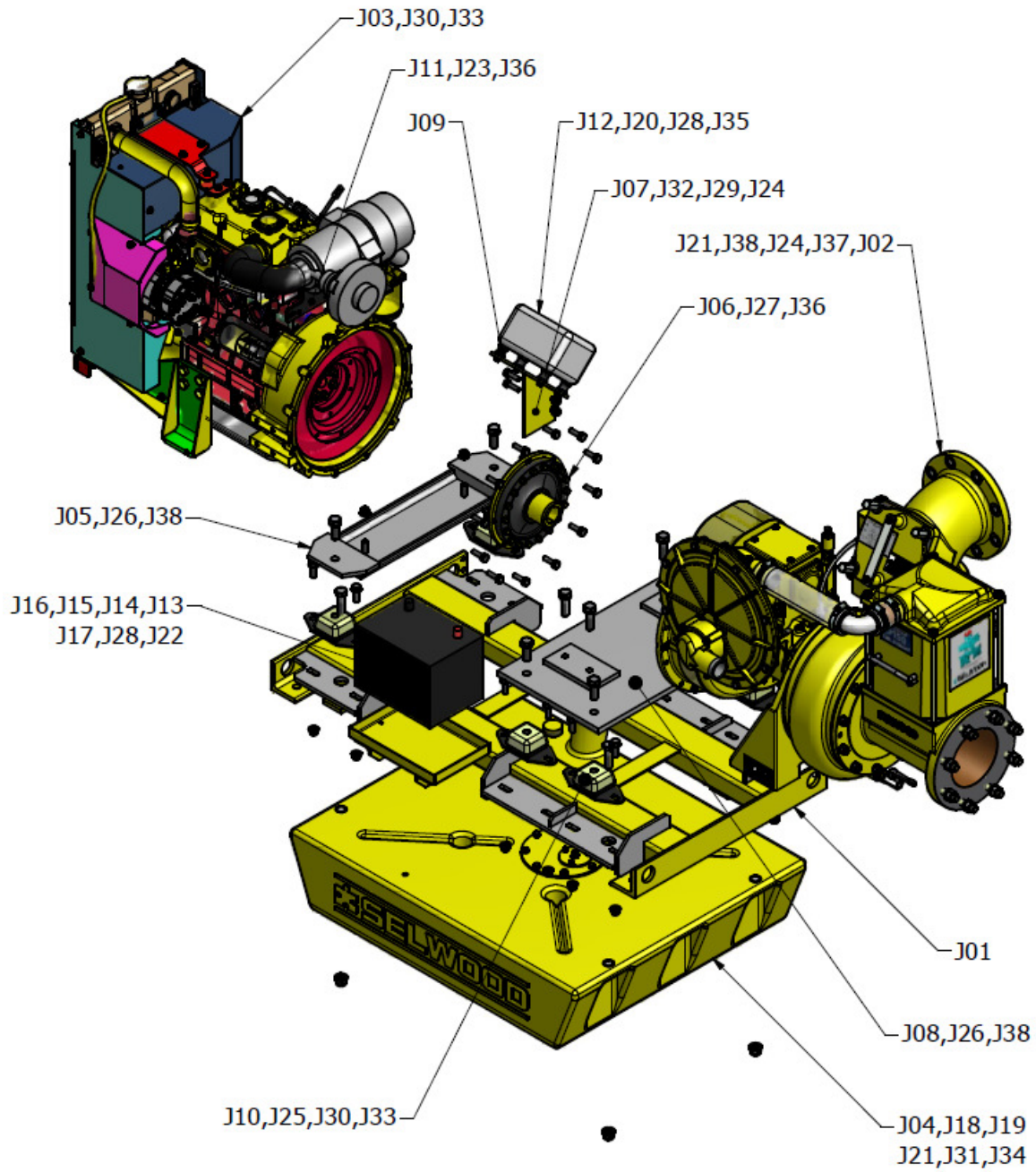

9.9 D150R CC CORE BUILD 1511039000

ITEM	DESCRIPTION	PART NUMBER	QTY
J01	Chassis Frame (D150R CC / PERKINS 403D-15)	1511040000	1
J02	D150 CC Pump unit c/w air pump, Delivery Valve, Separator & 231mm Dia Impellor	1511056000	1
J03	Perkins 403D-15 Diesel Engine	92024-0004	1
J04	Plastic Fuel Tank Assembly (105 Ltr)	1502478000	1
J05	Crossmember Assembly	1511042000	1
J06	Centamax 120 Coupling	9600M00029	1
J07	Control Panel Bracket	1511041000	1
J08	Saddle Plate	1510373000	1
J09	A/V Mount DEX 34	9680M00006	4
J10	A/V Mount (M16)	9680M00038	6
J11	Air Cleaner Mounting Bracket	1510424000	1
J12	Control Panel	92700-0361	1
J13	12V Battery, 065 Type	92800 - 0127	1
J14	Clamp Bar	7598280000	1
J15	Battery Lead +VE	2092249000	1
J16	Battery Lead -VE	1092070000	1
J17	Terminal Boot	92800 - 0008	2
J18	Fuel line – Tank to lift pump	1001195000	1
J19	Fuel line – Leak off to tank	1001196000	1
J20	Engine Side Loom	92700-0360	1
J21	Hex head bolt M16 x 55	9001160551	8
J22	Hex head setscrew M6 x 25	9000060250	2
J23	Hex head setscrew M8 x 25	9000080251	2
J24	Hex head setscrew M10 x 35	9000100351	14
J25	Hex head setscrew M12 x 35	9000120351	12
J26	Hex head setscrew M16 x 45	9000160451	6
J27	Socket head capscrew M8 x 20	9005080200	6
J28	Hex full nut M6	9025060004	6
J29	Hex nyloc nut M10	9025100344	2
J30	Hex nyloc nut M12	9025120344	14
J31	Hex nyloc nut M16	9025160344	4
J32	Plain washer M10	9030100024	2
J33	Plain washer M12	9030120024	26
J34	Plain washer M16	9030160024	4
J35	Spring washer M6	9030060229	4
J36	Spring washer M8	9000879-01	8
J37	Spring washer M10	9030100229	12
J38	Spring washer M16	9030160229	10

When ordering spares, please state:

PUMP NUMBER - PART NUMBER - DESCRIPTION OF PART

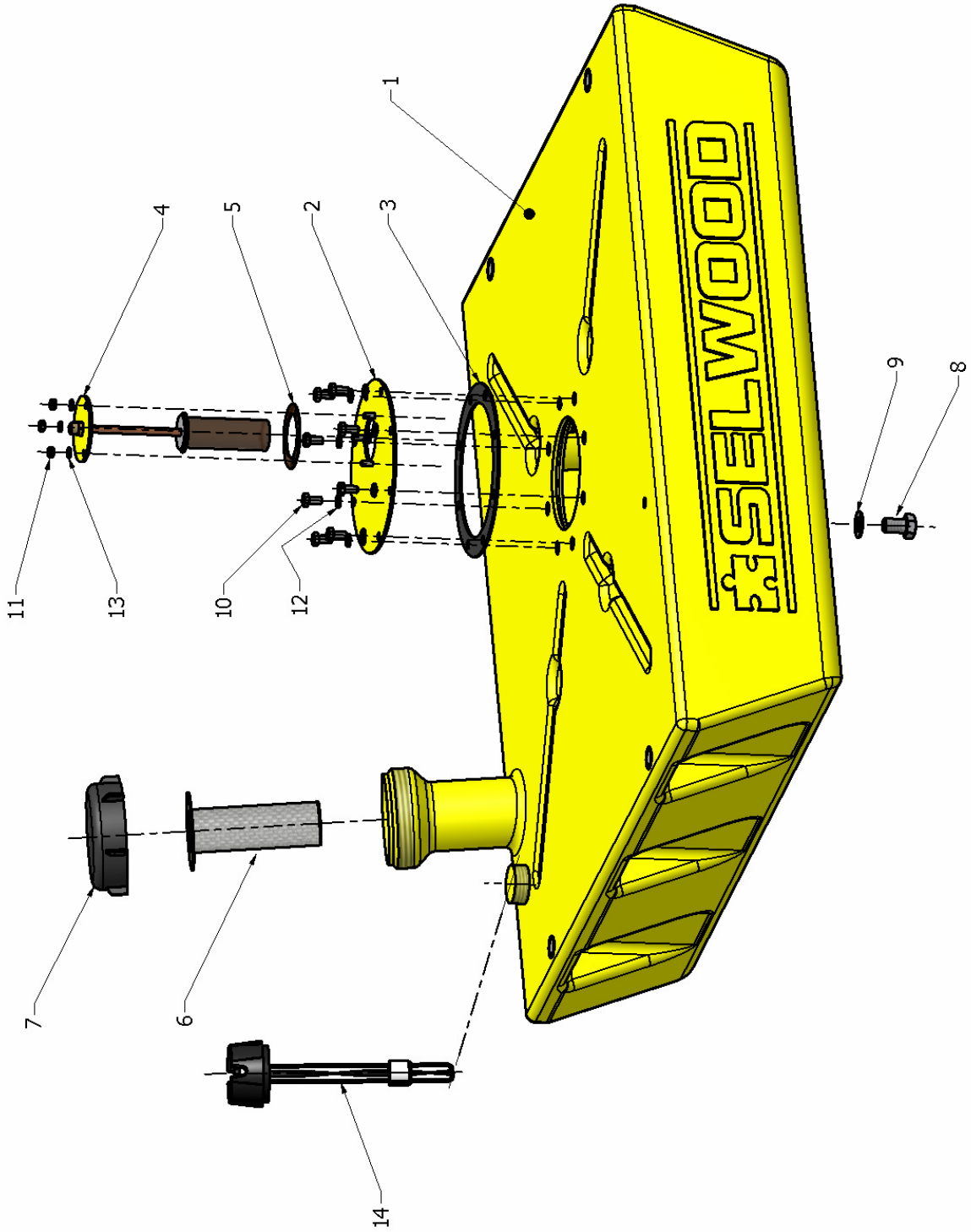

10 PLASTIC FUEL TANK ASSEMBLY 1502478000

ITEM	DESCRIPTION	PART NUMBER	QTY
K01	Plastic Fuel Tank (105 Ltr)	1502503000	1
K02	Fuel Tank Inspection Cover	1503405000	1
K03	Fuel Tank Inspection Cover Gasket	1503406000	1
K04	Fuel Tank Feed Filter Assy	0006671000	1
K05	Fuel Tank Feed Filter Gasket	0015063000	1
K06	Filler Neck Filter (Plastic Tank)	1503376000	1
K07	Plastic Filler Cap	9550M11503	1
K08	Drain Plug, M16 x 2.00 x 25mm Long	9521M01601	1
K09	Dowty Washer	9534M00301	1
K10	Hex HD Setscrew M8 x 16 LG	9000080161	8
K11	Hex Full Nut M6	9025060004	3
K12	Spring Washer M8	9030080229	8
K13	Spring Washer M6	9030060229	3
K14	Fuel Tank Contents Gauge (Optional)	9590K06402	1

When ordering spares, please state:
PUMP NUMBER - PART NUMBER - DESCRIPTION OF PART

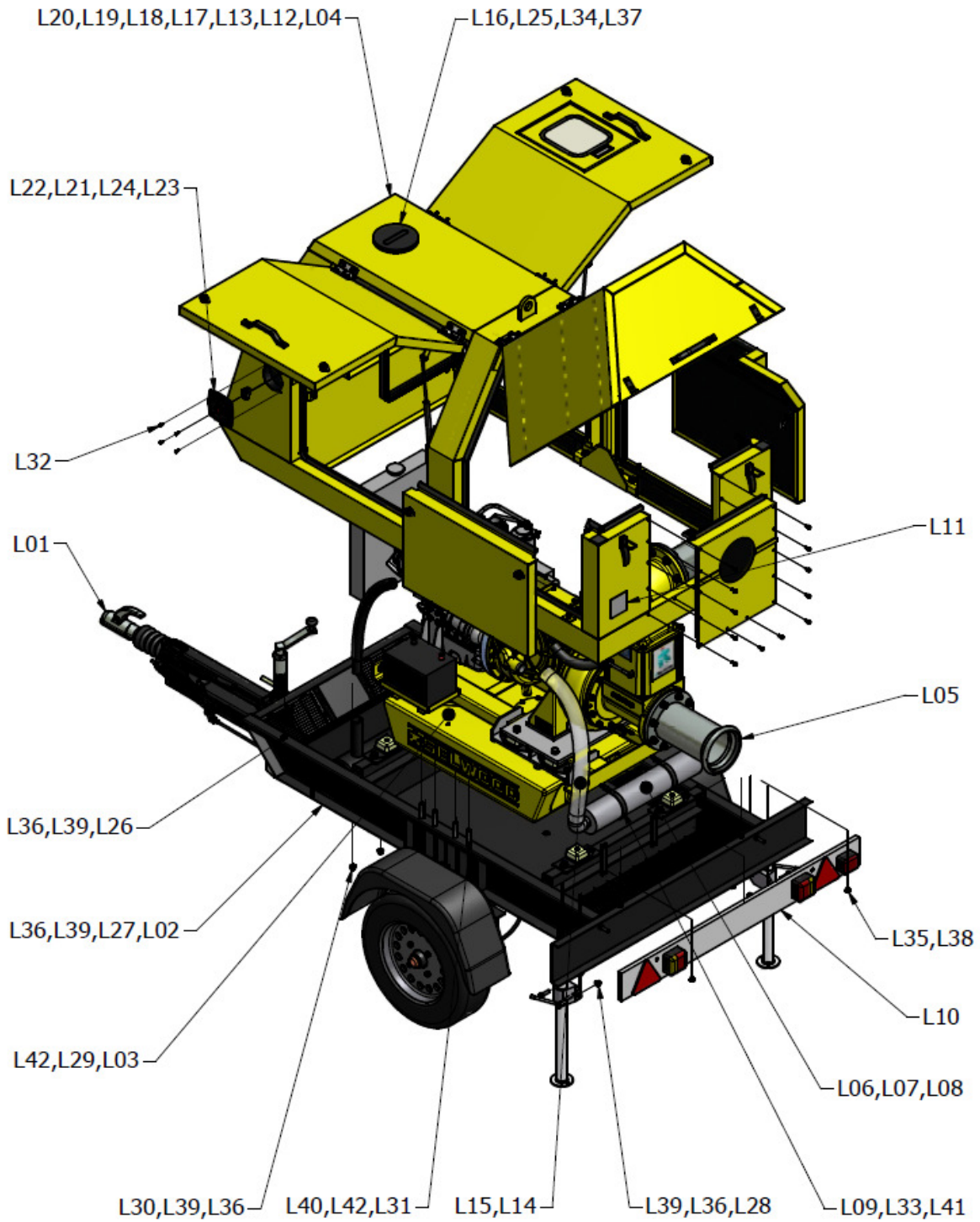

11 D150R CC / PERKINS 403D-15 RAPID RESPONSE 1511038000

ITEM	DESCRIPTION	PART NUMBER	QTY
L01	Two wheel trailer with 50mm ball hitch	9729-00022	1
L02	D150R Skid chassis and drip tray	1505228000	1
L03	D150R CC/Perkins 403D-15 Core assembly	1511039000	1
L04	D150R Close coupled Acoustic canopy	1511045000	1
L05	D150 Flange Bauer / strainer kit	1502421000	1
L06	Air pump silencer 1 1/2" BSP connections	9510P01201	1
L07	Spigot	1589144000	1
L08	90 Equal elbow 1 1/2" BSP	9517P01202	1
L09	Clamp	1503021000	2
L10	Lighting Board	9730001000	1
L11	Sound power label	1506094000	1
L12	Wiring loom – emergency stop buttons	1506070000	1
L13	Bauer Surround Gasket	1503164000	2
L14	Worm drive hose clip	9505007004	2
L15	Suction hose 50mm I/Dia	9542000000	1
L16	Chain	0003517000	A/R
L17	Cable clip self adhesive	9705003000	8
L18	CE Manufacturer plate	0015071000	1
L19	Rating plate	1594154000	1
L20	Hammer drive screw	9045002259	4
L21	Black coated dish pan	9278-00045	2
L22	Gasket	9278-00046	2
L23	Mushroom push button	92800-0054	2
L24	Contact block	92800-0055	2
L25	Hex head setscrew M6 x 25	9000060250	2
L26	Hex head setscrew M12 x 25	9000120251	4
L27	Hex head setscrew M12 x 30	9000120301	4
L28	Hex head setscrew M12 x 40	9000120401	4
L29	Hex head setscrew M16 X 30	9000160301	4
L30	Hex head bolt M12 x 60	9001120601	2
L31	Hex head bolt M16 X 80	9001160801	8
L32	Socket C/sunk screw M5 x 16	9000540-01	8
L33	Hex full nut M8	9025080004	4
L34	Hex nyloc nut M6	9025060344	2
L35	Hex nyloc nut M10	9025100344	2
L36	Hex nyloc nut M12	9025120344	14
L37	Plain Washer M6	9030060024	4
L38	Plain Washer M10	9030100024	2
L39	Plain washer M12	9030120024	14
L40	Plain washer M16	9030160024	8
L41	Spring washer M8	9030080229	4

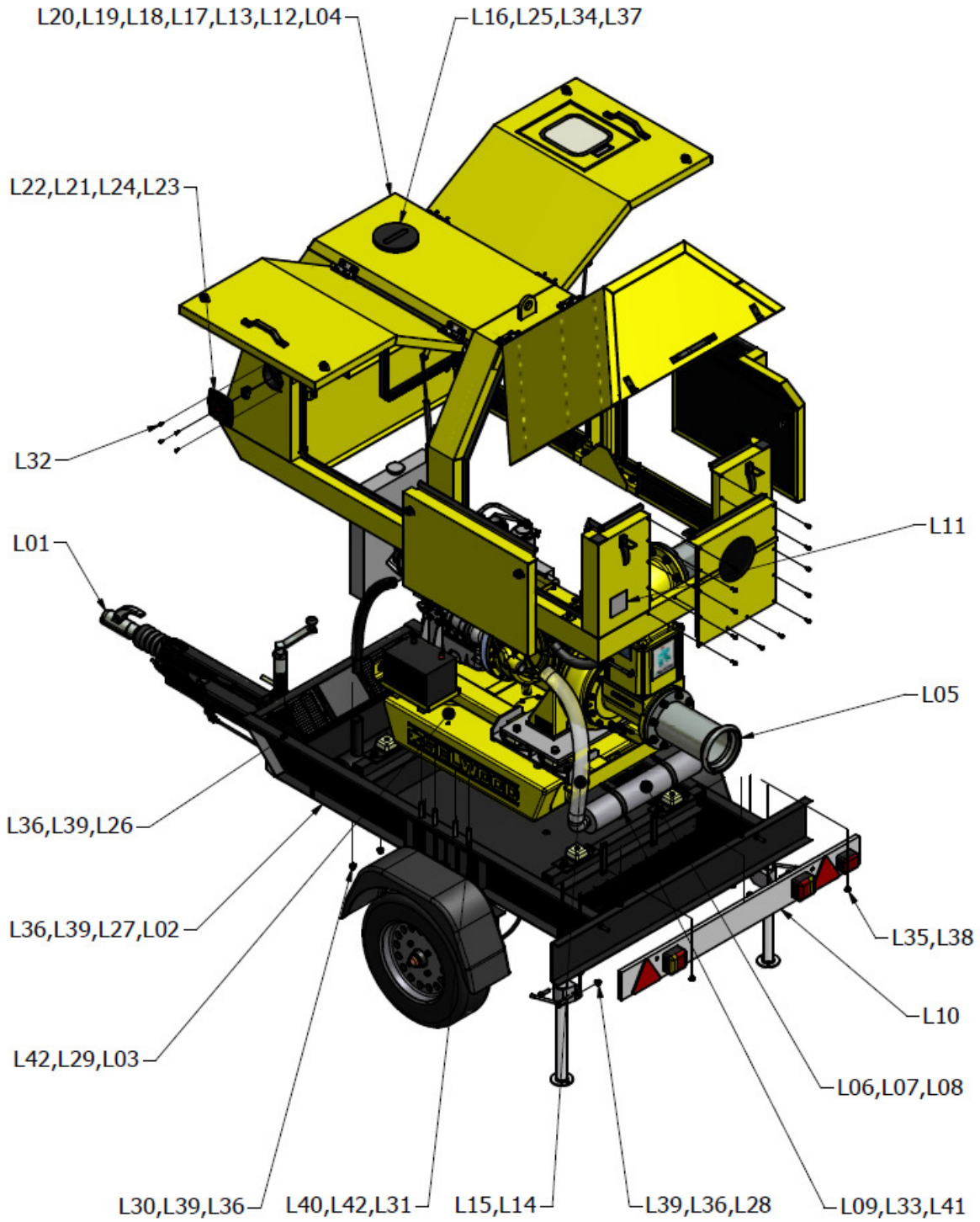

ITEM	DESCRIPTION	PART NUMBER	QTY
L42	Spring washer M16	9030160229	12
L43	A/V mount	REF ONLY	4
L44	Flexible exhaust pipe	REF ONLY	1
L45	Exhaust silencer clamp	REF ONLY	2

When ordering spares, please state:

PUMP NUMBER - PART NUMBER - DESCRIPTION OF PART

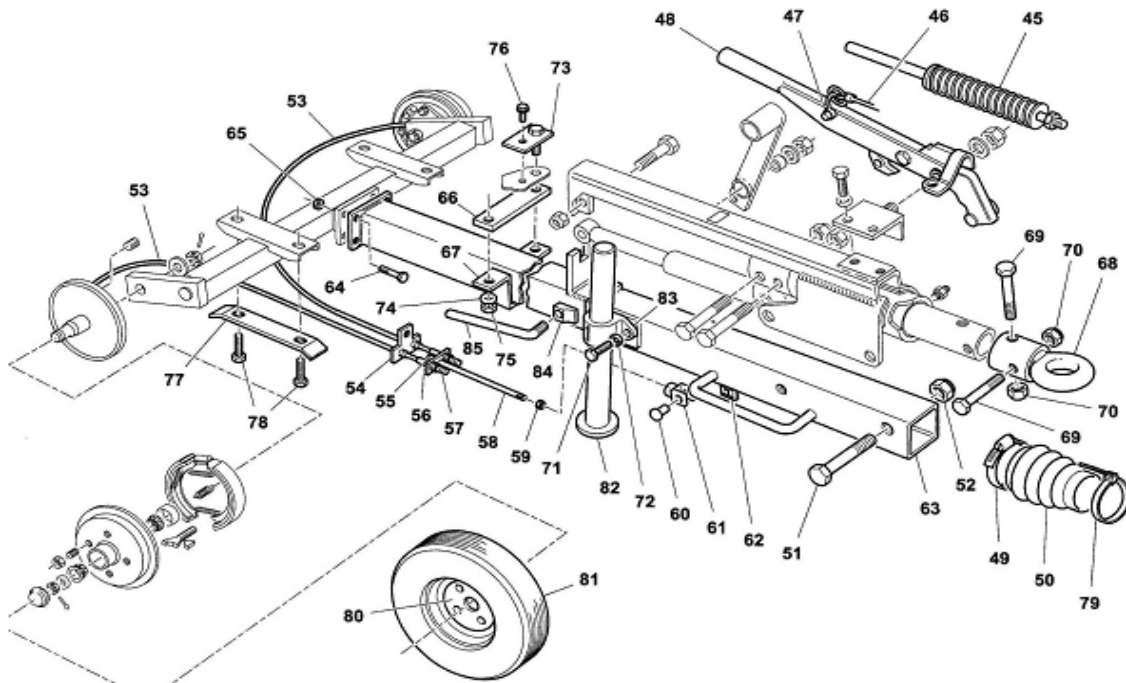
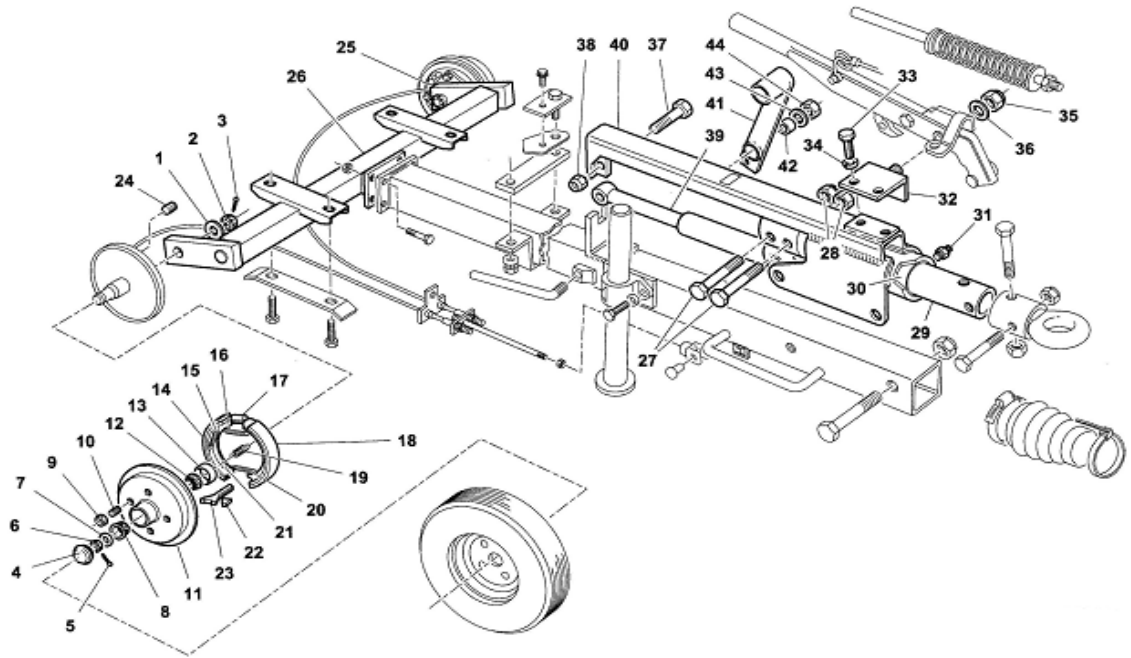

12 2 WHEEL TRAILER ASSY 9729-00022

ITEM	DESCRIPTION	PART NUMBER.	QTY
4	Hub Cap	1061 02	1
5	Split Pin	1/8" X 1.1/4"	1
6	Slotted Nut	3/4 UNF	1
7	Washer	1053 05	1
8	Bearing (outer)	L44649/44610	1
9	Wheel Nut	1027 07	4
10	Stud	1026 15	4
11	Hub	1203 03	1
12	Bearing (inner)	LM48548/48510	1
13	Seal	162262	1
14	Shoe (reversing)	35259-21.02	1
15	Spring (carrier spring)	42904	2
16	Spring (top tension spring)	42903	1
17	Expander	45309	1
18	Shoe (fixed)	35261-21.02	1
19	Spring (shoe steady spring)	42861.01	1
20	Spring (bottom tension spring)	42126	1
21	Carrier	34648	1
22	Adjuster Wedges	45200	2
23	Bolt & Nut assembly	44826	1
24	Plug	V10.1	1
25	Holder, cable	45146	1
27	Bolt M10 x 75	M10 x 75	2
28	Self Locking Nut	M10	2
29	Shaft	1118 00	1
30	Bush	1208 00	2
31	Grease Nipple	5/16" UNF	2
32	Bracket	1195 14	1
33	Setscrew	M10 x 30	2
34	Spring Washer Square Section	M10	2
35	Self Locking Nut	M16	1
36	Washer	M16	1
37	Bolt	M10x50	1
38	Self Locking Nut	M10	1
39	Damper	043311	1
40	Frame	1123 00	1
41	Lever	1127 01	1
42	Bush	CT529	1
43	Washer	M12	1
44	Self Locking Nut	M12	1
45	Spring Store	1117 00	1
46	Cable	1050 00	1
47	D Shackle (1/4" Pin)	1/4"	1
48	Lever, handbrake (complete)	1195 00	1
49	Clip, retaining (rear)	55/70	1
50	Cover	1075 04	1

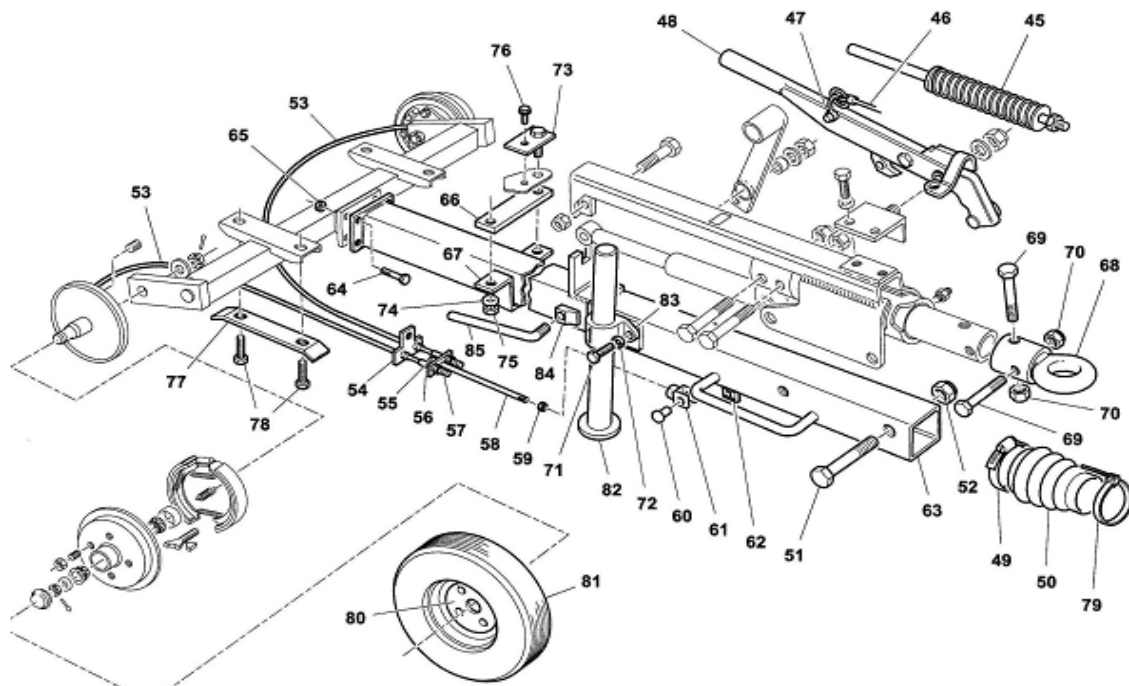
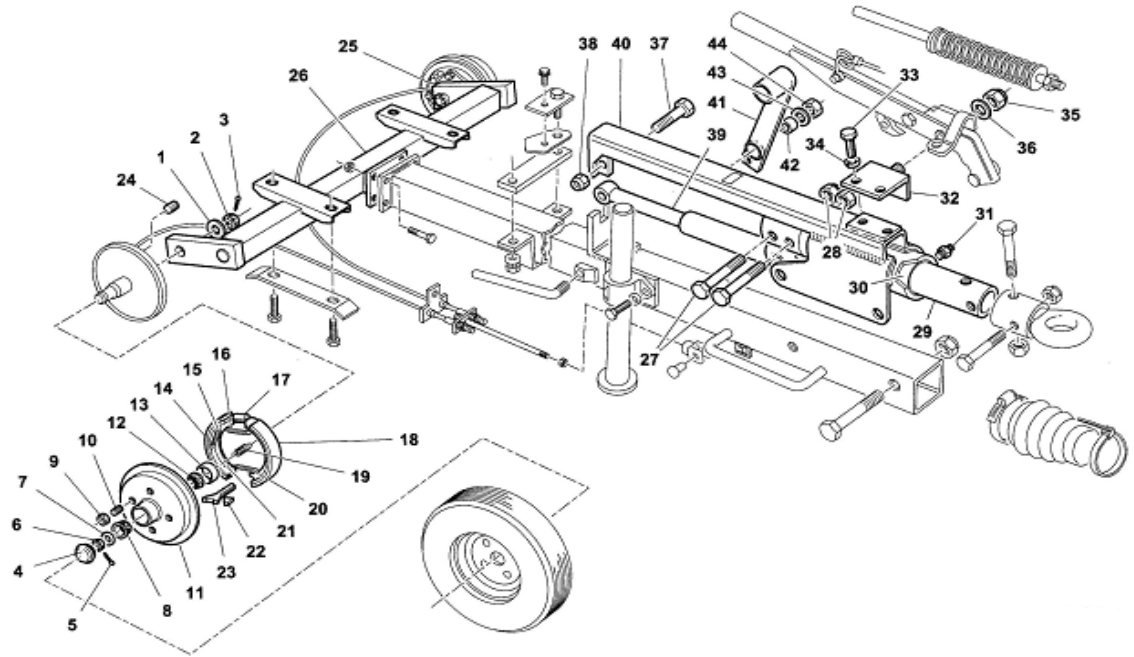

ITEM	DESCRIPTION	PART NUMBER.	QTY
51	Bolt	1/2" UNF x 4 1/2"	2
52	Self Locking Nut	1/2" UNF	2
53	Cable	1165 04	2
54	Plate (cable anchor)	1192 01	1
55	Nut	5/16" UNF	2
56	Plate (compensator)	1017 03	1
57	Self Locking Nut	M12	1
58	61" Rod	1080 17	1
59	Nut	5/16" UNF	1
60	Pin	NBI312	1
61	Fork (clevis)	GK1312	1
62	Clip, retaining	SLM8F2	1
63	Tube Towbar	1137 92	1
64	Setscrew	M10 x 35	4
65	Self Locking Nut	M10	4
66	Pad	1044 21	1
67	Clamp	1041 01	1
68	Towing Eye 2" BSAU	1102 01	1
68	Towing Hitch 50mm Ball	1205 00	1
69	Bolt	M10 x 75	2
70	Self Locking Nut	M10	2
71 – 78	Chassis to Body Fixings		
79	Tie Wrap 350mm	REL250	1
80	Wheel	REL250	1
81	Tyre	REL250	1
83 – 85	Cast Bracket Assembly	B42C3	1
	OR		
82	Jockey Wheel	J348S	1
83 – 85	Cast Bracket Assembly	B48C6	1

When ordering spares, please state:

PUMP NUMBER - PART NUMBER - DESCRIPTION OF PART

13 WIRING DIAGRAMS

13.1 Fast Tow Trailer Lighting Circuit

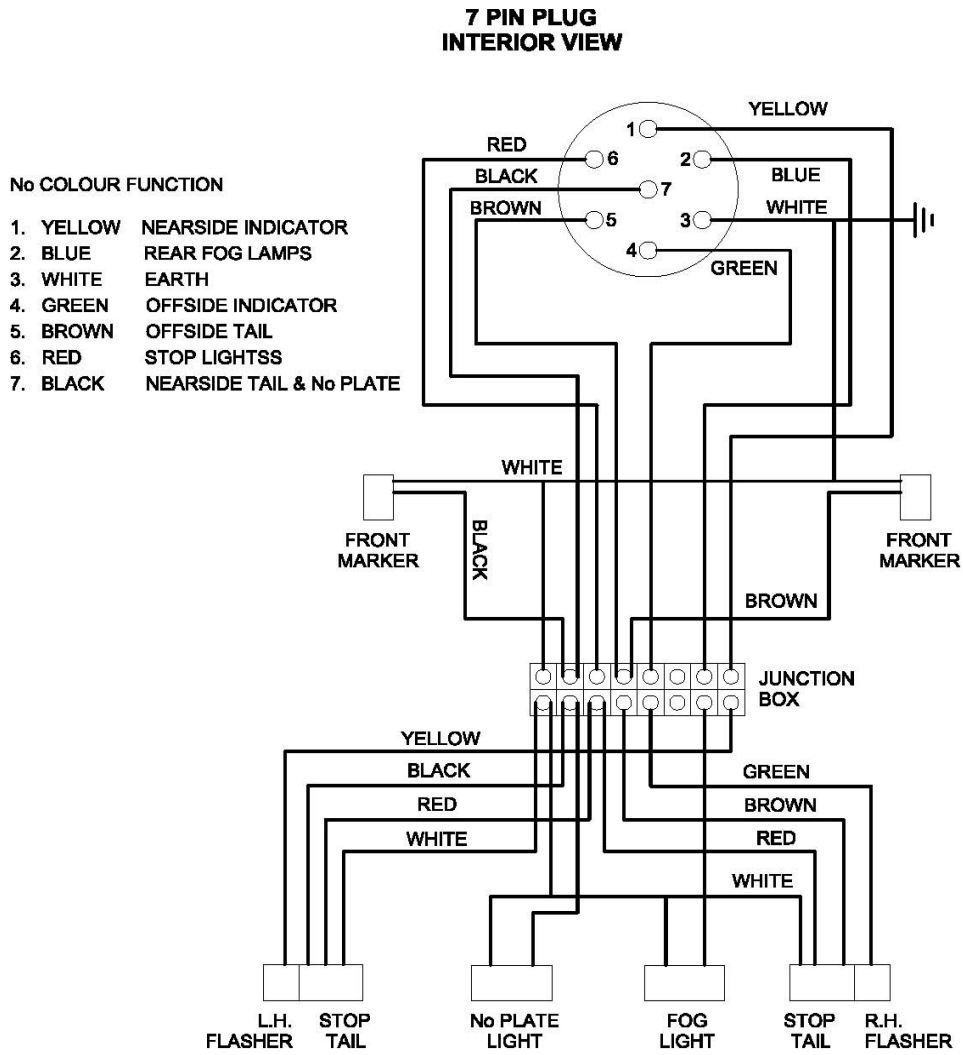

NOTE: Front marker lights are not relevant to this Build.