

Vehicle Standards Information 6

June 2021

This information sheet supersedes all previous copies of VSI 6.

Requirements for A-frame towing of vehicles

This Vehicle Standards Information sheet provides the requirements for assemblies used to undertake A-frame towing of a motor vehicle in a manner that satisfies Rule 294 of the *Road Safety Road Rules 2017*.

This information sheet applies to vehicles with a Gross Vehicle Mass (GVM) of 4.5 tonne or less. For heavy vehicle requirements please refer to the National Heavy Vehicle Regulator website at nhvr.gov.au.

Introduction

A-frame towing is the term used to refer to towing a motor vehicle, which has all its wheels on the road and is connected to the towbar of the towing vehicle by a triangular shaped frame commonly known as an A-frame. The A-frame enables the lead vehicle to control the movement of the towed vehicle.

Rule 252 of the *Road Safety (Vehicles) Interim Regulations 2020* requires that the driver of a motor vehicle not tow another motor vehicle unless it is safe to do so and either they have control of the movement of the towed vehicle or there is a suitably licensed driver in the towed vehicle

controlling its movement. An A-frame towing assembly can provide a driver with control of the movement of a towed vehicle.

Vehicle Assessment Signatory Scheme (VASS) Approval Certificate

A VASS Approval Certificate is a certificate that can be accepted as evidence that a modified vehicle has been inspected, and that all modifications have been carried out and completed in accordance with recognised standards and codes of practice, and that the vehicle in its modified form continues to comply with the Standards for Registration. An Approval Certificate can only be issued by a Signatory authorised under the Vehicle Assessment Signatory Scheme (VASS).

A list of VASS signatories is available from any VicRoads Customer Service Centre or the VicRoads website.

Requirements

Persons wishing to undertake A-frame towing may need to seek advice from a VASS Signatory to ensure that the A-frame device that they intend to use meets the technical requirements of this information sheet.

If the tare mass of the towing vehicle is less than 3.5 times the laden mass of the towed vehicle, control of the brakes on the towed vehicle is required. In such cases a VASS Approval Certificate is required to certify that the A-frame and braking system are fit for purpose.

A VASS certificate is required if the A-frame coupling is fitted to a towed vehicle manufactured after 1 July 1995. It is recommended to consult a VASS signatory prior to beginning any modifications.

Persons who tow a registered motor vehicle in accordance with this information sheet must check requirements with all states and territories being travelled to. In particular, check with New South Wales Roads and Maritime Services when towing with an A-frame between Victoria and New South Wales as the requirements are significantly different between the jurisdictions.

In some jurisdictions (but not Victoria), it may be an offence to tow an unregistered motor vehicle.

It is recommended that a copy of this information sheet, together with any reports, approvals or other documentation is carried in the vehicle at all times.

Requirements for towing a vehicle using an A-frame outside of Victoria may vary. The responsibility is on the vehicle operator to comply with the requirements regulated in each State and Territory.

Coupling design

The A-frame coupling must:

- not adversely affect the towed vehicle's compliance with frontal crash test requirements in the Australian Design Rules (ADRs).

For towed vehicles manufactured after 1 July 1995 a VASS certificate is required

- be designed and constructed with sufficient strength to hold the vehicles together in tow and must comply with the applicable requirements of ADR 62 Mechanical Connections Between Vehicles relevant to the laden mass of the towed vehicle
- permit an adequate amount of angular movement between the towing and towed vehicles to cater for road undulations and curves
- be secured to a substantial body member of the towed vehicle, such as a sub-frame or chassis member. Connection to the towed vehicle's bumper, suspension or steering components is not permitted, unless approved by the manufacturer of the towed vehicle
- maintain a space between elements of the combination not exceeding 2 metres.

Coupling markings

A-frame couplings must be permanently and legibly marked with the following information in accordance with ADR 62:

- the manufacturer's name or trademark. The "manufacturer" may include the owner in the case of a privately constructed device
- the words "use with model (identified model)"
- for towed vehicles under 3.5 tonnes, the maximum allowable laden mass of the towed vehicle (in kg or tonne) at which the A-frame is rated
- for towed vehicles with a laden mass over 3.5 tonnes, the rated 'D-value' or the rated 'D-value' and 'V-value' in kN. 'D-value' and 'V-value' are defined in the ADR

Safety chains/cables

The A-frame coupling must be equipped with safety chains or cables that comply with the requirements of Vehicle Standards Bulletin 1 as published on the Commonwealth Department of Infrastructure, Transport, Regional Development and

Communications (DITRDC) website. If safety cables are to be used then advice must be sought from a VASS signatory to ensure the cables are of suitable construction and strength.

Towing capacity of towing vehicle

- The towing limits specified by the vehicle manufacturer must not be exceeded (most manufacturers specify towing limits for their vehicles in the vehicle handbook).
- The loaded mass of the towed vehicle must not exceed the towing capacity of any component in the combination, including the A-frame, towbar, coupling and towball.

Braking requirements

- The requirement for a 1:3.5 towed mass ratio is designed to give a combination adequate braking without the need for the brakes of the towed vehicle to be operated by the driver seated in the towing vehicle.
- The vehicle combination must meet the minimum braking performance requirements of **Table 1 – Minimum braking requirements** below with one sustained application of the service brakes, under normal operation and application conditions, on a dry smooth level surface free from loose material.
- The parking brake of the towing vehicle must be able to hold the vehicle combination stationary on a 12% gradient.

Lighting requirements

The following lights must be fitted to the rear of the towed vehicle and be operational whilst under tow:

- two amber turn signal lamps
- two red stop lamps
- one white reverse lamp
- one registration plate lamp at the rear of the towed vehicle to illuminate the registration plate
- two red tail lamps.

These lamps may be the towed vehicle's own lights or as an alternative

be arranged on a portable light bar providing it is properly secured to the rear of the towed vehicle.

Steering requirements

The safety of the vehicle combination's steering is vital. The A-frame towing system shall provide safe and adequate steering control for the towed vehicle, and the overall combination. The stability and tracking of the vehicle combination and the steer-ability of the towed vehicle must be satisfactorily addressed:

- the vehicle combination must be capable of turning within a 25m diameter circle, measured at the outer wheel track of the combination
- when travelling in a straight line on a level, smooth surface the towed vehicle must track (follow) in the path of the towing vehicle without deviating off-line by over 100mm.

Vehicle and towing components manufacturer's requirements

The vehicle manufacturer's recommendations must be complied with whilst carrying out A-frame towing. Vehicle owners are advised to check with their manufacturer/dealer to determine whether their towed vehicle is suitable for A-frame towing.

Advice given in the "Owner's Manual" for the towing of the vehicle should always be followed.

Loads in towed vehicle

Carrying a load in the towed vehicle is not forbidden. However, when carrying such a load it is important to consider the following points:

- the loaded mass of the towed vehicle must not exceed the capacity of any component in the combination
- where the towed vehicle is unbraked the tare mass of the towing vehicle must remain greater than 3.5 times the mass of the towed vehicle when the vehicle is loaded
- any load carried in the towed vehicle should be placed as low and as centrally as possible. Large, heavy items carried high up in the

towed vehicle will adversely affect the handling of the combination and may render towing unsafe.

Other requirements

- The overall length of the vehicle combination must not exceed 19.0 metres. See **Figure 1 – A Frame maximum overall length**.
- The A-frame, and any attachment which would constitute a dangerous projection, must be removed from the towed vehicle before it is driven on public roads.
- If the towed vehicle is unregistered, the registration plate of the towing vehicle needs to be visible, but not attached where the registration plate would otherwise be on the towed vehicle.
- If the length of the vehicle combination is over 7.5 metres or longer, it is recommended that you have the sign 'Do Not Overtake Turning Vehicle' displayed at the rear of the combination. See **Figure 2 – Do not overtake turning vehicle**.

For further information

Further information is available on the VicRoads website: vicroads.vic.gov.au or by calling VicRoads on **13 11 71** (TTY **13 36 77**, Speak and Listen **1300 555 727**).

Table 1: Minimum braking requirements

	Stopping distance from 35km/h	Minimum average deceleration from any legal speed	Minimum peak deceleration from any legal speed
Vehicle combination gross mass under 2.5 tonnes	12.5 m	3.8 m/s ² (0.39 g)	5.8 m/s ² (0.59 g)
Vehicle combination gross mass 2.5 tonnes or over	16.5 m	2.8 m/s ² (0.29 g)	4.4 m/s ² (0.45 g)

Figure 1: A frame maximum overall length

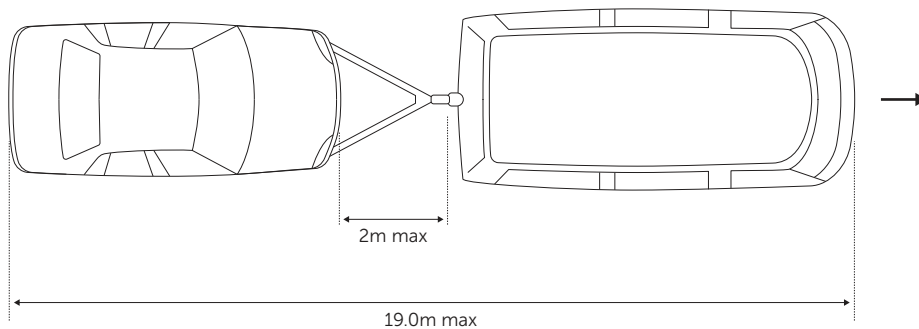

Figure 2: Do not overtake turning vehicle

