

# Inspections



---

## Do Not Operate Unless:

- You learn and practice the principles of safe machine operation contained in this operator's manual.
  - 1 Avoid hazardous situations.
  - 2 Always perform a pre-operation inspection.**
- Know and understand the pre-operation inspection before going on to the next section.**
- 3 Always perform function tests prior to use.
- 4 Inspect the workplace.
- 5 Only use the machine as it was intended.

## Pre-operation Inspection Fundamentals

It is the responsibility of the operator to perform a pre-operation inspection and routine maintenance.

The pre-operation inspection is a visual inspection performed by the operator prior to each work shift. The inspection is designed to discover if anything is apparently wrong with a machine before the operator performs the function tests.

The pre-operation inspection also serves to determine if routine maintenance procedures are required. Only routine maintenance items specified in this manual may be performed by the operator.

Refer to the list on the next page and check each of the items.

If damage or any unauthorized variation from factory delivered condition is discovered, the machine must be tagged and removed from service.

Repairs to the machine may only be made by a qualified service technician, according to the manufacturer's specifications. After repairs are completed, the operator must perform a pre-operation inspection again before going on to the function tests.

Scheduled maintenance inspections shall be performed by qualified service technicians, according to the manufacturer's specifications and the requirements listed in the responsibilities manual.

# Inspections

## Pre-operation Inspection

- Be sure that the operator's, safety and responsibilities manuals are complete, legible and in the storage container located in the platform.
- Be sure that all decals are legible and in place. See Inspections section.
- Check for hydraulic oil leaks and proper oil level. Add oil if needed. See Maintenance section.
- Check for battery fluid leaks and proper fluid level. Add distilled water if needed. See Maintenance section.
- Check for engine oil leaks and proper oil level. Add oil if needed. See Maintenance section.
- Check for engine coolant leaks and proper level of coolant. Add coolant if needed. See Maintenance section.

Check the following components or areas for damage, improperly installed or missing parts and unauthorized modifications:

- Electrical components, wiring and electrical cables
- Hydraulic hoses, fittings, cylinders and manifolds
- Drive motors
- Wear pads
- Tires and wheels
- Limit switches, alarms and horn
- Alarms and beacons (if equipped)
- Nuts, bolts and other fasteners
- Brake release components

- Safety arm
- Platform extension
- Scissor pins and retaining fasteners
- Platform control joystick
- Outrigger housing and footpads (if equipped)
- Fuel and hydraulic tanks
- Engine and related components
- Platform entry gate
- Generator (if equipped)

Check entire machine for:

- Cracks in welds or structural components
- Dents or damage to machine
- Excessive rust, corrosion or oxidation
- Be sure that all structural and other critical components are present and all associated fasteners and pins are in place and properly tightened.
- Be sure side rails are installed and bolts are fastened.

Note: If the platform must be raised to inspect the machine, make sure the safety arm is in place. See Operating Instructions section.

# Inspections



---

## Do Not Operate Unless:

- You learn and practice the principles of safe machine operation contained in this operator's manual.
  - 1 Avoid hazardous situations.
  - 2 Always perform a pre-operation inspection.
  - 3 Always perform function tests prior to use.**

### Know and understand the function tests before going on to the next section.

- 4 Inspect the workplace.
- 5 Only use the machine as it was intended.

## Function Test Fundamentals

The function tests are designed to discover any malfunctions before the machine is put into service. The operator must follow the step-by-step instructions to test all machine functions.

A malfunctioning machine must never be used. If malfunctions are discovered, the machine must be tagged and removed from service. Repairs to the machine may only be made by a qualified service technician, according to the manufacturer's specifications.

After repairs are completed, the operator must perform a pre-operation inspection and function tests again before putting the machine into service.

# Inspections

## At the Ground Controls

- 1 Select a test area that is firm, level and free of obstruction.
- 2 Pull out the platform and ground red Emergency Stop button to the on position.
- 3 Turn the key switch to ground control.
- ⊙ Result: The LCD screen will come on and display SYSTEM READY.

Note: In cold climates, the LCD readout screen will need to warm up before the display appears.

- 4 Start the engine. See Operating Instructions section.

## Test Emergency Stop

- 5 Push in the red Emergency Stop button to the off position.
- ⊙ Result: The engine should shut off and no functions should operate.
- 6 Pull out the red Emergency Stop button to the on position and restart the engine.

## Test the Up/Down Functions

The audible warnings on this machine and the standard horn all come from the same central alarm. The horn is a constant tone. The descent alarm sounds at 60 beeps per minute. The alarm that goes off when the machine is not level sounds at 180 beeps per minute.

- 7 Do not press the lift function enable button. Press and hold the platform up button.



- ⊙ Result: The platform should not raise.
- 8 Press and hold the lift function enable button. Press and hold the platform up button.
- ⊙ Result: The platform should raise.
- 9 Press and hold the lift function enable button. Press and hold the platform down button.
- ⊙ Result: The platform should lower. The descent alarm should sound while the platform is lowering.

# Inspections

## Test the Tilt Sensor Operation

Note: Perform this test from the ground with the platform controller. Do not stand in the platform.

- 10 Turn the key switch to platform control.
- 11 Raise the platform 7 ft / 2.13 m.
- 12 Open both ground controls side covers and locate the tilt sensor beside the ground control panel.
- 13 Press down one side of the tilt sensor and place the tilt sensor test tool under one of the posts.
- 14 Test all ground and platform control functions.
  - ⊙ Result: The alarm at the platform controls and ground controls should sound.
  - ⊙ Result: The drive function should not work in either direction. The lift function should not work.
  - ⊙ Result: The red error indicator light on the platform will be on.
- 15 Remove the tilt sensor test tool.
- 16 Lower the platform.

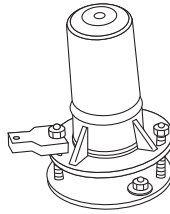

## At the Platform Controls

### Test Emergency Stop

- 17 Push in the platform red Emergency Stop button to the off position.
  - ⊙ Result: The engine should shut off and no functions should operate.
- 18 Pull out the red Emergency Stop button to the on position and restart the engine.
  - ⊙ Result: The indicator light should be green.



### Test the Horn

- 19 Press the horn button.
  - ⊙ Result: The horn should sound.

# Inspections

## Test Up/Down Functions and Function Enable

- 20 Start the engine.
- 21 Activate the up/down rocker switch in the direction indicated by the blue arrow.
  - ⦿ Result: The platform should not raise.
- 22 Press and hold the lift function enable button.
  - ⦿ Result: The platform should raise.
- 23 Activate the up/down rocker switch in the direction indicated by the blue arrow.
  - ⦿ Result: The platform should raise.
- 24 Press and hold the lift function enable button.
- 25 Activate the up/down rocker switch in the direction indicated by the yellow arrow.
  - ⦿ Result: The platform should lower. The descent alarm should sound while the platform is lowering.



## Test the Steering

Note: When performing the steer and drive function tests, stand in the platform facing the steer end of the machine.

- 26 Press and hold the function enable switch on the control handle.
- 27 Press the thumb rocker switch on top of the control handle in the direction indicated by the blue triangle on the control panel.
  - ⦿ Result: The steer wheels should turn in the direction indicated by the blue triangle.
- 28 Press the thumb rocker switch in the direction indicated by the yellow triangle on the control panel.
  - ⦿ Result: The steer wheels should turn in the direction indicated by the yellow triangle.

# Inspections

## Test Drive and Braking

- 29 Press and hold the function enable switch on the control handle.
- 30 Slowly move the drive control handle in the direction indicated by the blue arrow on the control panel until the machine begins to move, then return the handle to the center position.
  - ⊙ Result: The machine should move in the direction that the blue arrow points on the control panel, then come to an abrupt stop.
- 31 Press and hold the function enable switch on the control handle.
- 32 Slowly move the control handle in the direction indicated by the yellow arrow on the control panel until the machine begins to move, then return the handle to the center position.
  - ⊙ Result: The machine should move in the direction that the yellow arrow points on the control panel, then come to an abrupt stop.

Note: The brakes must be able to hold the machine on any slope it is able to climb.

## Test Limited Drive Speed

- 33 Press and hold the lift function enable button. Raise the platform approximately 7.5 ft / 2.28 m from the ground.
- 34 Press and hold the function enable switch on the control handle.
- 35 Slowly move the control handle to full drive position.
  - ⊙ Result: The maximum achievable drive speed with the platform raised should not exceed 0.44 ft / 13 cm per second.

If the drive speed with the platform raised exceeds 0.44 ft / 13 cm per second, immediately tag and remove the machine from service.

## Test Emergency Lowering

- 36 Push and hold the lift function enable button and raise the platform approximately 2 ft / 60 cm.
- 37 Push in the red Emergency Stop button to shut off the engine.
- 38 Pull out the red Emergency Stop button to the on position.
- 39 Press and hold the lift function enable button. Activate the up/down rocker switch in the direction indicated by the yellow arrow.
  - ⊙ Result: The platform should lower.

Note: The Emergency Stop button can be pushed when the test is performed.

# Inspections

## Test the Outrigger System (if equipped)

- 40 Push and hold the auto level button. 
- 41 Activate the up/down rocker switch in the down direction.
- ⊙ Result: The outriggers should extend and level the machine. A beep will sound when the machine is level. The indicator lights on the outrigger LED will be green.
- 42 Push and hold the auto level button.
- 43 Activate the up/down rocker switch in the up direction.
- ⊙ Result: The outriggers should retract and return to the stowed position. The indicator lights on the outrigger LED will be red.

## Test the Oscillate System

Note: Perform this test from the ground with the platform controller. Do not stand in the platform.

- 44 Start the engine from the platform controls.
- 45 Select the engine idle button to indicate high idle. Light on indicates high idle. 

## Test the Oscillate System (stowed position)

- 46 Drive the left steer tire up onto a 4 in / 10 cm high ramp.
- ⊙ Result: All four tires should maintain firm contact with the ground.
- 47 Drive the right steer tire up onto a 4 in / 10 cm high ramp.
- ⊙ Result: All four tires should maintain firm contact with the ground.

Note: Verify that there are no fault codes shown on ground control display.

## Test the Oscillate System (elevated position)

- 48 Push and hold the lift function enable button and raise the platform approximately 7 ft / 213 cm to 9 ft / 274 cm.
- 49 Drive the left steer tire into a 4 in / 10 cm deep hole.
- ⊙ Result: All four tires should maintain firm contact with the ground.
- 50 Drive the right steer tire into a 4 in / 10 cm deep hole.
- ⊙ Result: All four tires should maintain firm contact with the ground.

Note: Verify that there are no fault codes shown on ground control display.



# Inspections



## Do Not Operate Unless:

- You learn and practice the principles of safe machine operation contained in this operator's manual.
  - 1 Avoid hazardous situations.
  - 2 Always perform a pre-operation inspection.
  - 3 Always perform function tests prior to use.
  - 4 Inspect the workplace.**

**Know and understand the workplace inspection before going on to the next section.**

- 5 Only use the machine as it was intended.

## Workplace Inspection Fundamentals

The workplace inspection helps the operator determine if the workplace is suitable for safe machine operation. It should be performed by the operator prior to moving the machine to the workplace.

It is the operator's responsibility to read and remember the workplace hazards, then watch for and avoid them while moving, setting up and operating the machine.

## Workplace Inspection Checklist

Be aware of and avoid the following hazardous situations:

- drop-offs or holes
- bumps, floor obstructions or debris
- sloped surfaces
- unstable or slippery surfaces
- overhead obstructions and high voltage conductors
- hazardous locations
- inadequate surface support to withstand all load forces imposed by the machine
- wind and weather conditions
- the presence of unauthorized personnel
- other possible unsafe conditions

## Inspections

### Decals Inspection with Words

Determine whether the decals on your machine have words or symbols. Use the appropriate inspection to verify that all decals are legible and in place.

Below is a numerical list with quantities and descriptions.

Part No.	Decal Description	Qty
28158	Label – Unleaded	1
28159	Label – Diesel	1
28160	Label – Liquid Petroleum Gas (1 additional with extra LPG tank option)	1
28174	Label – Power to Platform, 230V	2
28175	Warning – Compartment Access	1
28176	Label – Missing Manuals	1
28235	Label – Power to Platform, 115V	2
28236	Warning – Improper Operation	1
28373	Label – Forklift Pocket	4
31060	Danger – Tip-over Hazard, Limit Switch	1
31788	Danger – Explosion/Burn Hazard	1
38149	Label – Patents	1
40434	Label – Lanyard Anchorage Point	6
43618	Label – Directional Arrows	1
44255	Danger – Crushing Hazard	4
44736	Danger – Tip-over Hazard, Tilt Alarm	1
44981	Label – Air Line to Platform	2
52475	Label – Transport Tie-down	4
52494	Caution – Crushing Hazard, Rails	1
52865	Warning – Annual Inspection Record	1
52967	Cosmetic – 4 x 4	2
72086	Label – Lifting Point	4
72186	Warning – Crushing Hazard, Outriggers	4
82366	Label – Chevron Rando	1
82418	Ground Control Panel	1
82557	Label – Platform Controls Location	1
82558	Warning – Skin Injection Hazard	2
82561	Danger – Crushing Hazard	2
82793	Instructions – Operating Instructions, Ground	1
97602	Warning – Explosion Hazard	1
97719	Label – Safety Arm	1

Part No.	Decal Description	Qty
114202	Label – Transport Diagram	2
114258	Danger – Explosion Hazard	1
114385	Danger – Electrocutation Hazard	2
114386	Danger – General Safety Rules	2
131587	Instructions – Kubota Diesel Engine Specs	1
133278	Label – Low Sulfur Fuel (diesel models)	1
139249	Instructions – Perkins Engine Specs	1
228327	Cosmetic – Genie GS-2669RT	2
228328	Cosmetic – Genie GS-3369RT	2
228329	Cosmetic – Genie GS-4069RT	2
228407	Ground Control Panel	1
229427	Label – Outrigger Load	4
229827	Warning – Hot Surface	3
229835	Instructions – Tire Specifications, Front	2
229871	Instructions – Kubota Gas Engine Specs	1
229915	Danger – Outrigger Safety and Instructions	1
229916	Instructions – Operating Instructions, Platform	1
230804	Instructions – Tire Specifications, Rear	2
230808	Platform Control Panel	1
826638	Instructions – Perkins 403F-11 Engine Specifications	1
1272843	Instructions – Engine Specifications (GM .998L)	1

Decal inspection continued on following page.

# Inspections

## Additional decals for models with outriggers

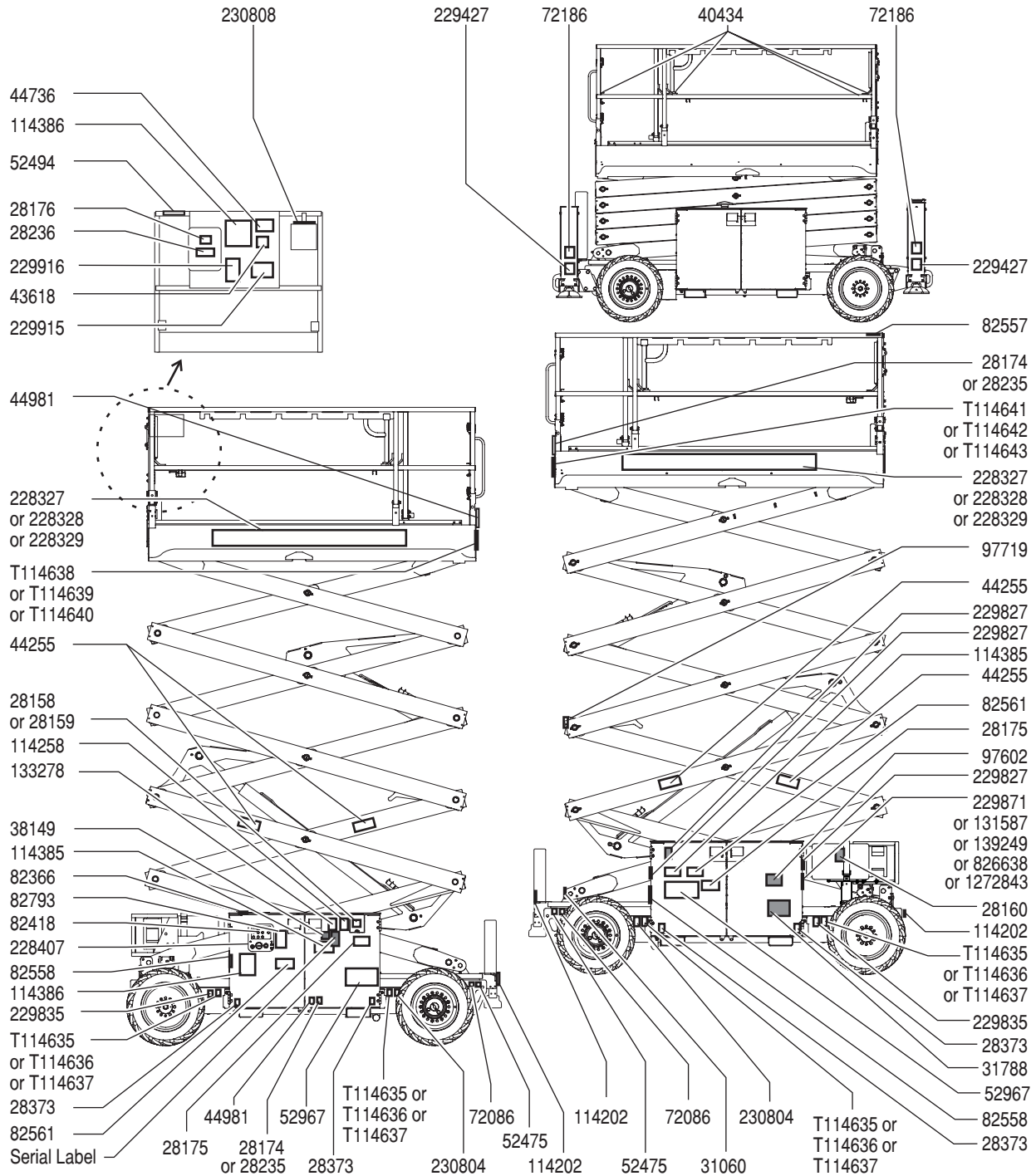

■ Shading indicates decal is hidden from view, i.e. under covers



# Inspections

## Decals Inspection with Words

Determine whether the decals on your machine have words or symbols. Use the appropriate inspection to verify that all decals are legible and in place.

Below is a numerical list with quantities and descriptions.

Decal inspection continued from previous page.

<b>Part No.</b>	<b>Decal Description</b>	<b>Qty</b>
T114635	Label – Wheel Load, GS-2669RT	4
T114636	Label – Wheel Load, GS-3369RT	4
T114637	Label – Wheel Load, GS-4069RT	4
T114638	Instructions – Max Capacity, 1500 lbs / 680 kg, GS-2669	1
T114639	Instructions – Max Capacity, 1000 lbs / 454 kg, GS-3369	1
T114640	Instructions – Max Capacity, 800 lbs / 363 kg, GS-4069	1
T114641	Instructions – Max Side Force 225 lbs / 1000 N, GS-2669RT, ANSI & CSA	1
T114642	Instructions – Max Side Force 200 lbs / 890 N, GS-3369RT, ANSI & CSA	1
T114643	Instructions – Max Side Force 150 lbs / 667 N, GS-4069RT, ANSI & CSA	1

# Inspections

## Additional decals for models with outriggers

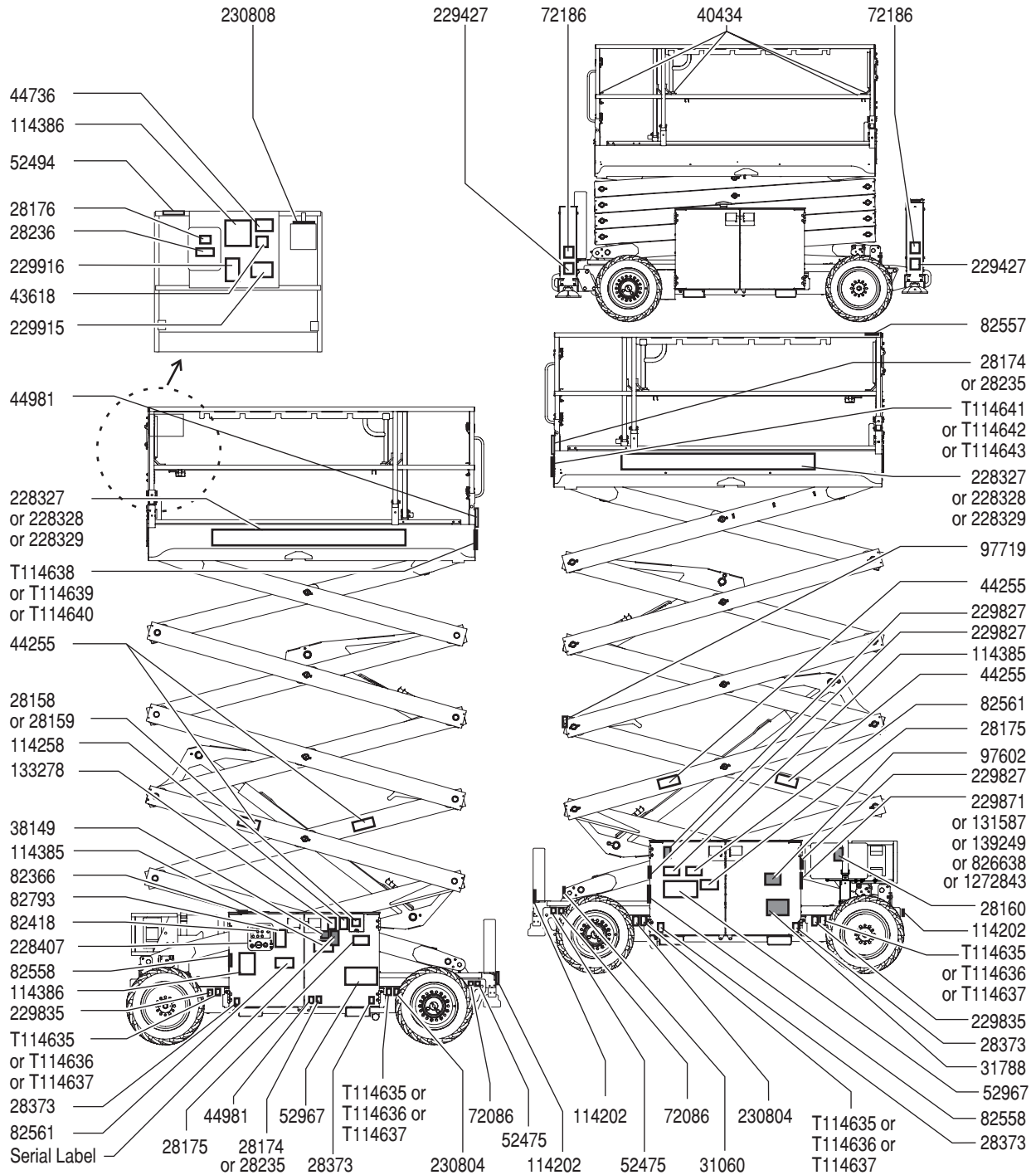

■ Shading indicates decal is hidden from view, i.e. under covers



## Inspections

### Decals Inspection with Symbols

Use the pictures on the next page to verify that all decals are legible and in place.

Below is a numerical list with quantities and descriptions.

Part No.	Decal Description	Qty
28158	Label – Unleaded	1
28159	Label – Diesel	1
28160	Label – Liquid Petroleum Gas	1
28174	Label – Power to Platform, 230V	2
28235	Label – Power to Platform, 115V	2
40434	Label – Lanyard Anchorage Point	4
43618	Label – Directional Arrows	1
44981	Label – Air Line to Platform	2
52475	Label – Transport Tie-down	4
52967	Cosmetic – 4 x 4	2
72086	Label – Lifting Point	4
82418	Ground Control Panel	1
82473	Label – Compartment Access	2
82474	Label – Use Safety Chock	2
82475	Label – Crushing Hazard, Outriggers	4
82476	Label – Electrocution Hazard	2
82481	Label – Battery/Charger Safety	1
82487	Label – Read the Manual	2
82560	Label – Skin Injection Hazard	2
82562	Label – Crushing Hazard	4
82666	Label – Forklift Pocket	4
97719	Label – Safety Arm	1
114202	Label – Transport Diagram	2
114251	Label – Explosion Hazard	1
114371	Label – Outrigger Safety	1
114337	Label – Tip-over Hazard, Limit Switch	1
114338	Label – Tip-over Hazard, Tilt Alarm	1
133537	Label – Crushing Hazard	1
228327	Cosmetic – Genie GS-2669RT	2
228328	Cosmetic – Genie GS-3369RT	2
228329	Cosmetic – Genie GS-4069RT	2
228407	Ground Control Panel	1
229427	Label – Outrigger Load	4
229828	Warning – Hot Surface	3

Part No.	Decal Description	Qty
230492	Label - Manual Force, GS-2669	1
230493	Label – Manual Force, GS-3369	1
230494	Label – Manual Force, GS-4069	1
230808	Platform Control Panel	1
230809	Label – Maximum Capacity, GS-2669	1
230810	Label – Maximum Capacity, GS-3369	1
230811	Label – Maximum Capacity, GS-4069	1
T114635	Label – Wheel Load, GS-2669RT	4
T114636	Label – Wheel Load, GS-3369RT	4
T114637	Label – Wheel Load, GS-4069RT	4

# Inspections

## Additional decals for models with outriggers

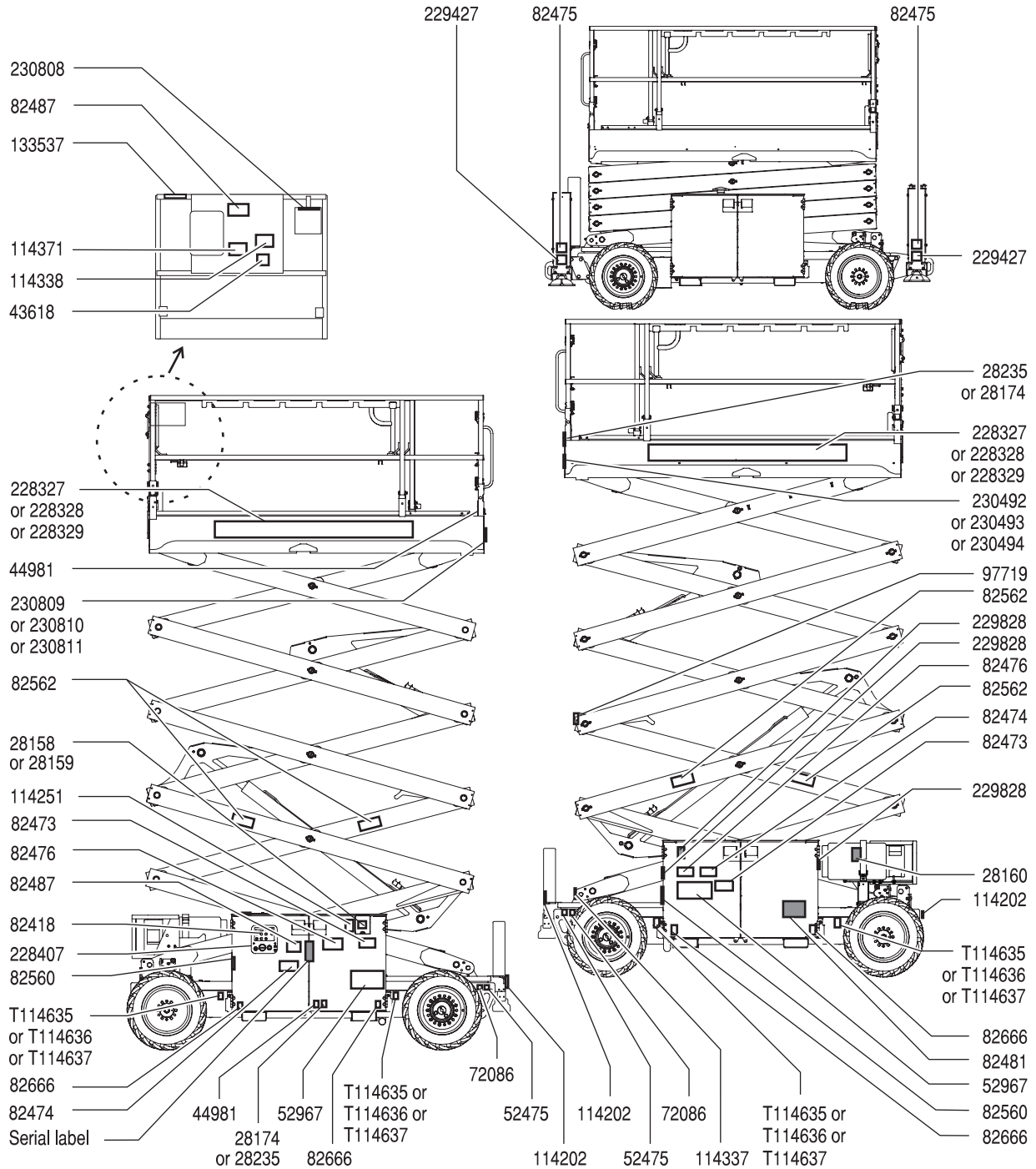

■ Shading indicates decal is hidden from view, i.e. under covers

