



MESSERSI spa

IL GIGANTE BLU
COMPACT TRACK LOADER

03.67.1630

CTL-40T

INSTRUCTION
MANUAL

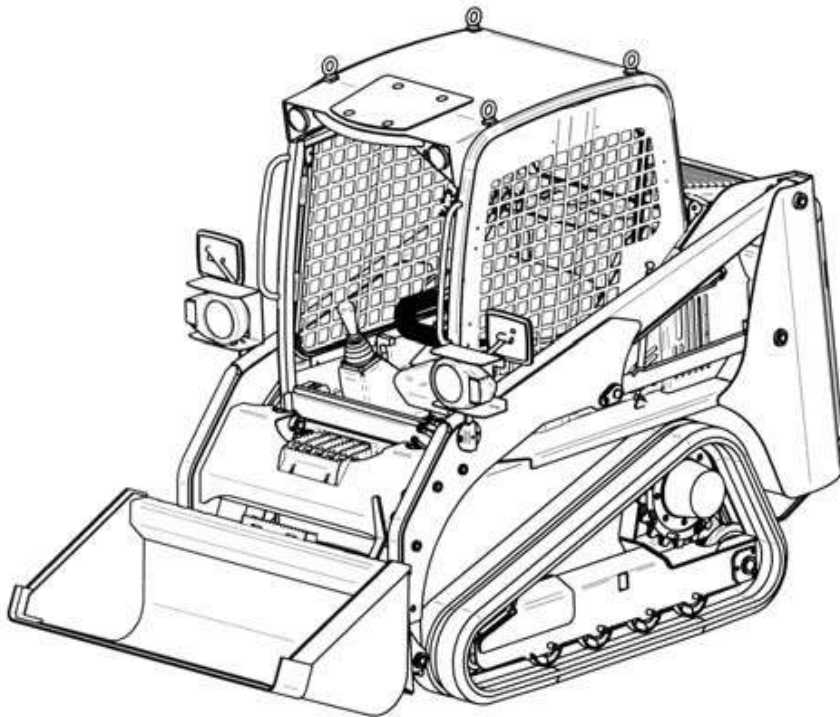

Register N°



Member of CISQ Federation

RINA
ISO 9001:2000
Certified Quality System



Sede Legale: Via Thomas Edison, 6
60027 OSIMO (AN) Italy

Sede Amm. e Stab.: Via Arceviense, 44
60010 CASINE di OSTRÀ (AN) Italy

Tel. (+39) 071 688771 r.a. - Fax (+39) 071 688557

Web: www.messersi.it - E-mail: messersi@messersi.it

- This manual is supplied together with the spare parts manual with each machine.
- The manual was created and formulated in conformity with the EEC regulations and in particular with the **UNI-ISO 6750** regulation.
- The manual supplies information about the operation of the machine, with particular reference to the safety procedures to adopt during its use. Furthermore, it contains useful advice and information for its maintenance.
- The information supplied does not claim absolute working safety, but supplies a reliable basis for its achievement.
- Safety instructions and precautions to be applied in general or in particular are listed in each chapter in correspondence to the operating specifications.
- Please follow the instructions in this manual and scrupulously follow the recommendations. Respecting the procedures will allow operating in absolute tranquillity and safety.
- The company, in its constant search to improve its products, or for reasons of constructive, technical-functional and commercial requirements, reserves the right to modify the machine without the obligation to timely update the sections of this publication involved.
- Designs and texts may disagree more or less obviously with some technical characteristics of the machine; in this case, contact the manufacturer before proceeding.
- In the manual, and if necessary on some parts of the machine, certain symbols are used, followed according to the case by messages inherent to safety. For more attentive and easier reading of these, follow the warnings as described below:

**DANGER**

Where this symbol appears, there is a high degree of danger and risk for the safety and **life** of the operator or other persons. Use all the precautions and measures recommended in this manual and dictated by common sense.

**WARNING**

This symbol, signals the presence of a potential danger which can be avoided by following and respecting the instructions listed in this manual or using the right precautions.



The use of the machine is subordinate to reading and knowledge of this manual with particular reference to the information regarding safety.

This manual must always accompany the machine and must be kept within easy reach of the operator. Other than providing instructions on the proper use of the machine, it guards against risks and dangers deriving from improper use and not in conformity with the use for which it was intended.

CONSERVE THIS MANUAL FOR THE FUTURE REFERENCES

PRESENTATION OF THE MACHINE	Pag. 5
• MACHINE IDENTIFICATION	Pag. 6
• MAIN PARTS OF THE MACHINE	Pag. 6
• CHARACTERISTICS, TECHNICAL DATA AND PERFORMANCE	Pag. 7
• TRANSPORT AND HANDLING	Pag. 9
• PRESCRIPTIONS FOR CIRCULATION ON ROADS	Pag. 12
GENERAL SAFETY REGULATIONS	Pag. 13
• WARNING AND SAFETY DECALCOMANIA AND PLATES	Pag. 14
• GENERAL REGULATIONS	Pag. 14
• SAFETY REGULATIONS FOR STARTING	Pag. 15
• OPERATING SAFETY	Pag. 15
• SAFETY EXITS	Pag. 16
• MOVEMENT ON SLOPES	Pag. 17
• SAFETY REGULATIONS FOR STOPPING AND PARKING	Pag. 18
• FIRE-EXPLOSION PREVENTION REGULATIONS	Pag. 19
OPERATOR CONTROLS	Pag. 21
• DRIVER'S SEAT,	Pag. 22
- SAFETY BELTS	Pag. 22
- SAFETY BAR	Pag. 22
• CONTROL AND AUXILIARY INSTRUMENTS	Pag. 24
• MACHINE STARTING AND STOPPING	Pag. 29
• MOVEMENT AND DRIVING	Pag. 30
• USE OF THE MACHINE	Pag. 34
• TOWING THE MACHINE	Pag. 38
EQUIPMENT AND ACCESSORIES	Pag. 39
• SHOVEL REPLACEMENT OR REPLACEMENT OF OTHER ACCESSORIES PREPARED FOR QUICK FITTING	Pag. 40
• HYDRAULIC POWER TAKEOFF (P.T.O.)	Pag. 41
• DRIVER'S CAB	Pag. 41
• USE OF LIFTING FORKS	Pag. 43
• EQUIPMENT AND EQUIPMENTS	Pag. 44
ORDINARY MAINTENANCE	Pag. 45
• PRELIMINARY INFORMATION	Pag. 46
• LUBRICATION, GREASING: MAINTENANCE SAFETY	Pag. 46
• REFILLING, INSPECTIONS AND CHECKS	Pag. 52
• DRIVE TRANSMISSION	Pag. 55
• BRAKING DEVICES	Pag. 57
• TRACK TENSION CHECKS AND ADJUSTMENT	Pag. 59
• HYDRAULIC SYSTEM	Pag. 62
• ELECTRICAL SYSTEM	Pag. 65
• SUPPLY TABLE	Pag. 68
• MAINTENANCE TABLE	Pag. 69
• TROUBLESHOOTING	Pag. 70
• MAINTENANCE	Pag. 77



PRESENTATION

OF THE

MACHINE



The loading shovel has been designed and built for loading and unloading earth, gravel, sand, debris and other loose material and is however suitable to operate in compliance with the features and performance indicated in this manual.

It is a machine with Diesel internal combustion motorisation with hydrostatic transmission, joy-stick type servo-controls for traversing and manoeuvre of the arms and the bucket.

Movement is obtained using four rubber tracks with suitable tread to operate inside without damaging the floor.

The machine is equipped with an open or closed driver's cabin with heating plant and an incorporated protective structure against tipping **ROPS** and against falling objects **FOPS – 1st level**.

FOPS 2nd level protection can be supplied on request for heavy duty and/or particular use; bolt in replacement of the 4 eye-bolts.

MACHINE IDENTIFICATION

The machine is fitted with a special plate carrying the identification data of the machine, riveted to the left front side of the frame.

For any queries always quote the type and serial number stated on the plate.

For further explanations, please consult the modes on the Spare Parts Manual attached to the machine.

Other accessories which can be installed in the machine will be provided with their nameplate, which can be seen from the external part of the accessory. For further information consult the documentation related to the specific element.

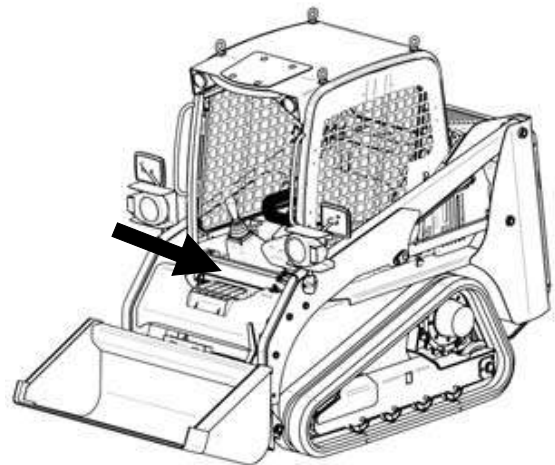

MAIN PARTS OF THE MACHINE

- 1 - Loading bucket
- 2 - Non-slip access steps
- 3 - Safety bar
- 4 - Lifting eye-bolts
- 5 - Cabin ROPS-FOPS
- 6 - Hydraulic oil tank
- 7 - Cowling
- 8 - Diesel tank (RIGHT and LEFT)
- 9 - Lever arm
- 10 - Bucket release and various equipment
- 11 - Handle for ascent and descent
- 12 - Auxiliary power take off (P.T.O.)

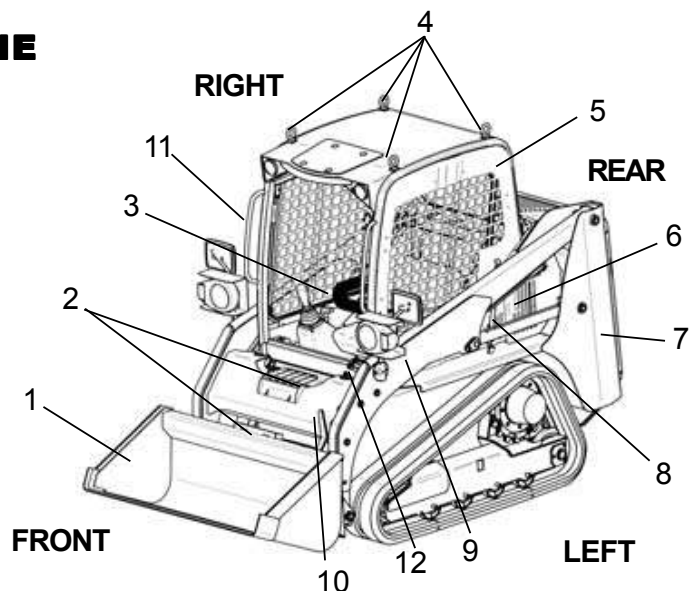

CHARACTERISTICS AND TECHNICAL DATA**ENGINE**

Brand and model	Kubota	V1505T
Calibration Power at 2800 rpm	HP/Kw	41/30
Cylinders	N°	4
Displacement	cm ³	1498
Cooling		water

HYDRAULIC SYSTEM:

Hydrostatic drive with double axial piston pump and variable cylinders connected to two two-speed geared motors, one for each track roller.

Negative braking system on the geared motors

Main variable-cylinder axial piston pump	Lt/min	57.4 x 2
--	--------	----------

Auxiliary gear pump	Lt/min	39 x 1
---------------------	--------	--------

Total capacity	Lt/min	153.8
----------------	--------	-------

Useful capacity for power takeoff (PTO)	Lt/min	39 a 180 bar
---	--------	--------------

Max. operating pressure	bar	180
-------------------------	-----	-----

Hydraulic servo-controls with joy sticks for traversing and manoeuvre of arms and bucket.

Floating electrovalve to adjust the bucket to the ground

Safety electrovalve to block arm descent

Electro-valve for 2nd speed control

Heat exchanger for the cooling of the hydraulic oil.

Hydrostatic steering

FRAME:

Chassis in box-type sheet steel and shaped

RUBBER TRACKS:

Width	mm	250
-------	----	-----

PERFORMANCE:

Weight when fully eupped (including operator)	Kg	2220
Bucket capacity (SAE capacity m ³ 0.245)		
- 35% T.L. (*) ISO 14397/1-2	Kg	400
- 50% T.L. (*) ISO 14397/1-2	Kg	520
(*)T.L.= Tipping Load = Max load permitted by the machine with maximum working radius at tipping limit.		
Tear strength at tooth	daN	930
Lifting force at floor level	daN	1030
Transfer speed I/II	Km/h	4.5÷10
Possible gradient	%	more than100
Specific ground pressure:		
- when empty	Kg/cm ²	0.33
- when loaded	Kg/cm ²	0.40
Autonomy	About hours	8

OVERALL DIMENSIONS

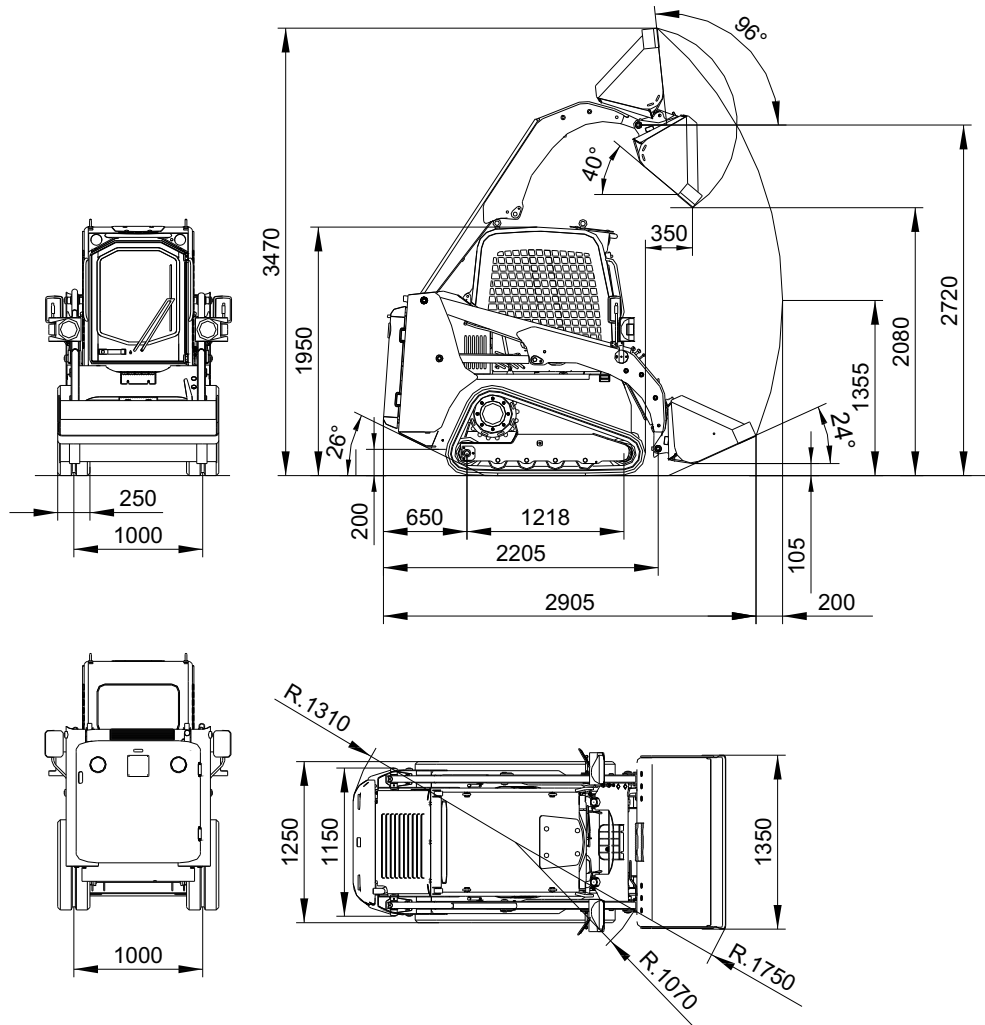

TRANSPORT AND HANDLING

LOADING WITH RAMPS AND TRANSPORT BY TRUCK



The machine loading and unloading operations must be carried out on a compact and level surface.

Check that the transport vehicle is in perfect condition. Apply the hand brake and insert safety wedges at the front and rear of the rear axle tyres.

The vehicle engine must be off and the key removed from the ignition. The body must be level. Position the machine at the rear of the truck, ensuring that the longitudinal axle coincides with that of the truck.



Check that the ramps are suitable for the vehicle to be loaded. **Only use homologated and/or certified ramps.**

Check that **the ramps are perfectly clean and free of grease** and that there is no risk whatsoever of the tracks .

Check that the ramps are long enough to avoid problems during ascent and descent of the machine. The length of the ramps must be such that their inclination with respect to the height of the truck loading platform is between 15° and 16°.



Check that **the ramps are properly coupled** to the transport vehicle and appropriately spaced.

The width of the ramp must be such as to allow comfortable passage of the tracks .

The ascent and descent operations must always be carried out with the machine running and the hydraulic oil at operating temperature.



Do not use the ramps as a gangway for crossing from one vehicle to the next.

For loading and unloading of the machine it is recommended to ascend in reverse gear and descend in forward gear. In both cases it is recommended to keep the arm lowered and the bucket turned downwards, parallel to the ramps. Block the eventual lowering of the loading platform with a truss or other equipment.



Before ascending or descending, check perfect alignment between the tracks and the ramps. **Do not steer or adjust direction while on the ramps.** If necessary, return to the point of departure, repositioning correctly.



Caution of passage in the connection area between the ramps and the loading platform of the truck; the steep slope must be negotiated by moving very slowly and with extreme caution. Be twice as careful in the descent phase since the unbalance towards the bottom in this case is much higher. It is recommended to lower the arms and turn the bucket forwards to allow eventual emergency shutdown.

All the loading and unloading operations of the machine must be carried out and coordinated by at least a second person who controls good progress of the operations.

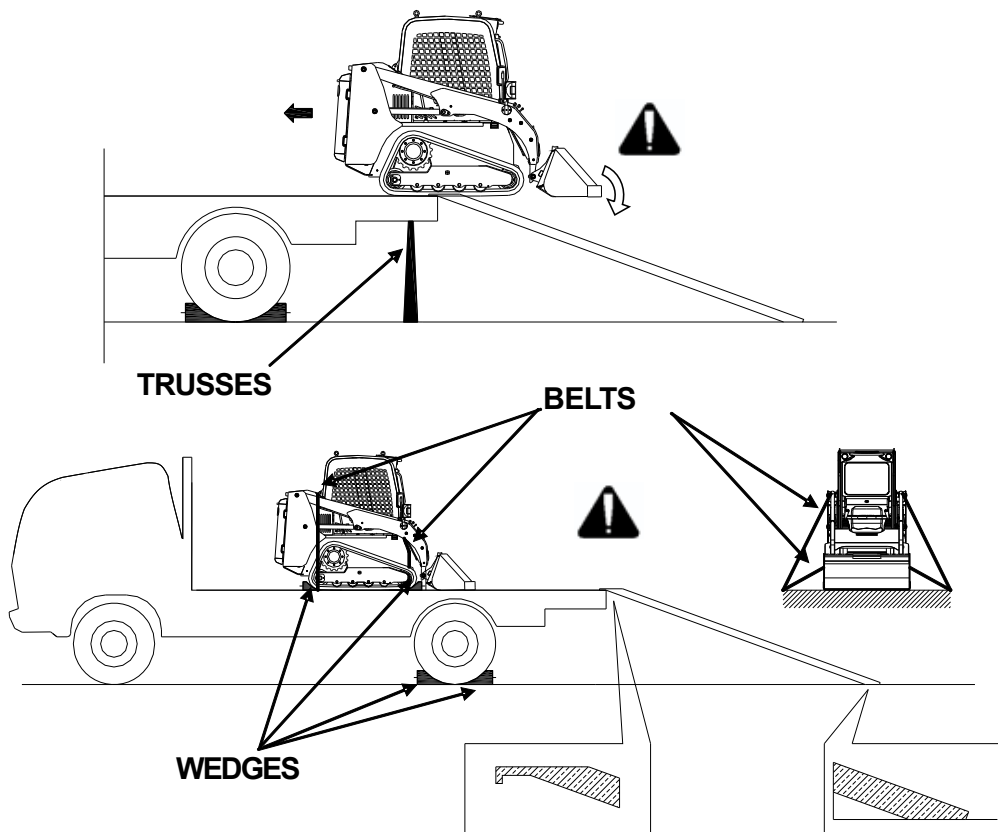

TRANSPORT

Once the machine has been positioned on the load plane, lightly rest the bucket and proceed to blocking the machine lengthwise by inserting wedges in front of and behind the track rollers.



For transversal and vertical blocking use belts to prevent lateral and vertical movement owing to jolts during transport.

Measure and check the maximum height of the load. During transport always follow the road regulations and the specific regulations in force in the various countries of transit.

LIFTING

Check that the cabin is correctly fixed to the frame before lifting the machine.

Use the 4 supplied eye-bolts to lift the machine, by fixing them to the special seats located on the roof of the cabin.



If the eyebolts are removed, close the four seats with the plastic caps supplied. Any infiltration of water could seriously damage the electrical system of the right-hand and left-hand dashboard.

Restrict the lifting area, prohibiting access to foreign personnel. Do not pass over persons or things and ensure that the loading area is free of any obstacles (electric and telephone cables, etc.).



IT IS STRICTLY PROHIBITED TO WALK OR STAND UNDER THE SUSPENDED LOADS.

- Use cables or chains with adequate capacity for the load to be lifted.
- Attach the ropes or chains to the previously bolted eye-bolts and proceed with lifting avoiding sudden movements and dangerous machine swaying.
- During transport follow the instructions previously recommended.

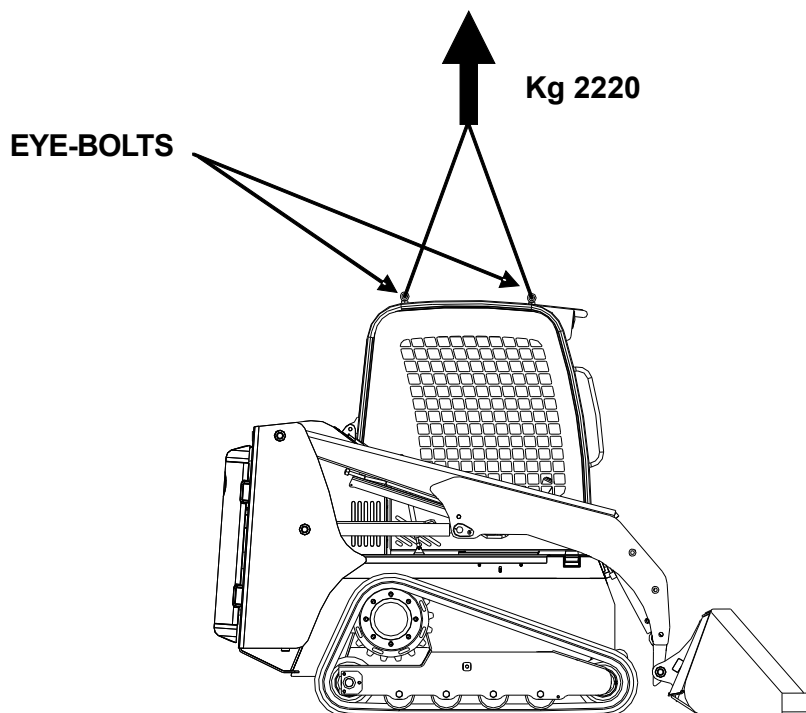

PRESCRIPTIONS FOR CIRCULATION ON ROADS

For correct road circulation comply to all specified below.

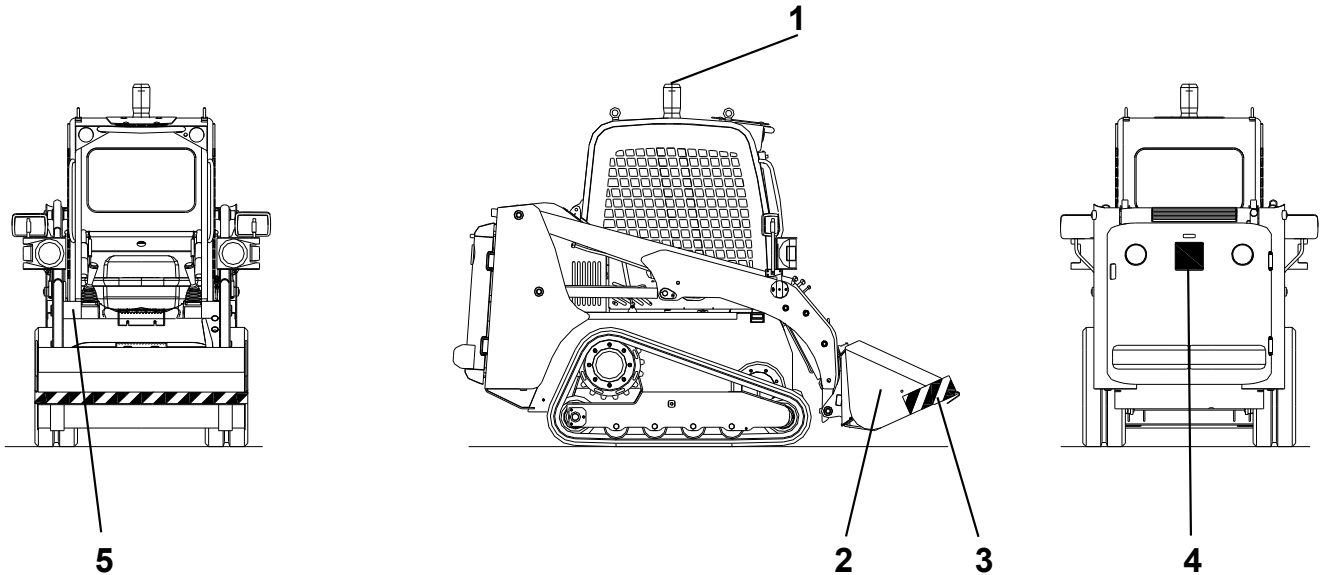

- 1 - Flashing lights.
- 2 - Shovel blocking pin in maximum lifting position
- 3 - Shovel sharp edge lateral and front protections.
- 4 - Plate positioning.
- 5 - Frame number punching area.

PRESCRIPTIONS

- Working system commands must be blocked. Involuntary lifting of arms is prevented by the hydraulic block inserted on start-up of the machine. Disconnection and insertion is controlled by a button (ref. 4) on the right command panel.
- Obligation for approved yellow flashing light. This functions even when the use of a lighting device is not obligatory.
- Front loading shovel in max. lifting position and blocked to the frame using the special retainer.
- The shovel's sharp edge must be protected by a special protection indicated with red and white reflective stripes.
- The working lights must always be switched off.
- In each case the prescriptions inserted into the vehicle registration document and in the Highway Code must be respected.

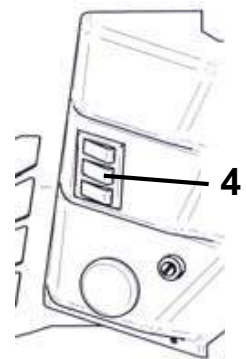

The page features a decorative design with a light gray horizontal bar at the top and a dark gray vertical bar on the left side. A second light gray horizontal bar is at the bottom, with a dark gray vertical bar on the right side. The text is centered between these bars.

GENERAL SAFETY REGULATIONS

SAFETY REGULATIONS FOR STARTING

The machine must only be driven by qualified staff that are at least 18 years old. Before getting on, inspect the machine.

To enter or exit the cabin it is advisable to always turn towards the vehicle.

Use the steps and the handles. Do not jump and do not use the controls as supports.



Before starting the machine, check, adjust and lock the seat into position to ensure maximum driving comfort and ease of handling of the controls

It is recommended to hoot before starting to move and manoeuvre.

OPERATING SAFETY

Never operate the machine in closed environments, unless there is an efficient system for suction and discharge of flue gas.

Before using the machine, ascertain that all the safety devices are in place and in working order. Poor visibility may cause accidents. Keep the windows clean and use the lights for better visibility. Do not use the vehicle in reduced visibility conditions.

Do not use the machine before the hydraulic system oil has reached the appropriate temperature. It is recommended to drive the machine at 60-70% of its power for the first 100 hours.



Before starting to drive or activate the equipment, ensure that there is nobody in the surrounding working area. Should anyone enter into the manoeuvring zone, stop the machine.



On carrying out work on site, the overall height and width of the machine must always be taken into consideration. The loading limits of the land, floor, ramps, etc. on which is to be operated must be known.

Whenever possible, avoid crossing or going over obstacles: large irregularities in the ground, rocks, felled trunks, steps, ditches, jumps and paths may cause the machine to tip-over.

- During transport or operation in proximity of high-tension wires, the safety distance must be respected.
- Do not transport persons on the machine.
- Do not use the bucket to lift or transport persons.
- For safety reasons, do not try to climb on or of the machine while it is moving.
- In case of fire, do not extinguish with water. First of all, use the fire extinguisher, smother the fire with sand or earth, or better, cover the fire with a blanket or cloth.
- When driving the machine pay particular attention to the condition of the ground; moderate speed in the case of rain, snow or ice.



The machine must be driven and manoeuvred only from the driver's seat, in a seated position with the safety bar lowered and with safety belts fastened.

EMERGENCY EXIT



In case of **EMERGENCY** the operator can use n. 2 escape routes. These are the front opening and the rear window of the driver's cabin.

REAR WINDOW:

To remove the glass pull the relative peg (**ref. 1**) positioned on the central part of the rubber seal and remove the insert it includes. Push the glass towards the outside with force (**ref. 2**) and exit from the vehicle.

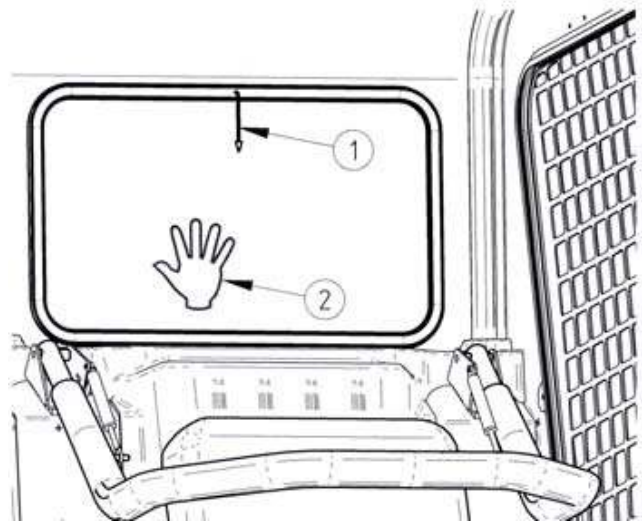

The rear window safety exit is **not suitable** for use in environments where **polar clothing is required**.

N.B.: In machines equipped with a front door, which also becomes an emergency exit, act as follows:

Pull the special peg (**ref. 3**) positioned in the upper central part of the glass seal, push the glass out using the feet (**ref. 4**) and exit from the vehicle.

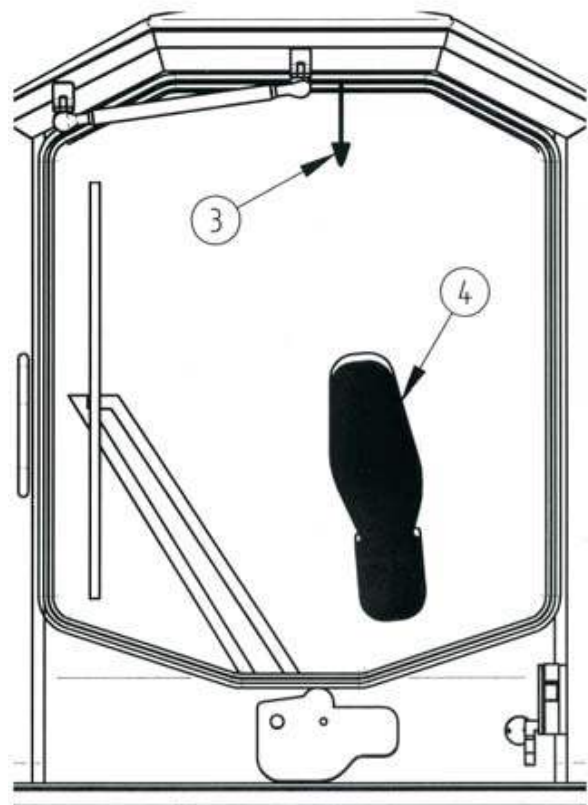

MOVEMENT ON SLOPES



Movement on slopes and craggy areas must be carried out with caution; a high risk exists for the operator and whoever is working in the area. To limit risks to a minimum follow the indications below.

- The loaded shovel must always be upstream, both in ascent and in descent.
- The empty shovel must always be downstream, both in ascent and in descent.
- The load must always be as low as possible.
- Avoid travelling over land where lateral and longitudinal slopes are both present.
- Never pass across slopes.
- Ascent and descent must be carried out by following the slope in a straight line and not at an angle or in an oblique manner.

MOVEMENT

WITH LOADED SHOVEL

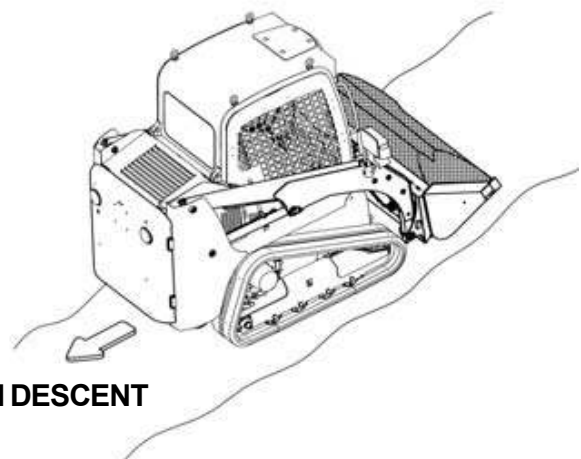
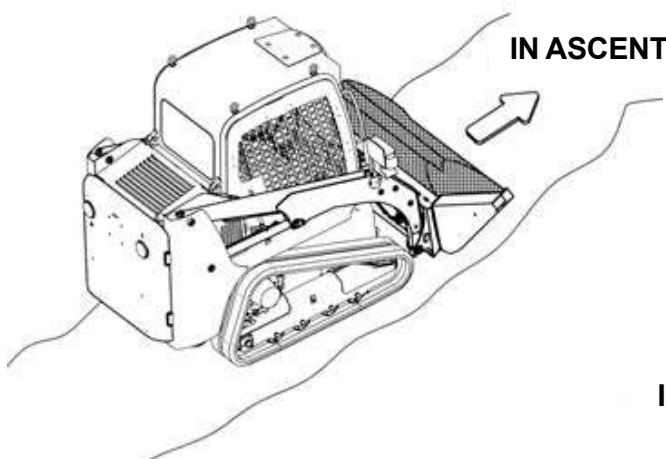

WITH EMPTY SHOVEL

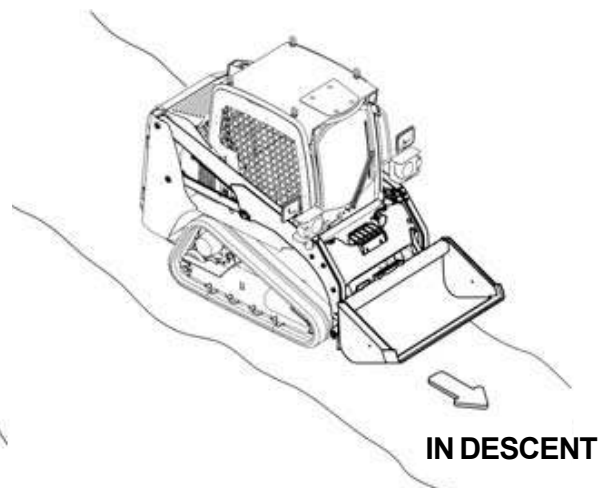
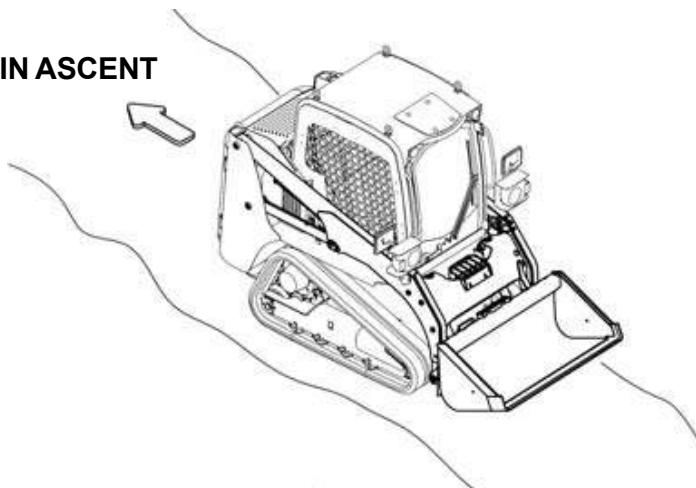

SAFETY REGULATIONS FOR STOPPING AND PARKING



Never leave the machine with the engine running.

After leaving the driver's seat, and after ascertaining that there are no persons near the machine, slowly lower and rest the equipment on the ground. Set the controls in the rest position.

If possible, park the machine in an area where no other machines are operating and where there is no vehicle traffic.



Select a solid and level surface. If this is not possible, arrange the machine in a position transverse to the slope, ensuring that there is no danger of sliding.

In public places or when visibility is reduced, place barriers around the machine to keep persons away.

MAKING THE LIFTING ARMS SAFE



If the machine malfunctions or blocks with the arm raised it is necessary to make them safe, by bringing them to the ground.

This is a very delicate operation that must be carried out by following the indications below.

- 1- The operator **must remain seated**, with safety belts fastened.
- 2- The area around the machine **must be completely cleared of people**.
- 3- Move the key inserted in the ignition commutator to position "1" (Ref. 2).
- 4- Press the lifting arms safety activation deactivation button (Ref. 4).
- 5- Successively press the lifting arms fluctuation button (Ref. 5) and the lifting arms descend immediately

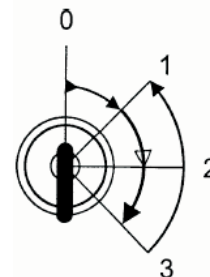
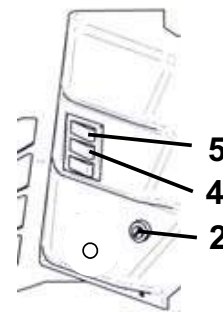

**RANGER OF SHEARING
RANGER OF CRUSHING
FATAL INJURIES**



ATTENTION

In case of EMERGENCY it is possible to block arm descent by pressing the same button again (Ref. 5). **This operation must be carried out exclusively to make the lifting arms safe.**

FIRE-EXPLOSION PREVENTION REGULATIONS

Flames or sparks can cause the battery and fuel to explode and therefore set fire to the machine. To avoid and prevent the causes please follow the advice given below.

Equip the machine with an extinguisher. After any use, reload or replace it. The extinguisher must always be in perfect working order.

- Do not short-circuit the battery clamps with keys or metal objects; any sparks could initiate flaming of the machine's fuel, oils and lubricants.
- Do not weld, grind, smoke or light flames near to the battery or fuel tank.
- When replacing the battery follow the indications supplied in the relative chapter.
- Always keep the machine clean and check any type of leak that may occur.
- Check efficiency and integrity of the electric plant – possible cause of starting a fire.
- Always clean the machine well after use as deposits of inflammable debris, in contact with the hot parts of the machine, could increase the fire risk. The risks increase if this debris is in contact with the exhaust box or near to the hot parts of the engine.



Do not use the machine in environments where dusts and gas are present, or in a generally inflammable atmosphere or when the machine's exhaust pipe can come into contact with inflammable substances.



DANGER OF FIRE-EXPLOSION



OPERATOR CONTROLS



DRIVER'S SEAT



The driver's seat must **not** be adjusted while the vehicle is moving.
Danger of accidents!

Always fasten the seatbelts.

The driver's seat is important for good health. Therefore it must be maintained integral.

The driver's seat can be adjusted longitudinally using the special lever positioned low on the right hand side.

SAFETY BELTS

FASTENING:

Sit properly in the driver's seat, adjust the belt length, check that it is not twisted, then insert the clip **A** into the housing **B** until locked.

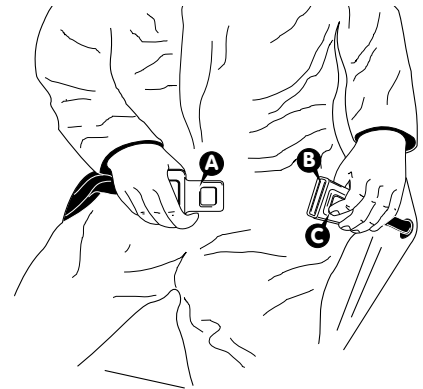

UNFASTENING:

Press the button **C** and remove the belt from the fixed part placing it to the right of the driver.

SAFETY BAR

Every machine is equipped with a safety bar that together with the safety belts and cabin in compliance with ROPS and FOPS makes up the operator's "safety girdle".

The machine must always be driven with safety bar lowered and safety belts fastened.

FUNCTIONS OF THE SAFETY BAR

A - SAFETY BAR RAISED:

- Start-up of the diesel engine
- The servo-controls are deactivated
- The lifting arms are blocked

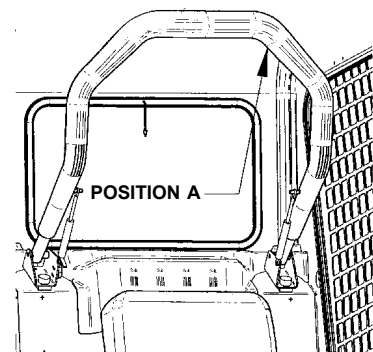

B - SAFETY BAR LOWERED:

- The diesel engine **does not** start-up
 - The servo-controls are activated
 - The arm control is deactivated.
- For activation of the arm control (ascent/descent) press the button (Fig.1 - ref.4)

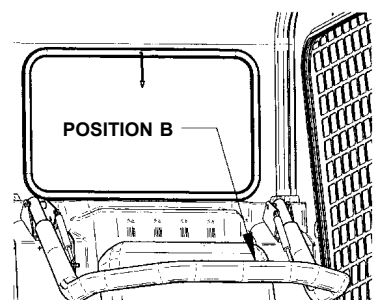

ATTENTION

If the safety bar rises the hydraulic servo-controls are deactivated and the lifting arm blocked.

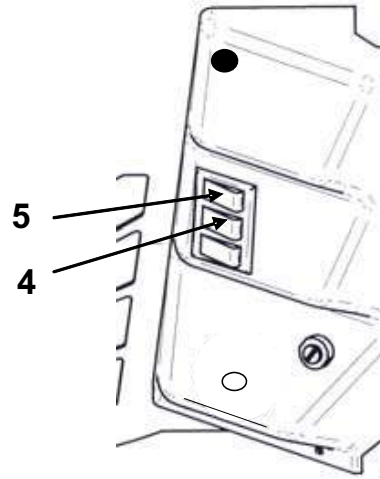

CONTROL AND AUXILIARY INSTRUMENTS

CONTROL PANEL

Fig. 1

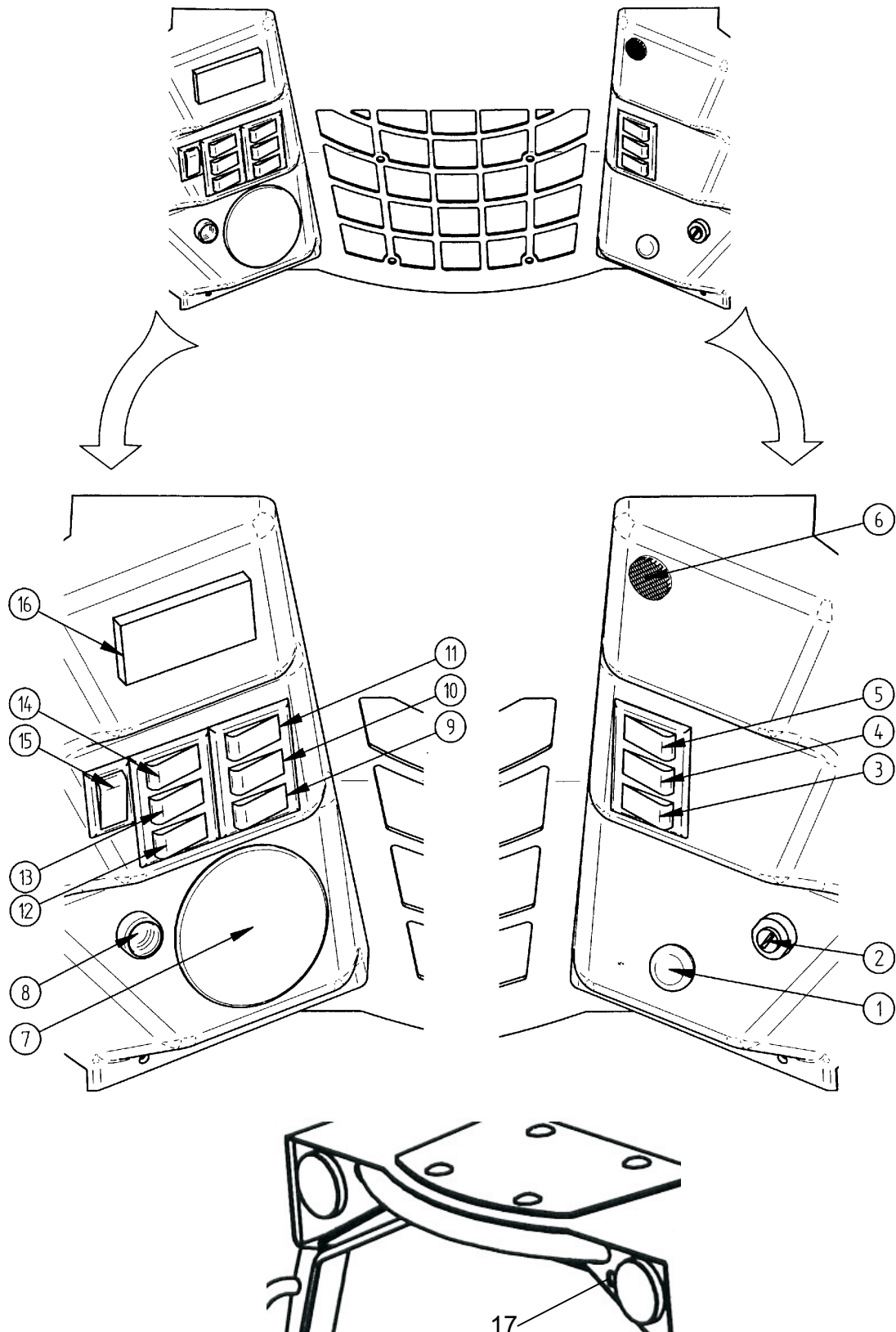

1 - FUEL LEVEL INDICATOR

- Switching on of the warning light signals the entry into the use of reserve fuel, which allows a residual autonomy of about 1 hour.

2- KEY IGNITION SWITCH

To start the machine proceed as follows:

- a- Insert the key in the ignition switch (**Ref. 2 of fig.1**) and turn clockwise to position "1" (panel on).
- b- Wait for the spark-plug pre-heating warning light (**rif. 7.3**) to switch off.
- c- Continue to turn the key to position "3", passing position "2" with a slight pressure. Thus starting has been completed.
- d- After starting, the key automatically returns to position "1".
- e- In case of failed starting, turn the key back to position "0" and repeat the operation from the beginning.

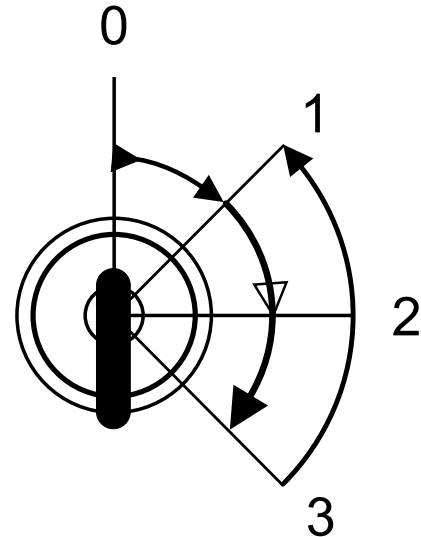

3- POSITION PIVOTED SWITCH FOR POWER TAKE OFF (P.T.O.) CONTROL

INSERTED: Deactivates the command on the RIGHT manipulator

4- LIFTING ARM SAFETY ACTIVATION AND DEACTIVATION SWITCH

ALWAYS insert with the engine switched on and the safety bar lowered. Press it again for deactivation.

5- 2-POSITION SWITCH WITH MECHANICAL INTERLOCK FOR ACTIVATION OF LIFTING ARM FLUCTUATION FUNCTION

(ROUND LEVELLING; can only be activated with the button (ref.4) inserted).



**RANGER OF SHEARING
RANGER OF CRUSHING
FATAL INJURIES**



This switch MUST only be used with the arms and bucket on the ground. Activation with the arms raised consents to the immediate fall of the entire arms-bucket unit with very serious risks.

6- ENGINE COOLING LIQUID HIGH TEMPERATURE ALARM BUZZER

The engine shuts down with the warning light switched on. Check the level of the cooling liquid inside the radiator. Do not re-start until the cause of overheating has been identified.

7- CHECK AND CONTROL INSTRUMENTS

The following warning lights are housed in the instrument as well as the timer:

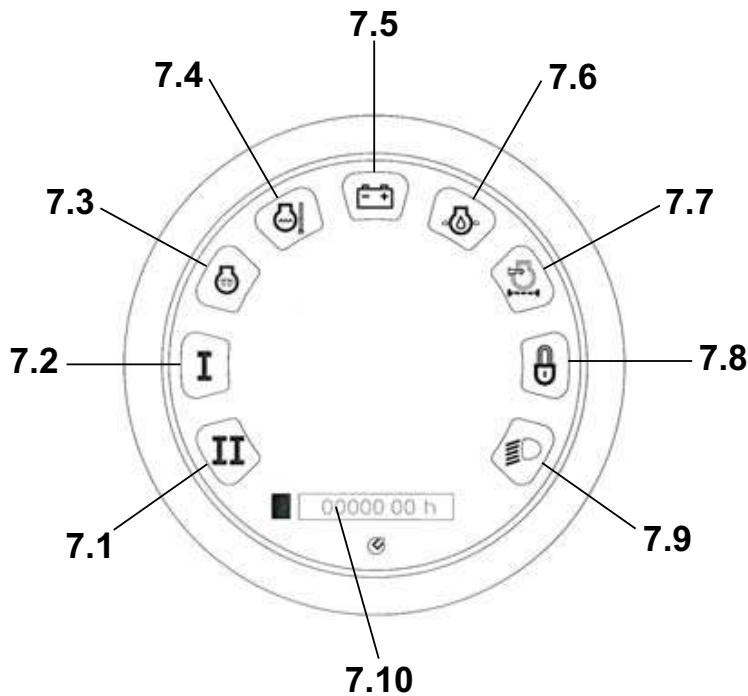

7.1 – POWER TAKE OFF INSERTION WARNING LIGHT (PTO)

7.2 – POWER TAKE OFF INSERTION WARNING LIGHT (PTO)

7.3 – GLOW PLUGS PRE-HEATING INDICATOR

The warning light switches on after clockwise rotation of the key in the ignition block. The machine must always be started-up after the warning light switches off.

7.4 – ENGINE COOLING LIQUID TEMPERATURE WARNING LIGHT

The warning light signals anomalous functioning of the diesel engine cooling plant.

7.5 – GENERATOR CHARGE INDICATOR

- **OFF** in normal operating position
(goes off immediately after starting)
- When **ON** it signals malfunctioning in the battery recharging system.

7.6 – ENGINE OIL PRESSURE INDICATOR

- When this indicator comes on, it signals malfunctioning in the diesel engine lubrication system
- insufficient pressure or lack of oil. Immediately stop and identify the cause.

7.7 – AIR FILTER CLOGGED INDICATOR

When the indicator is on, it signals inefficiency of the suction system - filter cartridge clogged.

7.8 – HYDRAULIC SERVO-CONTROL BLOCK WARNING LIGHT

SWITCHED ON: Hydraulic commands deactivated (safety bar raised).

SWITCHED OFF: Hydraulic commands activated (safety bar lowered).

7.9 – HEADLAMP INSERTION WARNING LIGHT**7.10 – HOUR COUNTER**

Signals the progressive working time. Functions with the engine running.

8 – 12V UNIPOLAR OUTLET

Allows low-tension fitting usage.

9 – EMERGENCY LIGHT SWITCH

Controls the simultaneous functioning of the four direction indicators.

Insert the switch every time a potential danger exists and in EMERGENCY situations.

10 – FLASHLIGHT DEVICE SWITCH

Commands the device positioned above the cabin connected through a plug at the side of the left working light. **ALWAYS SWITCHED ON DURING CIRCULATION ON ROADS**

11 – WORKING LIGHT SWITCH

Commands the working lights situated on the front part of the cabin.

12 – AVAILABLE (WINDSCREEN WIPER COMMAND ON MACHINES EQUIPPED WITH CABIN FRONT DOOR)**13 – AVAILABLE (HEATING FAN COMMAND SWITCH (2 SPEED) IN MACHINES EQUIPPED WITH HEATING PLANT)****14 – 3-POSITION SWITCH FOR LIGHTING PLANT CONTROL (POSITION AND HEADLIGHTS)****15 – THREE-POSITION SWITCH FOR DIRECTION INDICATOR COMMAND**

FORWARD: turn left

CENTRAL: neutral

BACKWARD: turn right

16 – FUSE BOX

- F1 – Switch and warning light protection fuse (7.5A)
- F2 – Flashing light + working lights protection fuse (15A)
- F3 – Heating fan protection fuse (10A)
- F4 – Windscreen wiper protection fuse(10A)
- F5 – Safety bar and services micro protection fuse(10A)
- F6 – Acoustic warning + reverse gear warning protection fuse (7.5A)
- F7 – Power take off (PTO) protection fuse (10A)
- F8 – Alternator excitement protection fuse (5A)
- F9 – Engine shutdown protection fuse +30 (15A)
- F10 – Radio and emergency lights protection fuse +30 (10A)
- F11 – Position lights right line protection fuse (5A)
- F12 – Position lights right line Position lights right line + number plate light protection fuse (5A)
- F13 – Headlights protection fuse (10A)
- F14 – Protection fuse +15 and stop lights (5A)

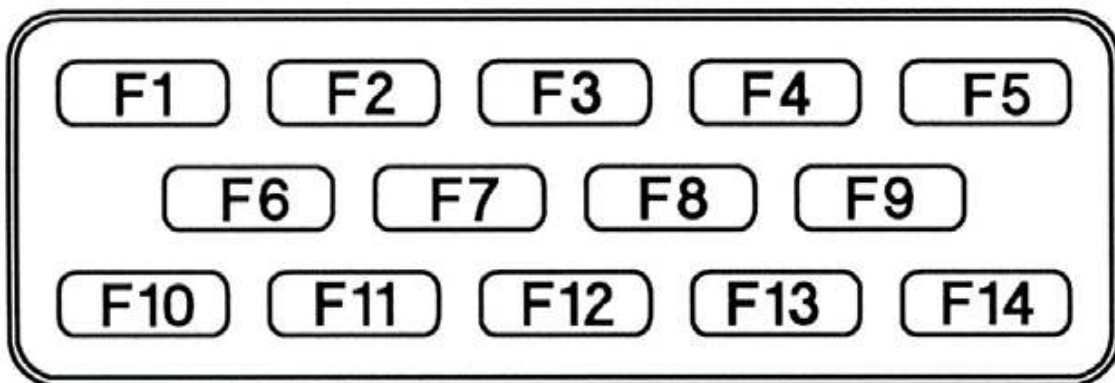
**17 – 12 V UNIPOLAR SOCKET FOR ATTACHMENT TO FLASHING LIGHT**

MACHINE START-UP AND SHUTDOWN

- Operator correctly positioned inside the driver's cabin for use of the machine both in the transfer phase and for working.

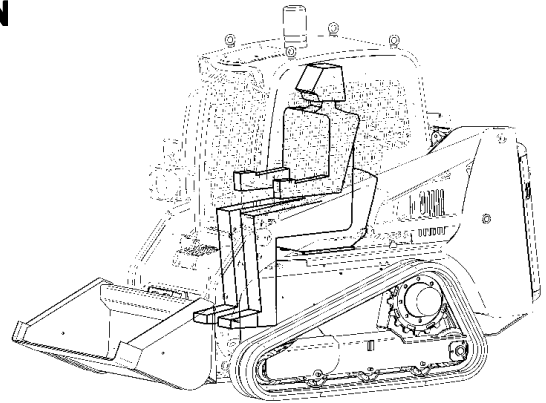

STARTING

- For proper starting follow the instructions described above and as indicated below.
- Once the engine has started, gradually move the accelerator (Ref. LA) lever to the idle position, at a sufficiently low rpm and avoiding sudden acceleration, until the hydraulic system has reached the operating temperature (5 ÷ 10 minutes depending on the atmospheric conditions and climatic).



 **Start-up can only be carried out with the safety bar raised, Position "A"**

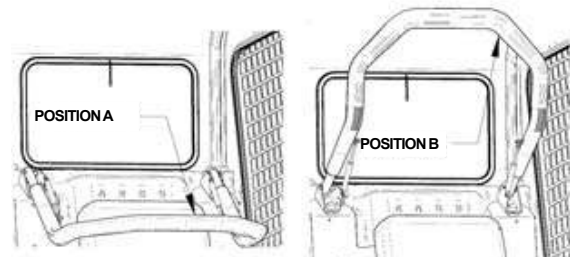

Do not allow unauthorised persons to drive the machine. Remember that the responsibility for the machine lies with the person who has received it.

 Do not start using the machine until sure of its functioning. It is a good rule to practice in an open and clear area when manoeuvres in which experience is lacking need to be carried out. Concerning driving of the machine follow the instructions as described below, remembering which is the front side of the machine.

STOPPING

 To stop the engine it suffices to turn the key (Fig.1 - ref. 2) anticlockwise. It is advisable to idle the engine for a few minutes before stopping the machine. Remove the key whenever leaving the driver's seat. Never leave the machine running and unattended.

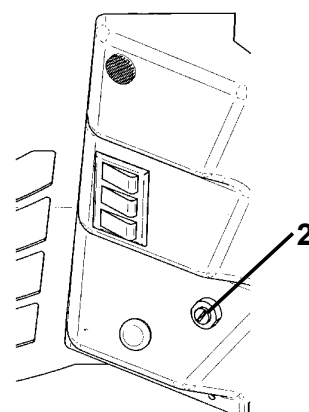

MOVEMENT AND MARCH:

MOVEMENT

Traversing of the machine is controlled by the left joy-stick. The various joy-stick positions, depending on the manoeuvre to be carried out, are represented below.

STRAIGHT LINE MOVEMENT

Position **A**: **FORWARD** movement

Position **B**: **REVERSE** movement (an acoustic safety device is activated)

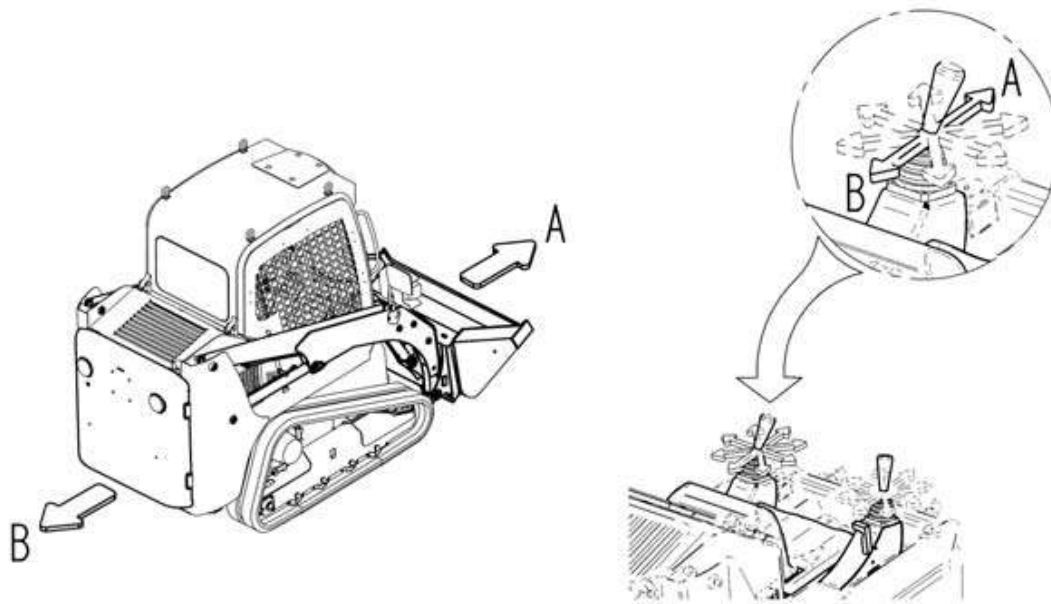

CHANGE OF DIRECTION

Position **F**: **90° RIGHT TURN**

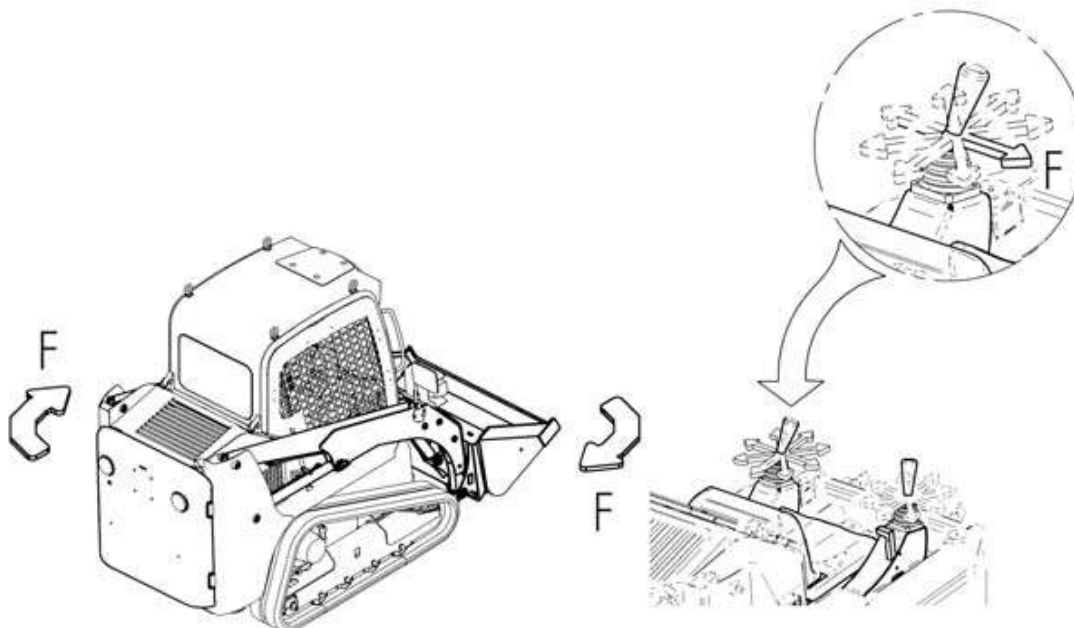

Position **H**: **PROGRESSIVE RIGHT TURN IN FORWARD MOVEMENT**

Position **G**: **PROGRESSIVE LEFT TURN IN REVERSE MOVEMENT**

(an acoustic safety device is activated)

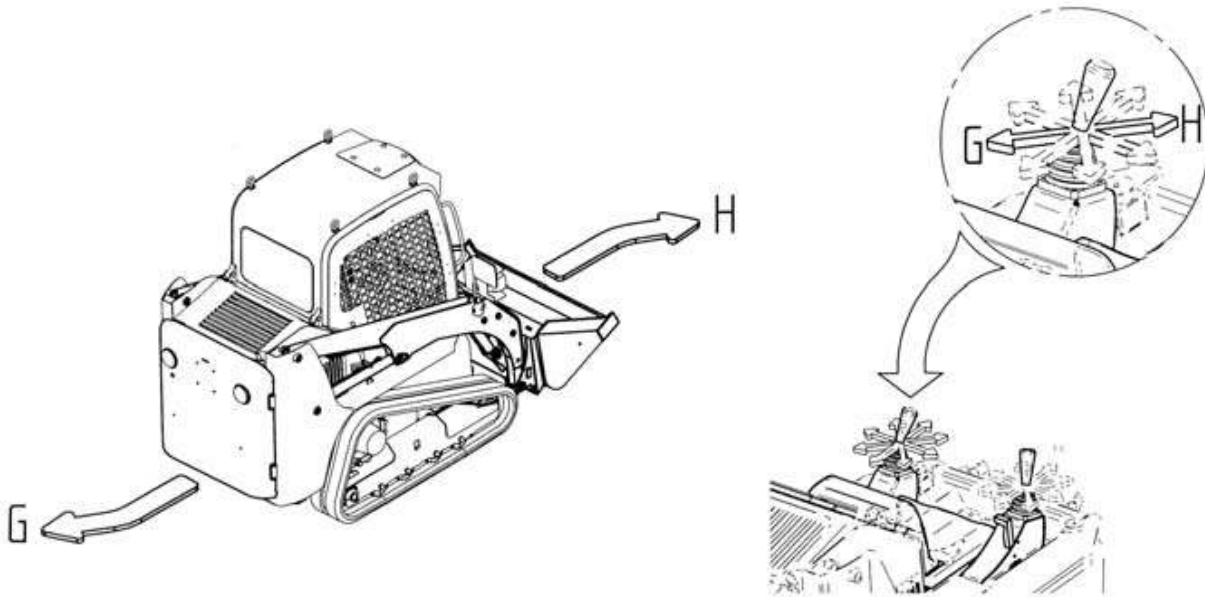

Position **E**: **90° LEFT TURN**

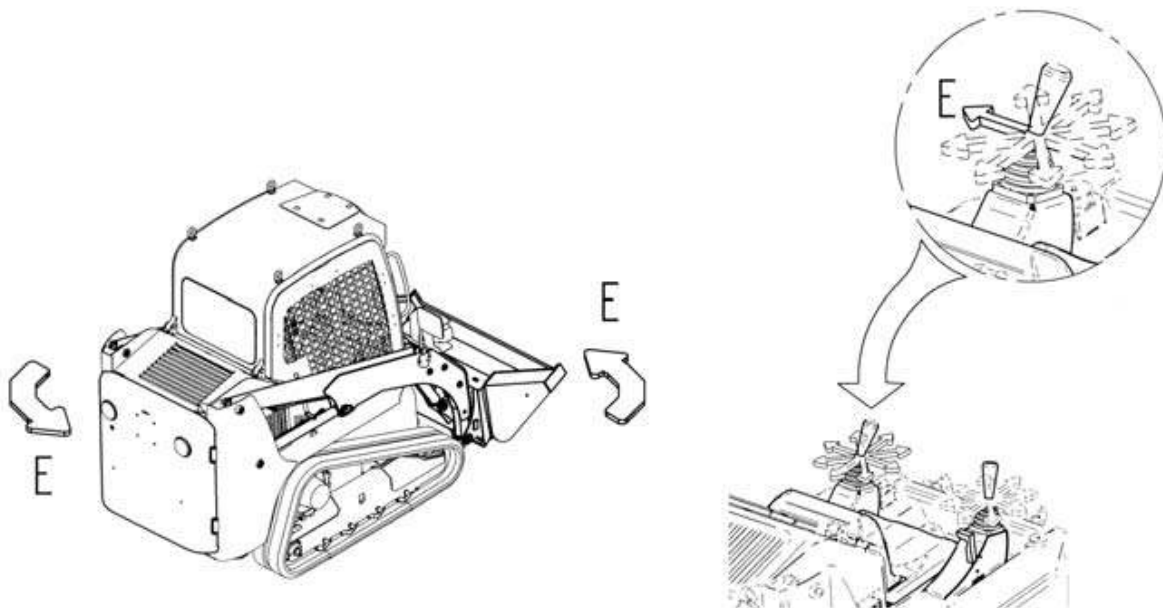

Position **C**: **PROGRESSIVE LEFT TURN IN FORWARD MOVEMENT**

Position **D**: **PROGRESSIVE RIGHT TURN IN REVERSE MOVEMENT**

(an acoustic safety device is activated)

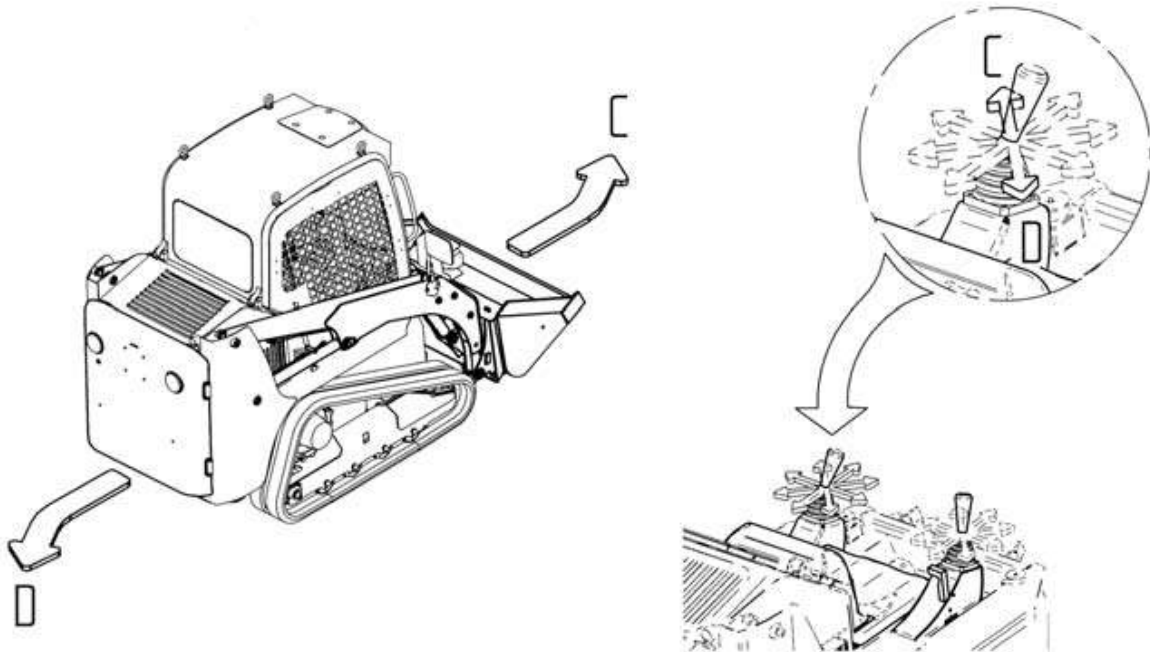

CONTROL OF THE LIFTING ARM

Position **I**: **ARMS DESCENT**

Position **L**: **ARMS ASCENT**

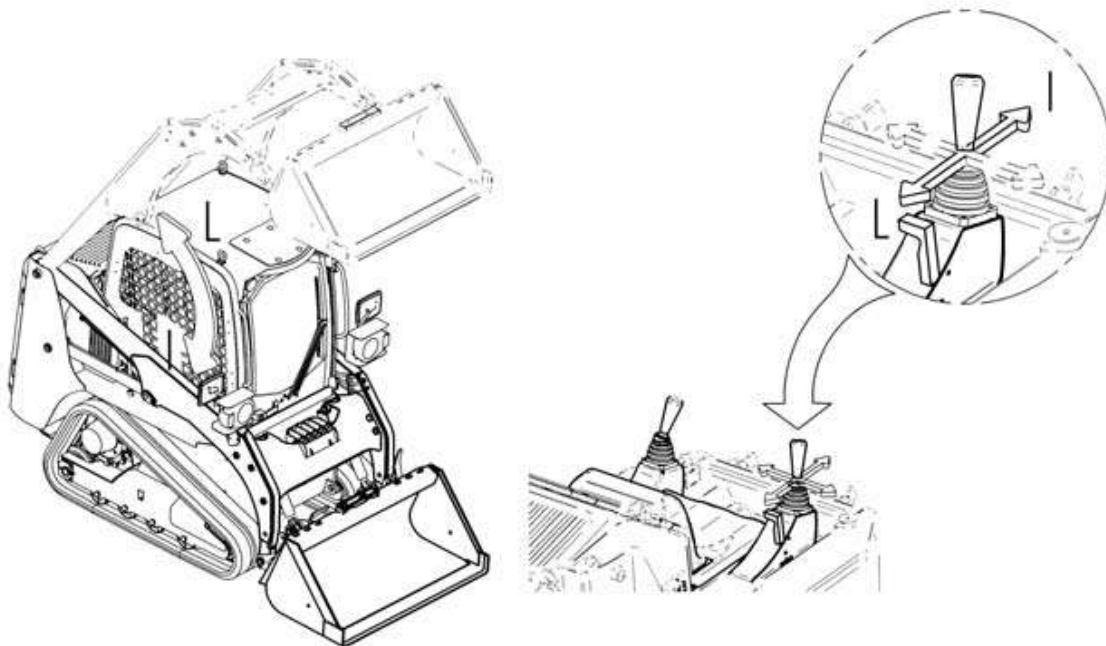

SHOVEL CONTROL

Position **M**: SHOVEL CLOSURE

Position **N**: SHOVEL OPENING

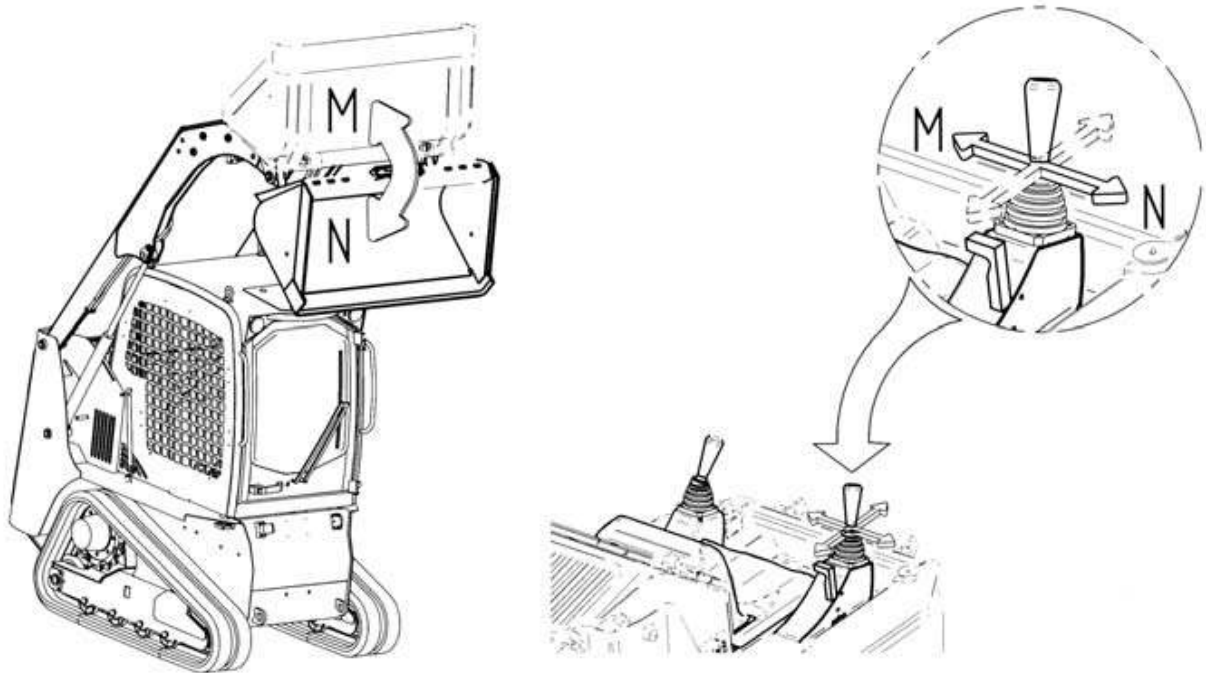

COMMANDS ON RIGHT AND LEFT JOY-STICK GRIP

O: HORN control button

S: Insert fast speed button

T: Insert slow speed button

P,Q: Power take off P.T.O. control button

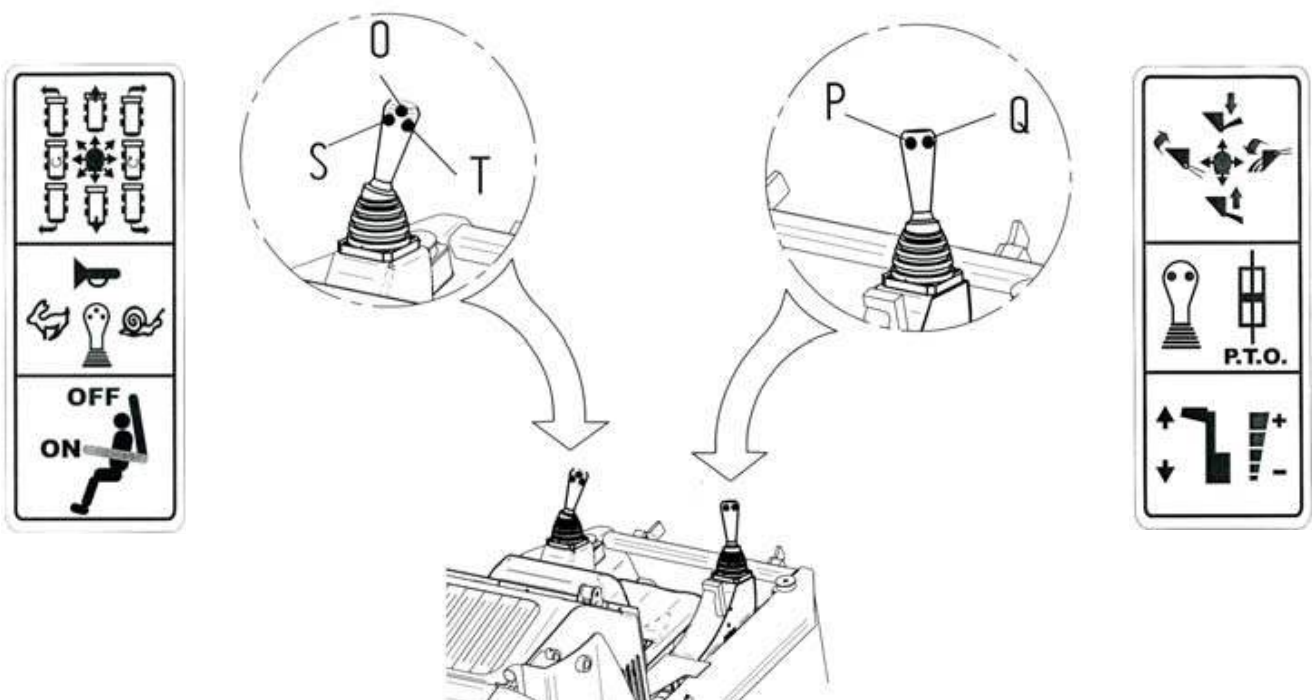

USE OF THE MACHINE

FILLING AND EMPTYING OF THE SHOVEL

FILLING

To fill the shovel follow the warnings below:

- 1 - Lower the lifting arms completely.
- 2 - Turn the shovel until it touches the ground slightly with the point slightly inclined forwards
- 3 - Advance slowly penetrating the stock pile and at the same time turn the shovel backwards until it is completely filled.
- 4 - Raise the lifting arms to just above the stock pile.
- 5 - Pull back, lower the lifting arms and move, with the shovel low, towards the place of unloading.

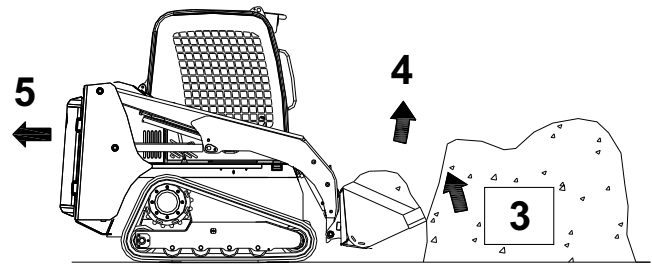
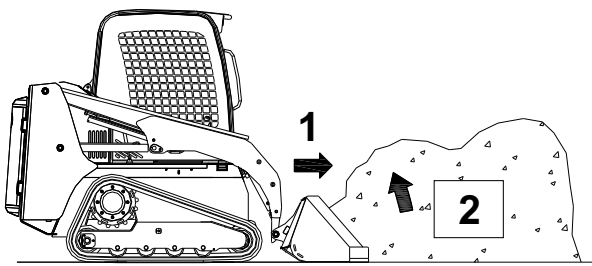

EMPTYING

During transfer to the unloading area the shovel must be positioned as low as possible and in maximum collection position.

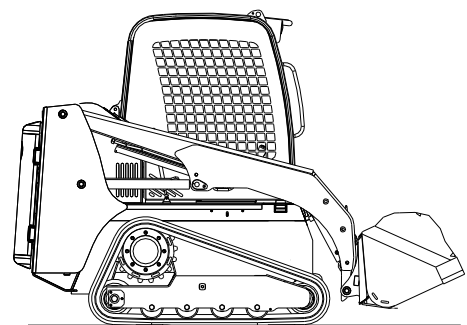

Transfer must be carried out at a moderate speed.

Move as near as possible to the vehicle to be loaded keeping in mind that the shovel's trajectory lengthens during lifting.

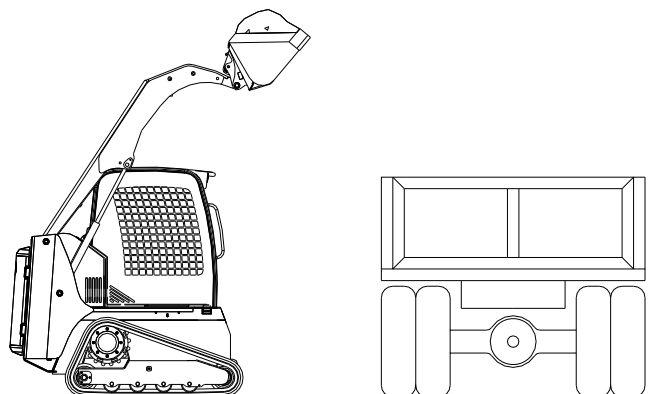

During the arm lifting phase, incline the shovel slightly forward and try to hold it as horizontal as possible to prevent loss of the load (**machine without lifting control valve, self-levelling**).

With the shovel in high position, move near to the vehicle to be loaded and turn the shovel forwards to carry out complete unloading. If the shovel should not empty completely, open and close the shovel alternately to help the material to escape.

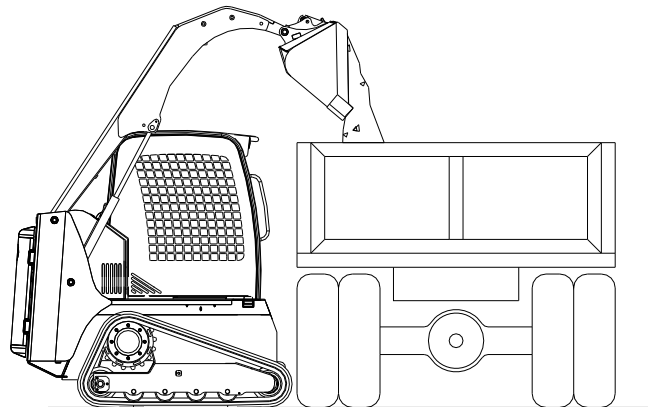

LEVELLING THE GROUND

The machine is equipped with a **floating valve, which** renders the lifting arms “idle”. This function is very important for levelling the ground as the arms and the bucket always follow the course of the ground and, with repeated operations, it is possible to flatten and level material of the desired thickness parallel to the ground.

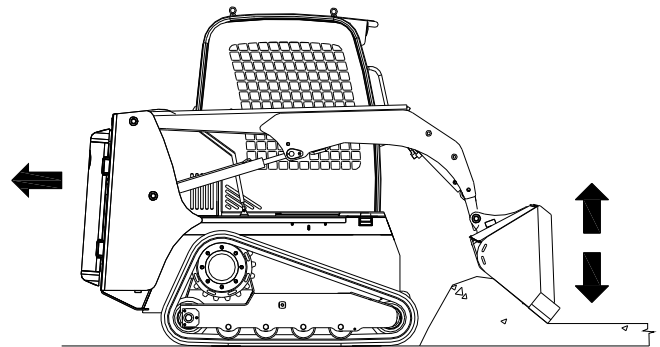

Raise the lifting arms inclining the shovel forward until obtaining an angle of 45° between the base of the shovel and the ground. The end of the shovel must be positioned above or in front of the accumulation to be flattened, at the desired height.

Press the switch (**ref. 5**) positioned on the right dashboard to activate the arms fluctuation valve.

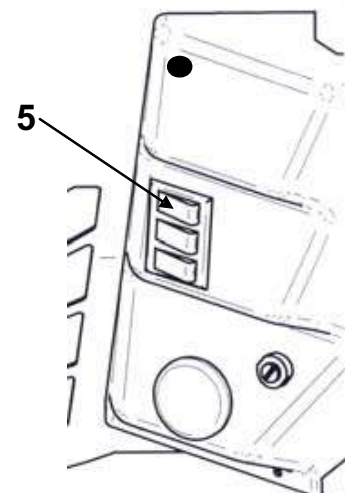

This switch MUST only be used with the ARMS ON THE GROUND. Activation with the arms raised consents to the immediate fall of the entire arm-bucket unit, with very serious risks.

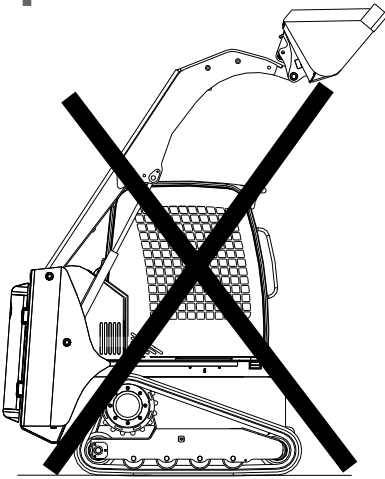

**RANGER OF SHEARING
RANGER OF CRUSHING
FATAL INJURIES**



Proceed in reverse gear and the bucket will follow the profile of the ground spreading the previously accumulated material.

DIGGING AND FILLING IN

DIGGING

The machine is not an excavator therefore digging is only allowed on loose ground, without stones and masses and which is generally easy to penetrate with the shovel.

To start digging turn the shovel downward until it slightly touches the ground after which advance slowly continuing to turn the shovel downwards until it penetrates the ground.

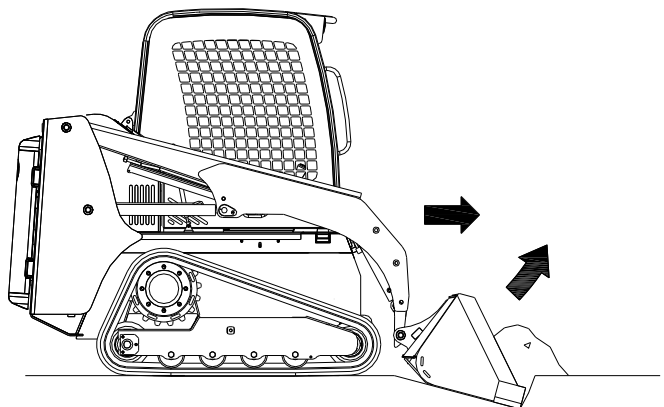

Advance, turning the shovel slightly backwards until it is filled.

When the shovel has been filled, turn it backwards to contain all of the shovelled material, lift it slightly and pull back to take it to the unloading area.

FILLING IN

Go to the area to be filled in at a moderate speed with the bucket turned downwards so that its base makes an angle of about 45° with the ground.

In proximity of the area to be filled in, slightly raise the lifting arms and turn the shovel completely forward to unload all of the previously accumulated material.

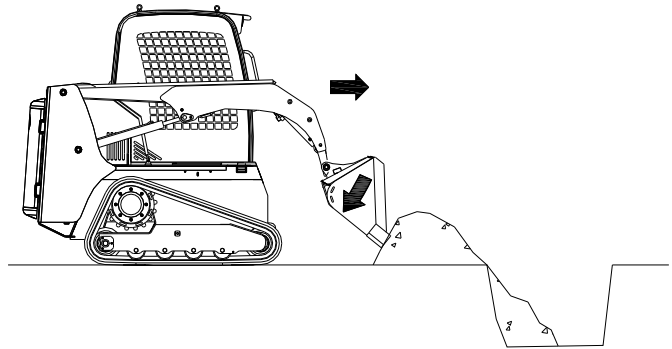

Pull back and repeat the operation until the ground has been levelled.



Regarding loading capacity of the shovel, refer to the data supplied in the TECHNICAL FEATURES AND DATA chapter. Do not overload the shovel.

An excessive load could cause loss of control or overturning of the machine with serious risks for the operator.

LIMITS FOR QUICK COUPLING UTILISATION AND RELATED EQUIPMENT, BUCKET INCLUDED.



With the lifting arms in maximum collection position, and in contact with the frame, **it is strictly prohibited to rotate the bucket completely towards the ground** as the pivot of the quick coupling of the bucket and the bucket itself, when the rotation of the track rollers is tampered with, can cause damage to same. Here below certain positions that should never be assumed are demonstrated with diagrams.

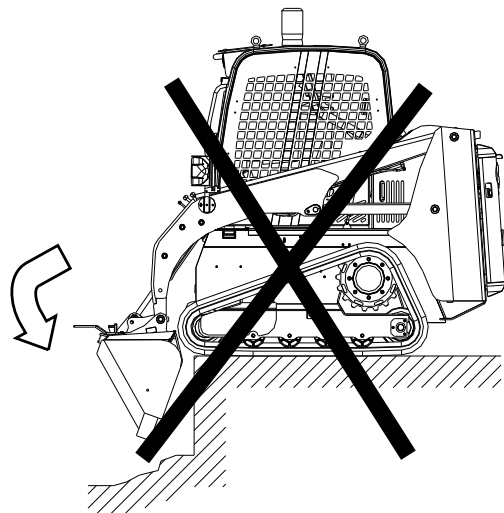
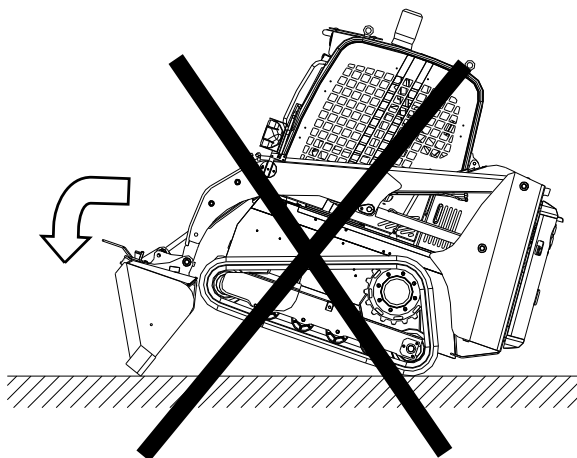

The maximum permitted rotation (to be executed with great care) is to that point where the quick coupling is level, parallel to the ground. In this position correct utilisation of the quick coupling is ensured.

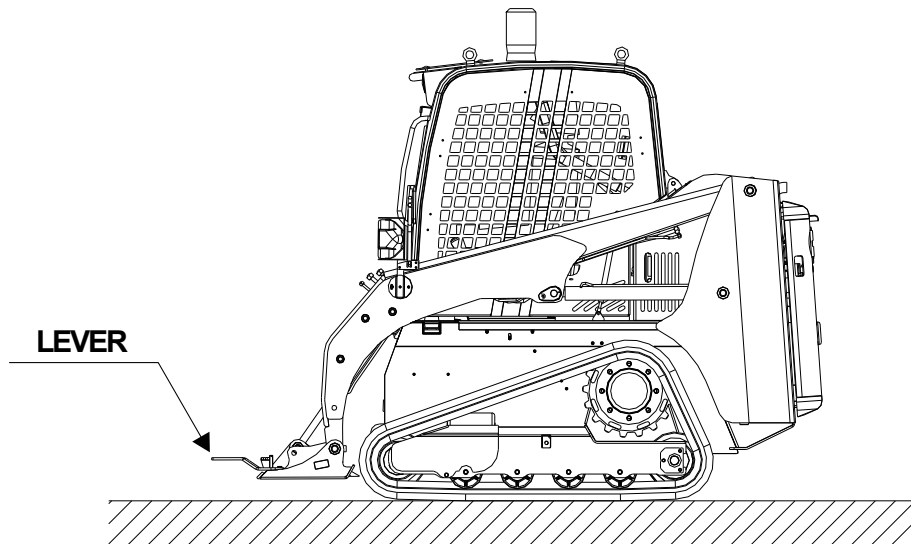

The lever of the quick coupling, without any other equipment, bucket included, must always be in the completely open position (pivot retracted).

Inobservance of the aforementioned guidelines could result in premature damage to the track rollers.

TOWING THE MACHINE



THIS MACHINE MAY NOT BE TOWED

For removal purposes, in case of **EMERGENCY**, only utilise lifting apparatus.



EQUIPMENT

AND

ACCESSORIES



SHOVEL REPLACEMENT OR REPLACEMENT OF OTHER ACCESSORIES PREPARED FOR QUICK FITTING

SHOVEL ASSEMBLY

1 – Go to the shovel lying on the ground as shown in the diagram, turn the quick fit device forward and turn the attachment lever to the outside.

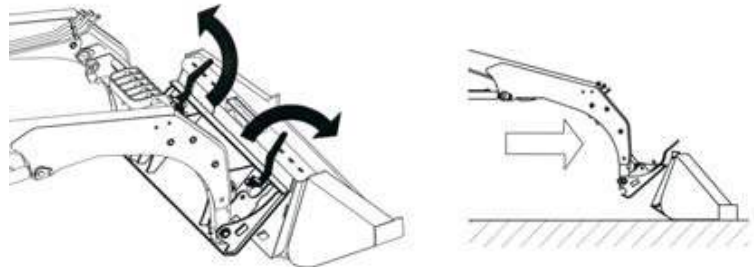

2 – When the shovel has been attached raise the lifting arms so that the shovel moves away from the ground and turn the attachment device backwards allowing the shovel to rest on its base.

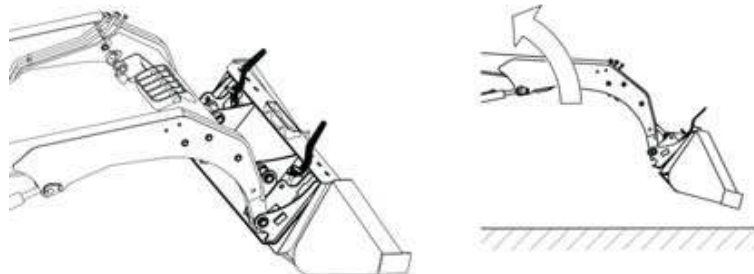

3 – Turn the levers inwards to block the shovel on the attachment base.

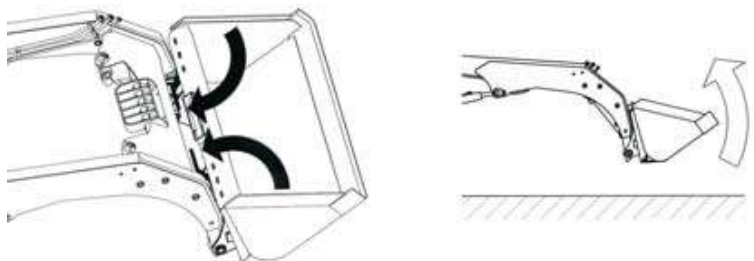

SHOVEL RELEASE

To release the shovel proceed as follows:

- 1 - Rest the shovel on the ground
- 2 - Open the attachment lever
- 3 - Turn the quick fit device forward until the shovel is released from it's seat and then remove the shovel.

The mounting and disassembling procedure is to be repeated with any type of equipment authorised by the Manufacturer with the exclusion of special equipment whose mounting and disassembling procedure will be delivered with the accessory.

HYDRAULIC POWER TAKEOFF (PTO)

The quick couplings are positioned in the internal part of the left lifting arm and have the following features:

Plane face quick couplings:	3/8"
Work pressure:	180 bar
Pump capacity:	39 l/min.



RANGER OF SCALDING



Pay particular care during the quick engagement connection and release operations as the high oil temperature could heat the points excessively and therefore render grip difficult.

Clean the male and female coupling areas well before connection checking that there are no grooves or scratches that can jeopardise holding.

CONNECTION: The connection is obtained by pulling back the brace positioned at the end of the female coupling and inserting the male coupling into it

RELEASE: Release is obtained by pulling back the female coupling brace and pulling out the male coupling.

DRIVING CABIN

The standard machine is equipped with an open cabin, which, on request, can be completed with a front lockable door, windscreen wipers and a heating system with n.2 orientable vents for the emission of hot air inside the cabin. These vents are located under the seat support

The cabin is certified against tipping (**ROPS**) and against falling objects (FOPS 1st level). On request, for particular conditions of use, **FOPS 2nd level** protection can be supplied.

Level 1: protection against small falling objects, for example small rocks, small debris and other small objects that can be found in maintenance operations on roads and motorways, parks and gardens or when building other service areas.

Level 2: protection against large falling objects, for example large rocks, large debris and other large objects that can be found in operations such as building and demolition.

HEATING PLANT

Use the switch to control the two-speed fan in machines equipped with the heating system (ref. 13). While for functioning of the plant open tap "R" positioned above the diesel engine, corresponding to the alternator.

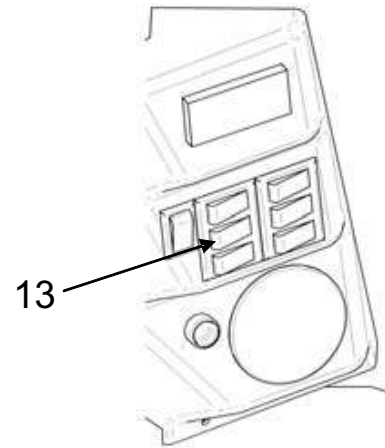

POSITION A: CLOSED
POSITION B: OPEN

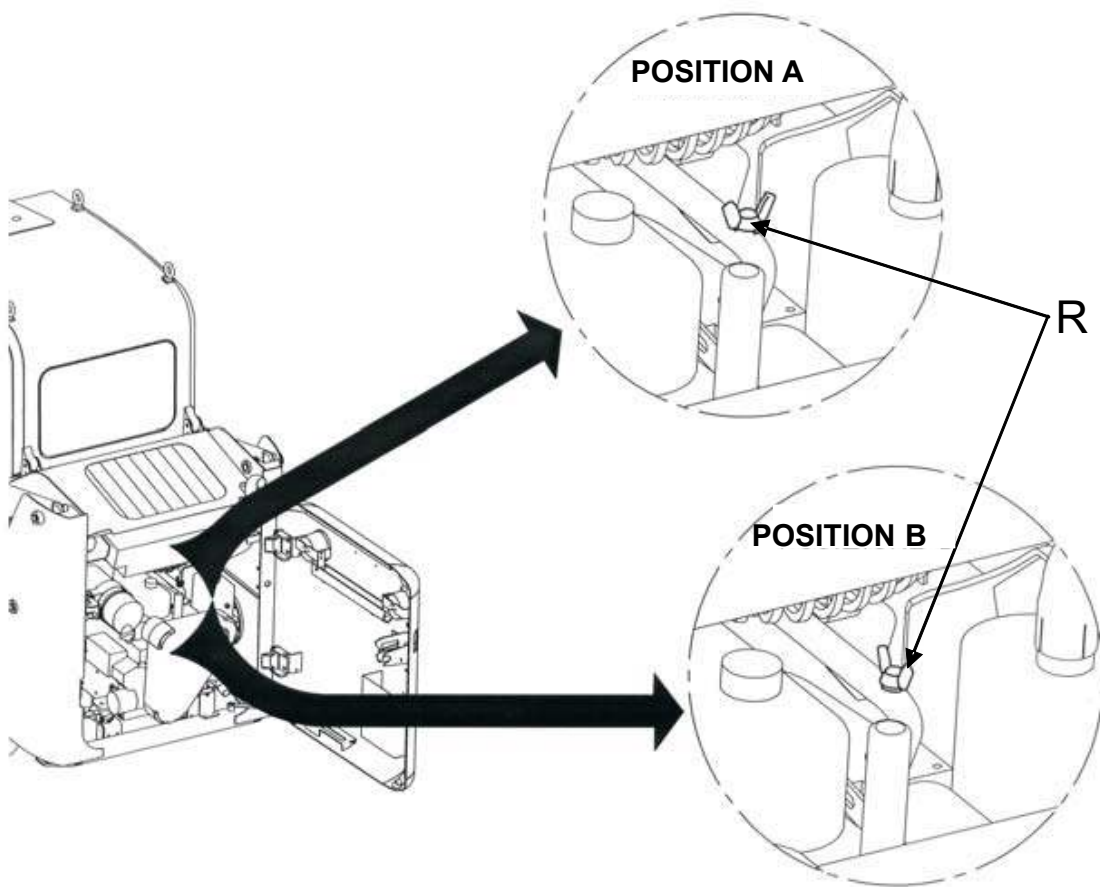

The cabin and driver's position are adequate for use in normal climates; **it is prohibited** to use the machine with polar clothing.

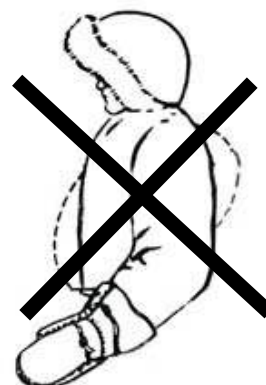

USE OF LIFTING FORKS

The forks must **always and only** be used with the **self-levelling** valve installed.



It is prohibited to exceed the indicated nominal capacity. Non-compliance of capacities consented by the Manufacturer causes the loss of stability of the machine or even overturning.

ONLY USE FORKS AUTHORISED BY THE MANUFACTURER

The maximum capacities corresponding to the centre of gravity of the load are stated below.

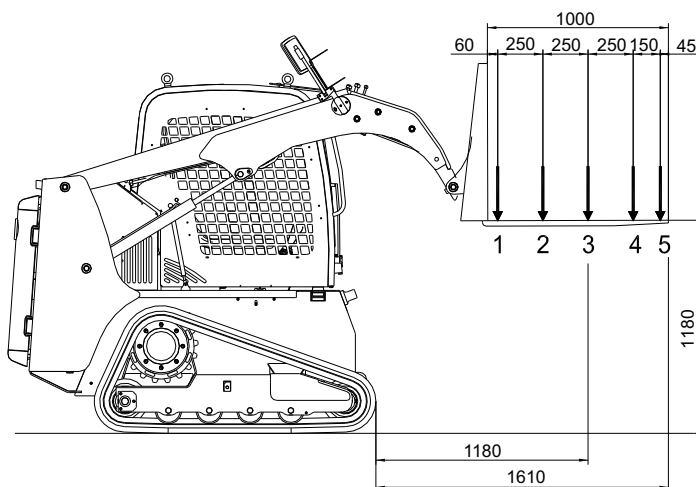

Position 1: Capacity Kg 325

Position 2: Capacity Kg 260

Position 3: Capacity Kg 210

Position 4: Capacity Kg 180

Position 5: Capacity Kg 125



Particular caution must be carried out when the forks are used to unload material withdrawn in a high position and deposited in a low position.

Before proceeding with unloading, as well as checking the compatibility of the load with the maximum load admitted, it is necessary to alternate, in tracts, descent with a backward rotation of the forks (at least 4÷5 times) to maintain the load in a horizontal position or slightly orientated towards the cabin.



Always block the forks to the fork-support plate and the latter to the machine's quick fitting in a way that the forks are always centred with the machine's longitudinal axle.



The movement must be carried out with the load as low as possible; at very low speed and on flat, compact ground. Lift the load. If necessary, only in the immediate vicinity of the place of deposit.



Distance the forks adequately on the basis of the load to be lifted. The load must always be positioned at the centre of the forks with the centre of gravity centred on themselves to always have max. stability during movement. Never use the forks individually but in a couple as supplied.



It is prohibited to lift and transport persons or live animals.



Do not pass or stop underneath a raised load.
Never pass the load above people.



Do not operate if there is not sufficient visibility or the minimum safety requirements for the work to be carried out are not present.



Never leave the machine with the engine running and the load raised from the ground.



Control wear and pressure of the tracks as any failure could unbalance the load with its loss or worse, overturn the machine.

SUPPLIES AND EQUIPMENT

STANDARD EQUIPMENT:

- ROPS and FOPS 1st level open cabin
- Power take off (PTO) with quick fitting with electric control for use of optionals.
- Floating valve to adjust the shovel to the ground
- Quick fit for bucket
- Front working lights
- Reverse gear alarm

OPTIONAL EQUIPMENT:

- Cabin door
- Lateral window
- Heating plant
- 2nd level FOPS
- Self-levelling valve for parallel lifting of shovel and forks
- Lighting plant for road circulation
- Anti-piercing, anti-blow-out tyres
- Snow chains
- Various forks
- Hydraulic hammer
- Bucket sweeper
- Hydraulic boring machine
- Blade grass-cutter
- Snowplough



ATTENTION

It is prohibited to use accessories **not supplied** by the machine's manufacturer. Modified or unauthorised equipment could be the cause of damage to the machine or fatal injury to the operator.



ORDINARY

MAINTENANCE



PRELIMINARY INFORMATION



The maintenance operations must be done exclusively by a qualified personnel.

To facilitate the control, the machine is equipped with an hour counter placed on the dashboard, which registers the functioning time and work.

Only with perfect maintenance can the machine be maintained in perfect condition allowing to work well and in safety.



Always ensure, before working on the machine, that all the appropriate precautions have been taken to guarantee that the person(s) carrying out the maintenance, repair, etc. may work in total safety.

All cleaning operations must be carried out with the engine cold using, where possible, a jet of pressurised water. Do not use solvents or similar substances to prevent damaging the guards, gaskets, etc., and the paintwork.

Do not dispose of the oil and other liquids leaked during the maintenance operation in the environment. Collect it and send it to an authorised waste disposal.

It is advisable to equip an area dedicated to maintenance operations, protecting it from dripping deriving from any drawing of hydraulic tubes, connections, joints.

All inspection and checking operations of the hydraulic system must be carried out with the oil at operating temperature (**around 60° C**).

LUBRICATION AND GREASING

MAINTENANCE SAFETY

When for maintenance requirements or other, it is necessary to raise the cabin, it must always be blocked using the special supplied base level moving it from Position 1 to Position 2.

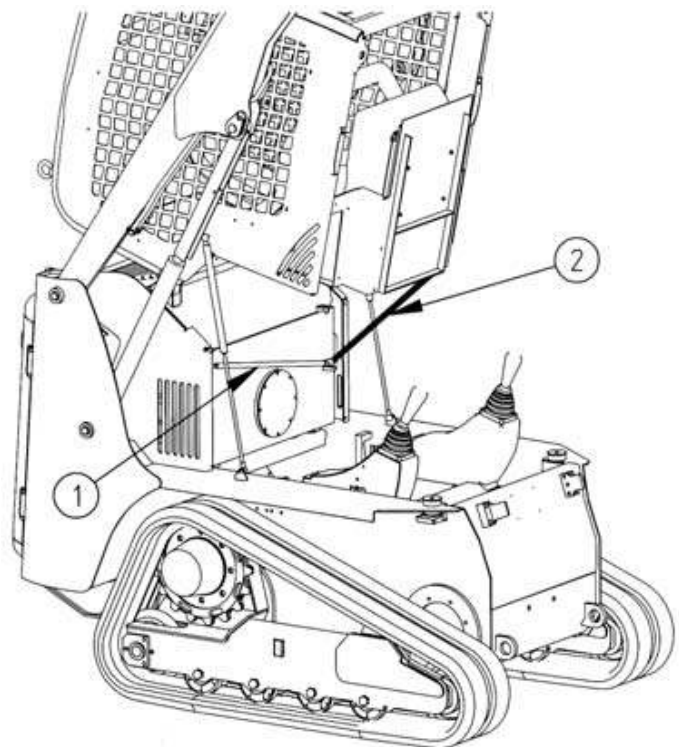

Analogue safety system (**ref. 3**), fixed inside of the engine hood, which must be installed every time the shovel lifting arms are raised to prevent uncontrolled descent.

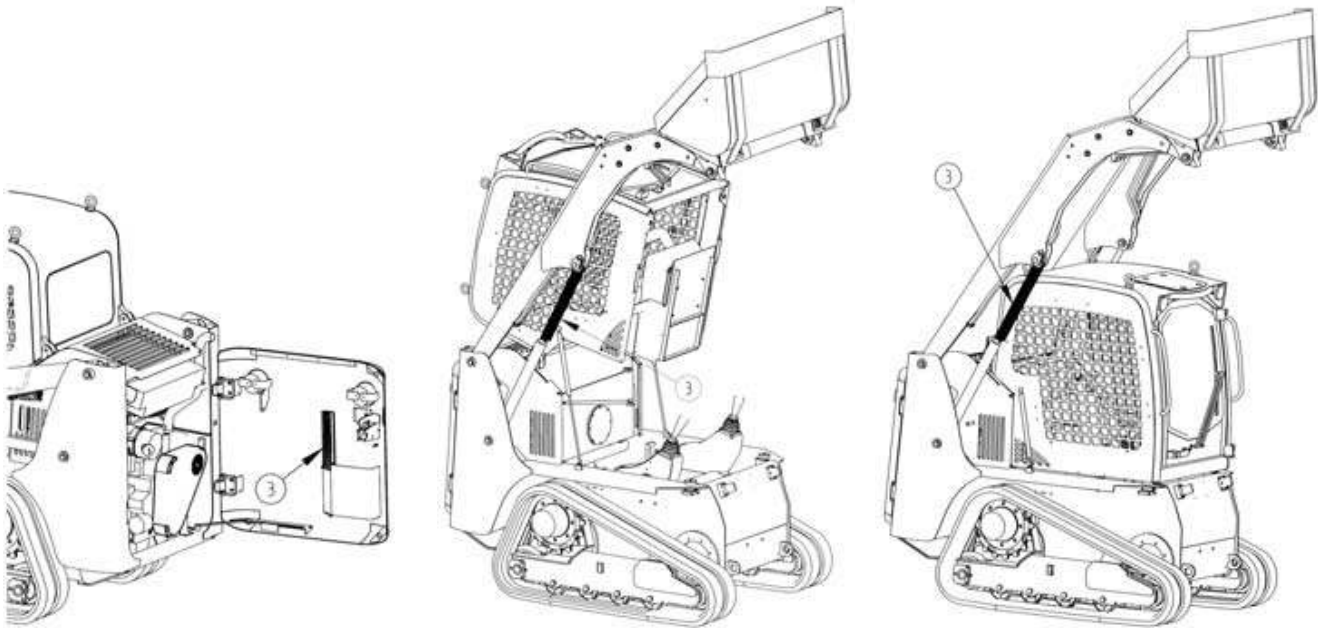

The engine hood is supplied with a lever “A” that allows shutdown and blocking in a completely open position.

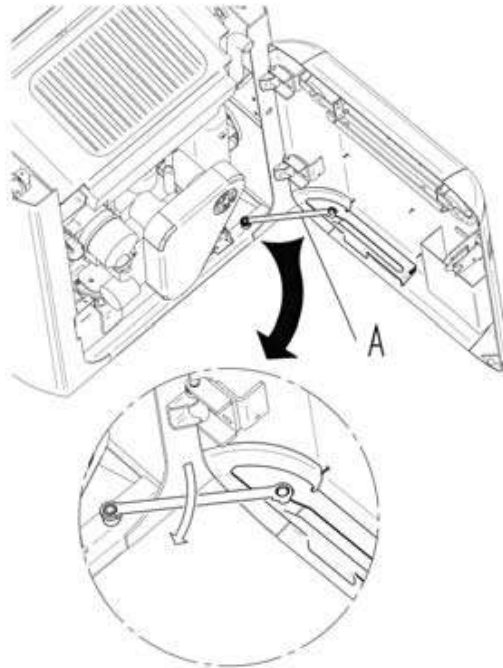

For closure, turn lever “A”.



DANGER OF SHEARING

Never place any part of the body between the fixed part and the open hood as sudden closure could cause serious injury or mutilation.

IMPORTANT:

Regarding **USE AND MAINTENANCE** of the diesel engine and components connected to it **ALWAYS COMPLY** to that stated in the Manufacturer’s Use and Maintenance booklet for the engine installed on the machine.

The **RE-FUELLING TABLE** states the quantity of liquids, lubricant and supplies for the necessities of all individual machine parts.

The oils and lubricants used to supply the machine on delivery are **AGIP PETROLI**; do not top-up with oils or liquids that are different from those recommended. Complete replacement is advised. Recommended products can be replaced by other brands as long as they have the same features.

Regarding the diesel engine supplies always refer to the attached Manufacturer’s User and Maintenance Booklet.

GREASE POINTS

In the scheme beside are indicated the principal greasing points: they must be supplied every 8 hours except for those with a different indication.

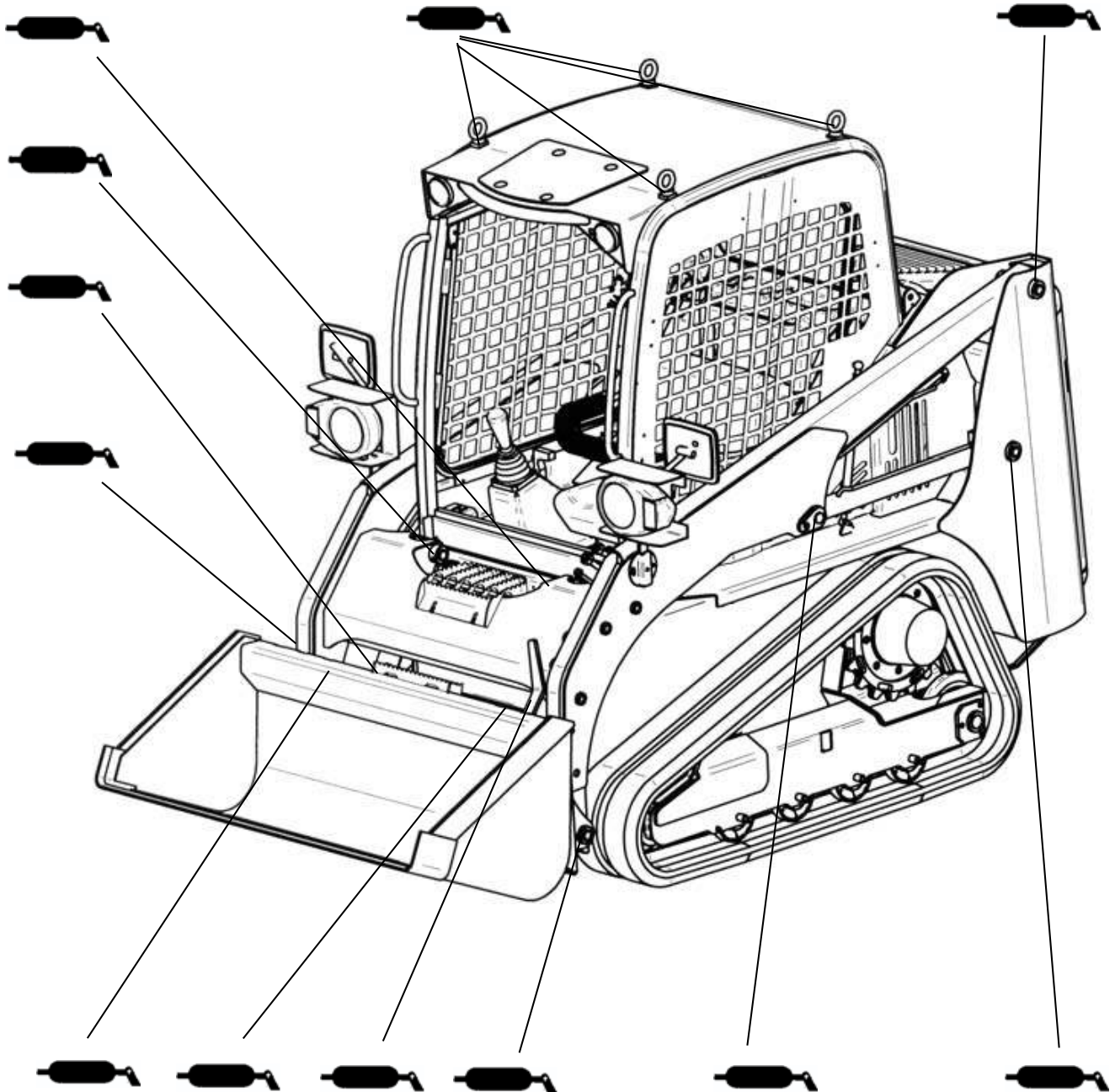

Note: the track supporting rollers are of the permanently lubricated type, therefore they do not need to be periodically greased.

STOPPING AND RESTARTING AFTER INACTIVITY

MACHINE STOPPING DUE TO INACTIVITY

When anticipating a long period of machine inactivity, it is recommended to place it under cover in a dry place.

Below follows some advice and precautions to take before shutting down the machine.

- Thoroughly clean and wash the machine with pressurised water and dry it, especially in the zones not protected by paint or without special protections. Touch up any chips or scratches to prevent harmful oxidation.

- Completely empty out the fuel tank and fill it with about 10 litres of diesel fuel with added oil, and then drain the system. Start the engine and let it run for about 10-15 minutes to ensure uniform distribution of the lubricant. When the operation has been completed and before switching off the engine, lower the machine arms, laying the bucket on the ground and inserting a piece of wood. Then again fill the fuel tank with diesel fuel.

- Completely change the oil of the diesel engine, hydraulic system and wheel reduction gears, taking care to replace the various filters.

- Dismantle the battery, checking the level, top up with distilled water if necessary and store it in a dry and protected place.
Periodically check the level during inactivity.

- Lubricate all the grease points, rods, articulated joints and those delicate parts requiring special care and protection.

RESTARTING AFTER INACTIVITY

To restart the machine after inactivity follow the instructions listed and recommended below:

- Remount the battery, checking the level and charge.

- Check the levels of the engine oil, hydraulic system and wheel reduction gears.

- Start the engine and leave it to idle for about 10-15 minutes. On completion, check perfect functioning of the various mechanical and electrical parts and the hydraulic controls.

SPECIAL CONDITIONS OF USE**Muddy, humid, snowy terrain:**

- Check hermetic seal of the caps and valves.
- Clean and check the machine overall, tightness of the nuts and screws, and check for any sagging due to knocks or formation of cracks, etc.

Marine terrain:

- Check hermetic seal of the caps and valves.
- Generally clean the machine and wash with sweet water to remove deposited salt which causes corrosion and rust.
- Check and inspect functioning of the electrical system to prevent corrosion and various faults.

Dusty terrain:

- Periodically check and clean the air filter.
- Check and clean the terminal board of the alternator and the starter.
- Clean the water/oil radiator

Rocky terrain:

- Use the machine with caution, carry out manoeuvres and movements gently to prevent damaging of the tires or the rubber tracks.
- If possible, use reinforced buckets.
- Before starting the operating phases, check the articulations, joints, pins and fastening of the various elements of the machine and of the bucket.

Icy terrain:

- Use a fuel suitable for low temperatures or use specific additives.
- Use lubricants suitable for use at low temperatures, both for the hydraulic system and the engine system.
- Use antifreeze in the water radiator.
- Periodically check the battery level.
- Protect the tires against possible compacting with earth during extended parking or stopping.

REFILLING, INSPECTIONS AND CHECKS

A - Pressurised filling cap (0.7 bar) to restore the level of engine cooling liquid.

B - Engine cooling liquid level indicator.

C - Radiator filling cap (supply complete).

D - Hydraulic oil introduction cap. (38 spanner).

E - Fuel introduction cap

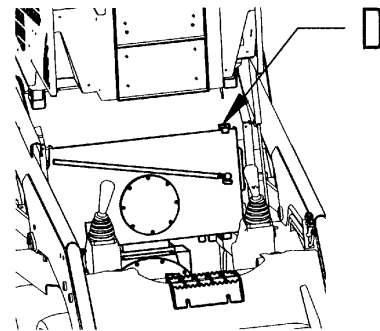
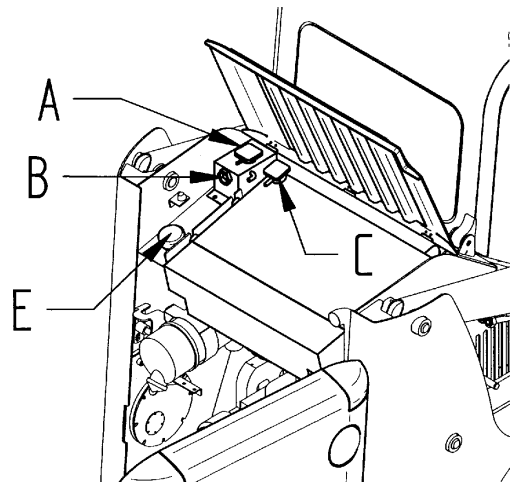

FUEL SUPPLY SYSTEM

The fuel tanks are situated on the rear left and right sides of the machine; their lower parts are connected with a lower pipe. The fuel introduction cap “E” is on the left tank and is accessible by opening the engine hood.

A special indicator (**Fig.1 - ref. 1**) on the dashboard signals when it goes into reserve.

Avoid emptying the tank completely, since due to the air entering the system, the diesel engine would fail to start once refilled if the circuit is not drained beforehand.

When filling the tank with fuel, use a funnel fitted with a very fine metallic mesh filter to avoid problems with the injection system due to solid impurities which may be present in the fuel.

Concerning the addition of additives for use at the different temperatures, in particular in cold climates, follow the instructions in the use and maintenance manual of the engine manufacturer, supplied with the machine.

- Total tank capacity | 42

SUPPLYING, VERIFICATIONS, DIESEL MOTOR COOLING SYSTEM CONTROLS:

- The radiator is situated in the rear part of the machine, above the diesel engine.
- For capacity and filling refer to the RE-FUELLING TABLES



- A special warning light (**Fig.1 - ref. 7**), on the left dashboard, signals the inefficiency of the diesel engine cooling circuit. Checking and top-up of the level of liquid must be carried when the engine is cold. If the cap of the expansion tank “A” of the cooling liquid positioned at the side of the radiator is still hot use a protective glove or rags soaked in cold water.

- Never place the face over the cap when opening.



**DANGER OF BURNS
DANGER OF SCALDING**

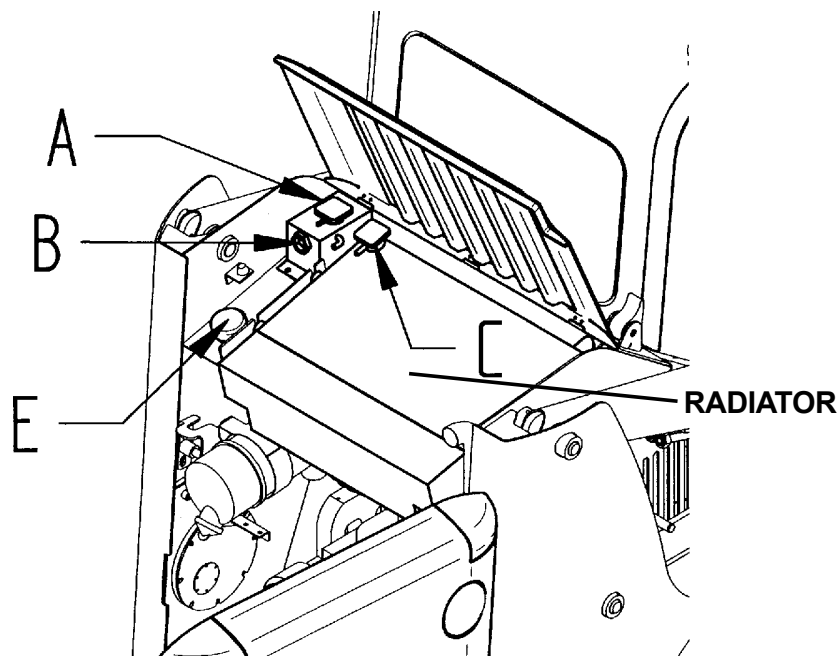

The engine cooling liquid is maintained at a service temperature using a fan positioned beneath the radiator and is activated by a hydraulic engine.

If it doesn't function or functioning is anomalous check the pressure of engine connection “1” of the fan.

The pressure detected must be 100 bar.
If this is not detected, contact CUSTOMER SERVICE

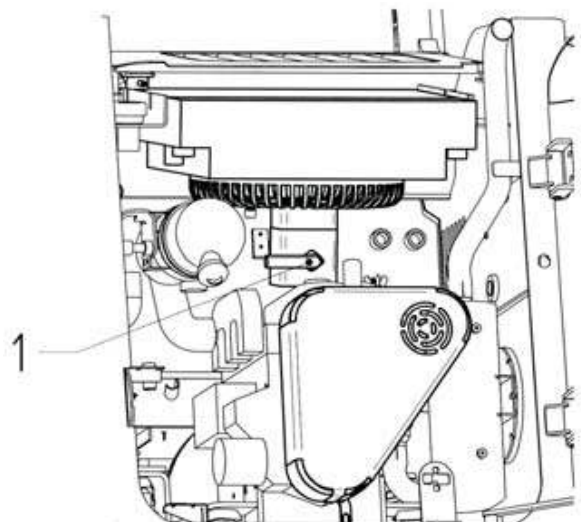

DIESEL ENGINE LUBRICATION SYSTEM



Concerning use, refilling, engine oil and coolant check, starting and stopping, air filter inspection and cleaning, and everything to do with maintenance, follow the instructions in the USE AND MAINTENANCE manual of the engine manufacturer, supplied with the machine.

The instructions in this manual were taken from the use and maintenance manual of the engine manufacturer and used to simplify the topics discussed, in order to give a more complete and immediate view.

To introduce oil use supplied funnel "2".

To drain off used oil use the relative discharge pipe "3" prepared on the engine and orientated in a way to discharge through the opening in the floor of the frame into a container with adequate capacity.

Never dispose of used oil in the environment; it must always be disposed of through Authorised Companies.

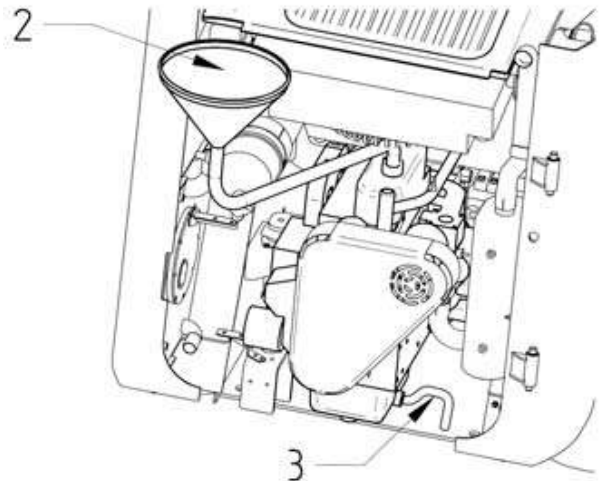

ENGINE AIR SUCTION PLANT

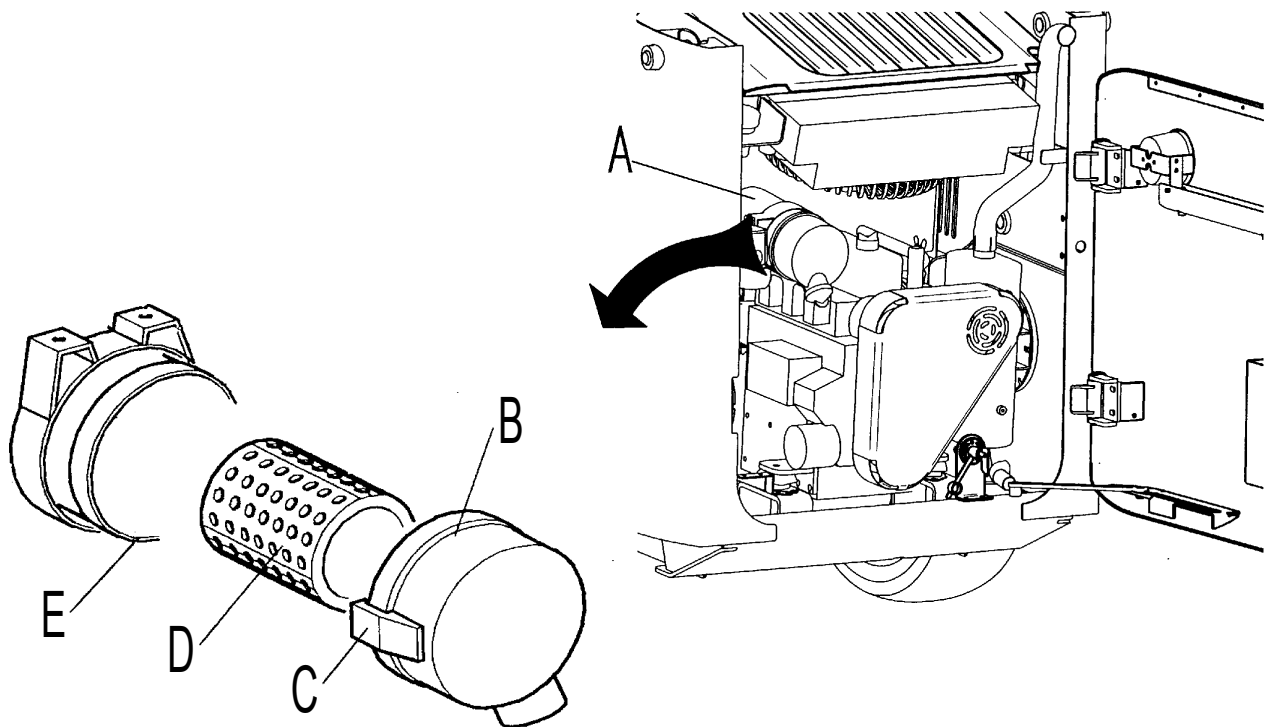

- The air filter "A" is positioned in the rear part of the machine.
- A special luminous warning light, situated on the left dashboard panel signals filter inefficiency, see Fig. 1 (ref. 7 - 7.7).
- To check efficiency or replace cartridge "D" proceed as follows:
 - 1 - Shutdown the DIESEL engine.
 - 2 - Release handles "C" from the filter body "E" and remove cover "B".

- 3 - Turn cartridge “D” alternately forwards and backwards pulling it towards the back to release it from its seat.
- 4 - Clean cartridge “D” by blowing dry air at a pressure not higher than 3 bar from the inside towards the outside at a distance of 3/4 cm from the walls.
- 5 - Also clean the body “E” and cover “B”.
- 6 - Complete the operation and check suitability and efficiency of the cartridge. Re-mount it positioning it in its seat exerting light pressure to position it in stroke.
- 7 - Re-attach cover “B” to the filter body “E” using handles “C”.

ATTENTION

It is however recommended to replace the cartridge every 6/8 months, according to the work environment.

DRIVE TRANSMISSION

Every tracks is activated by a hydrostatic motor-reducer.
 For oil checks, filling, replacement in the wheel reducers refer to that specified below.



Periodically check (see MAINTENANCE TABLE) that there are no leaks and that with the machine at a standstill and the reducers positioned as indicated below, the oil reaches the envisioned level; restore if necessary.

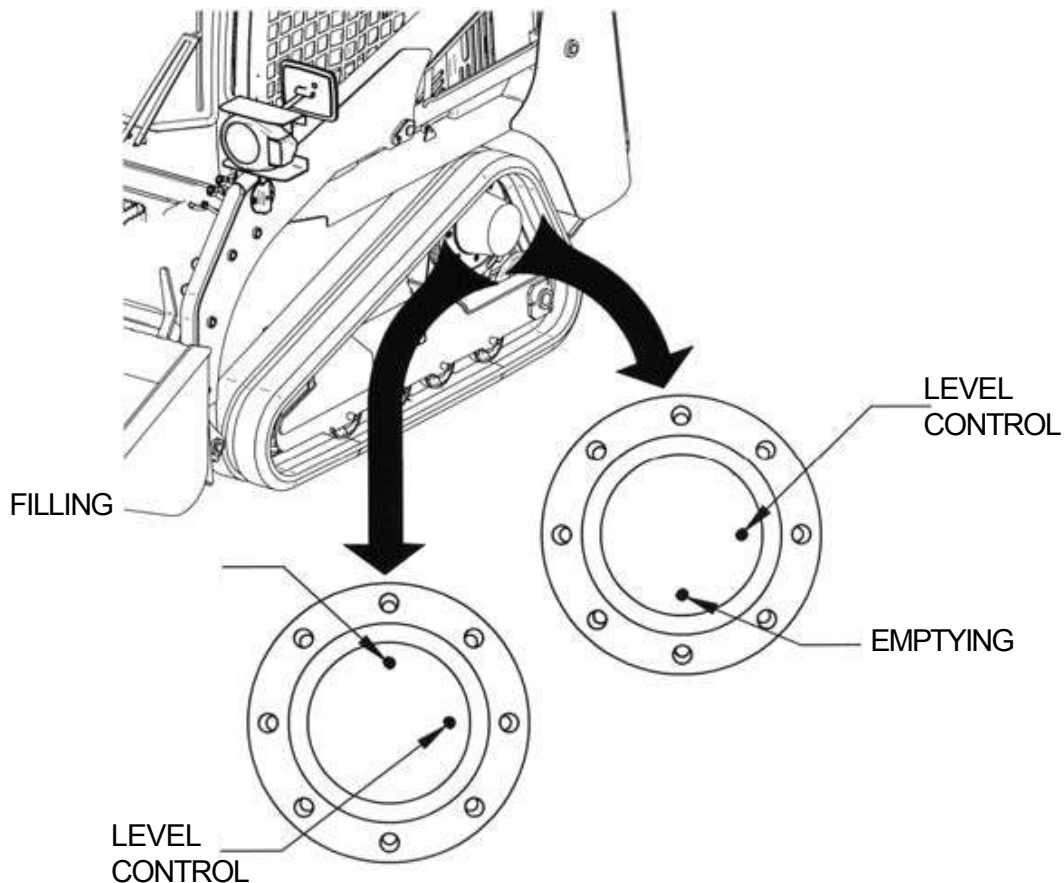

A top-up higher than 10% of the quantitative total could be a sign of leakage of the reducer.



The first oil change must be carried out after 100 hours of functioning. The following changes after 1000 hours or at least once a year. Per capacity and type, refer to the LUBRICANT TABLE.

The reducer must be emptied immediately after functioning, with the oil still hot to prevent impurities from depositing.



- Pay particular attention during emptying as the hot oil could cause serious burns; protect the hands.
- Clean the cap with liquid detergent especially during the filling phase. Cleanliness is an important component for the good functioning of the machine and the hydrostatic plant in particular.



- If the decrease in oil level inside the reducer is detected, in absence of external leaks, the seals inside the reducer must be checked at an **Authorised Assistance Centre**.



- Level checks and restoration, filling and emptying must be carried out with the machine level and horizontal and the engine at a standstill.
- Insert a container under the unload tap which is big enough to collect the oil. The entire operation can be made easier by dismantling the tyre after having fixed the machine opportunely.

SERVICE, EMERGENCY AND PARKING BRAKE DEVICE

(TRASMITAL-BONFIGLIOLI GEARED MOTOR)

- A** - HYDRAULIC POWER ATTACHMENT
- B** - OIL CHAMBER PRESSING IN RELEASING PHASE
- C** - BRAKE DISKS
- D** - BRAKE CORE
- E** - BRAKING PISTON PRESSURE SPRING
- F** - TRANSMISSION DISENGAGING SCREW FOR TOWING

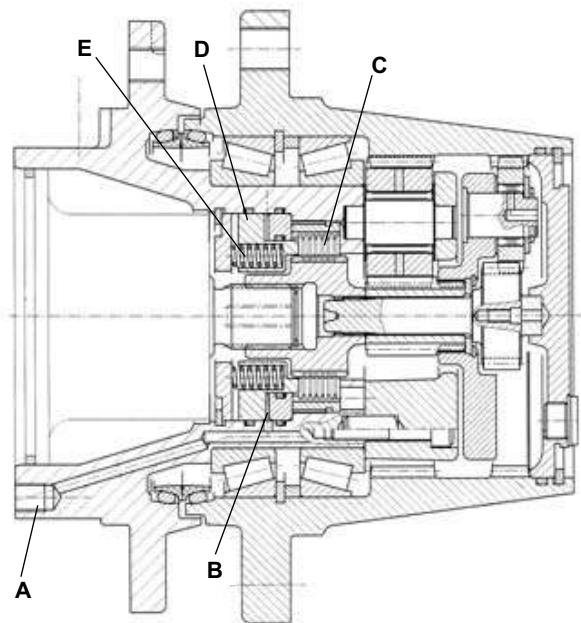

SERVICE, EMERGENCY AND PARKING BRAKE DEVICE

(BREVINI GEARED MOTOR)

- A** - HYDRAULIC POWER ATTACHMENT
- B** - OIL CHAMBER PRESSING IN RELEASING PHASE
- C** - BRAKE DISKS
- D** - BRAKE CORE
- E** - BRAKING PISTON PRESSURE SPRING
- F** - TRANSMISSION DISENGAGING SCREW FOR TOWING

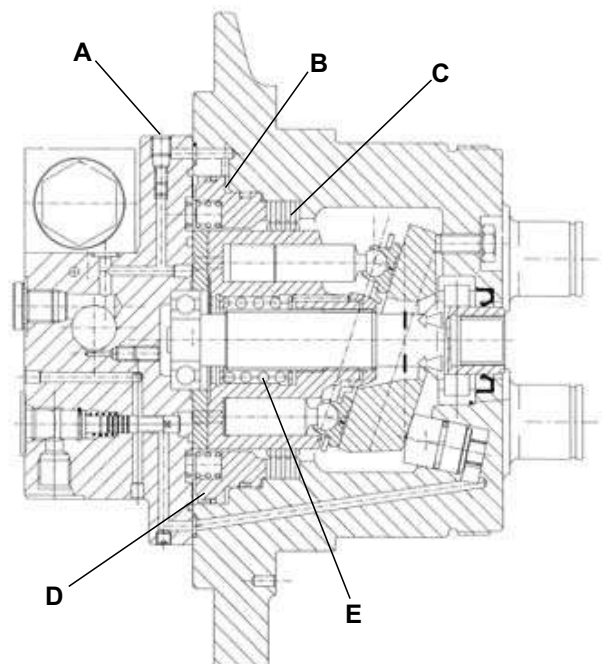

DESCRIPTION OF FUNCTIONING:

- Unblock the brake by activation of the left Joy-stick.
- With the Joy-stick in neutral position the brake is always inserted.

- Activation of the left Joy-stick allows the hydraulic oil to pass through attachment “**A**” into chamber “**B**” causing the braking piston to move away “**D**” and consequently the unblocking of brake disks “**C**”.

- With the left joy-stick in the neutral position no oil passes and therefore there is no movement of the braking piston “**D**” and the brake disks “**C**”, remaining in contact pushed by the force of the springs “**E**”, allow the machine to shutdown and/or stop.

TRACK TENSION CONTROLS AND ADJUSTMENT

On the external sides of the track support, an opening is placed inside which a valve, greased, is positioned to adjust the tension of the track.

The exact tension of both tracks is essential for the good functioning of the machine, both in driving and working phases.

A tension too low or too high means an incorrect functioning of the machine with sliding risks, or even worse, serious damaging of the same tracks or parts of its transmission: gear, trailer wheel, support rollers, bearings, pegs, etc. From what said, the importance of a correct track tension seems evident, which can be obtained and maintained following the indications and practical suggestions supplied below.

The interval of the controls is summed up in the maintenance table; however, the controls of the new track should be carried out daily.

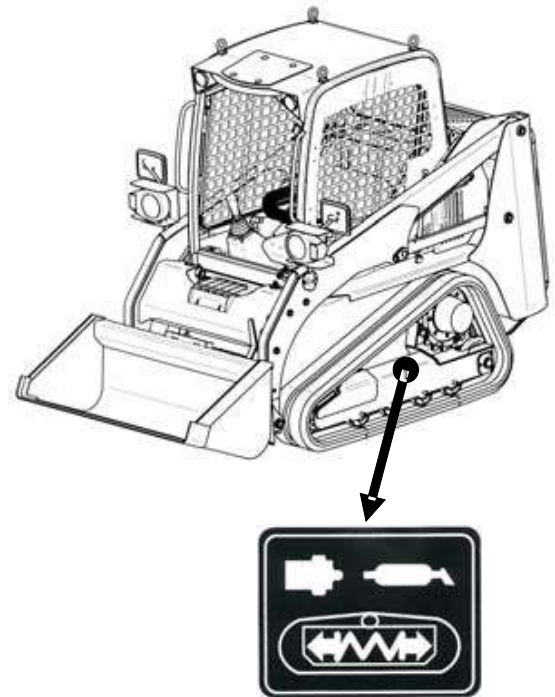

Move to a flat area, on hard and compact ground, open digger and lower it until the front part of the machine is completely lifted; only the extremity of the digger and the rear trailer wheel of the track must remain in contact with the ground.

For the correct tensioning, verify that the internal lower part of the track perfectly adheres to all 4 support rollers. If not, restore the correct tension by acting as illustrated below.

To restore the suggested value, pump grease on to the adjusting valve using the appropriate head on the machine. Stop when adjustment is completed. Before proceeding, inspection of the track and various transmission organs is suggested, removing dirt and debris eventually deposited between the track and the driving wheel, trailer wheel and support rollers in that they might alter the tension adjustment.

Pay particular attention during the head connecting phase, in that the grease contained in the track tension cylinder and blocked by the valve, may be violently expelled with the connected risks.

The valve may be removed only by the Assistance Service personnel.

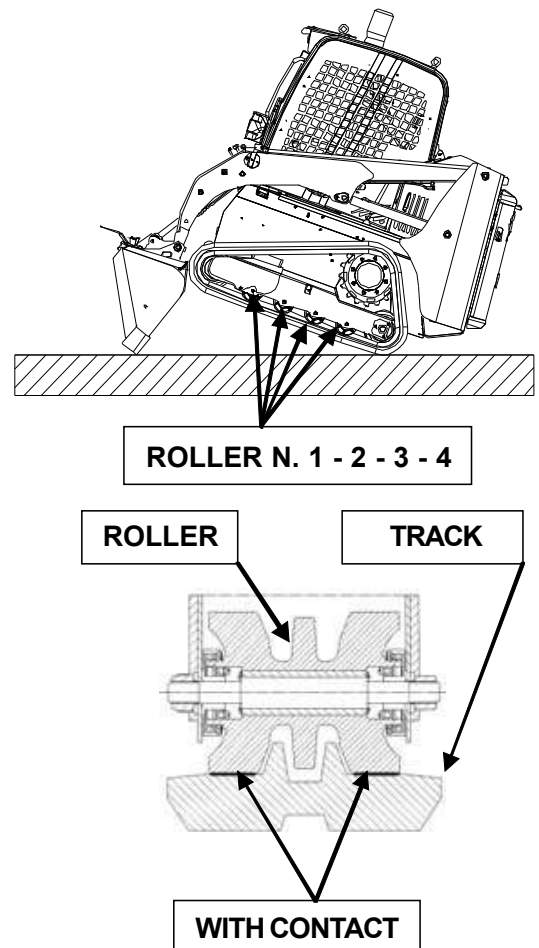

In the event that one or both tracks need further adjustment after the machine has been restarted, repeat the operations described previously, starting from machine lifting and taking the required precautions.

- Re-insert the head on the valve and begin to pump oil within the device until correct track roller tension is achieved.
- It is advisable to make the track turn idling, giving it the possibility to stop, if it is the case pump more grease, always using the provided pump and the head.

USE OF THE MACHINE

In order to safeguard the integrity and functionality of the track, follow the recommendations and specifications below:



- Avoid sudden steering and changes of direction when driving on road, in particular on hard and rough terrain full of sharp and cutting edges, with a high degree of friction.

DO NOT COUNTERSTEER: To turn left or right, both when driving or standing, operate only one track.

- During driving avoid the tracks coming into contact with sharp and cutting parts or overhangs.
- Avoid the tracks coming into contact with oils, solvents, fuel or other corrosive materials. Should this occur, immediately clean and wash the tracks.
- Avoid extended use of the machine on marine terrain or saline environment, since these conditions further detachment of the metallic core of the rubber.
- Due to the basic characteristics of the rubber of which the track is made, use at temperatures between -25° and +55° C is recommended.
- Avoid exposing the tracks to bad weather for extended periods. Sudden climatic variations further premature ageing.
- Possible wear of the crawler wheels may cause abrasions or detachment of the metallic core of the tracks. Ensure timely replacement.

FAULTS AND MALFUNCTIONING

A - BREAKAGE OF THE TRACK STEEL CORDS

- Excessive track tension combined with stones and loose materials which accumulate between the track and the underbody.
- Detachment of the track from the wheel guides.
- Strong friction in case of successive and rapid changes of direction.

B - WEAR OR BREAKAGE OF THE METALLIC CORES

- Excessive track tension.
- Improper contact between crawler wheel and track (*crawler wheel worn, debris between crawler wheel and track, etc.*).
- Use on sandy terrain.

C - DETACHMENT OF METALLIC CORE FROM THE RUBBER

- Excessive abrasion of the internal lateral parts of the track against the guide rollers (*excessive and sudden steering and countersteering*).
- Spiking of worn crawler wheel during rotation.



WARNING

These faults imply immediate replacement of the damaged track

D - ABRASIONS OR TEARS DUE TO FATIGUE OR EXTERNAL FACTORS:

- Generally, these faults are caused by both the way the machine is used and the nature of the place of operation.

These track alterations may be reduced, but not eliminated, by prudent and responsible use of the machine, and do not require immediate replacement of the track, even if it has almost come to the end of its life and it is time to replace it.

Replacement is also recommended in case the “tread” is down to about 2-5 mm.

- The abrasions, tears, cuts on the external surface of the track (*that in contact with the ground*) are in most cases due to contact with sharp stones or cutting materials (*plating, glass, nails, tile chips*) which cause cuts and complete or partial shredding of parts of the track. It is evident that due to the properties of the rubber this is inevitable, even if it depends on the specific use and on the service conditions.

NB: The integrity of the rubber track and its faster or slower wear mainly depend on how it is used and the way the machine is operated.

CHECKING TIGHTNESS OF NUTS AND BOLTS

METRIC THREAD	DRIVING TORQUE (daNm = Kgm)
	Class 8.8
M6	1÷1.2
M8	2.3÷3.0
M10	4.5÷5.3
M12	7.8÷9.0
M14	13÷14
M16	20÷21



Periodically check tightness of the main parts of the machine:

- Drive transmission
- Engine fixing supports
- Quick fitting
- Operator cabin
- Arms and shovel caster retainer

N.B.: The resistance class of the nuts and bolts not specifically indicated is 8.8
To facilitate the fastening operations, the table on the side lists the driving torques according to the relevant dimension and class of resistance.

HYDRAULIC SYSTEM

The oil tank is situated in the rear central part of the machine, with the filling cap “D” positioned in the rear left side and accessible with the cabin raised. The visual level indicator “A” is situated on the tank’s left lateral wall. This is used to control the level of liquid container. For the capacity and filling up follow the chapter “REFILLING”.

- The oil level is checked with the machine standing level and with the cylinder rods at their maximum extension. In these conditions the oil level should not be below the minimum mark.
- The engine must be off.
- The oil must be at operating temperature (around 60°C).
- For top-ups unscrew the cap and use a funnel in order to introduce the oil, and this should be carried out very slowly.
- **The capacity of the tank alone at max. level is 30 litres.**

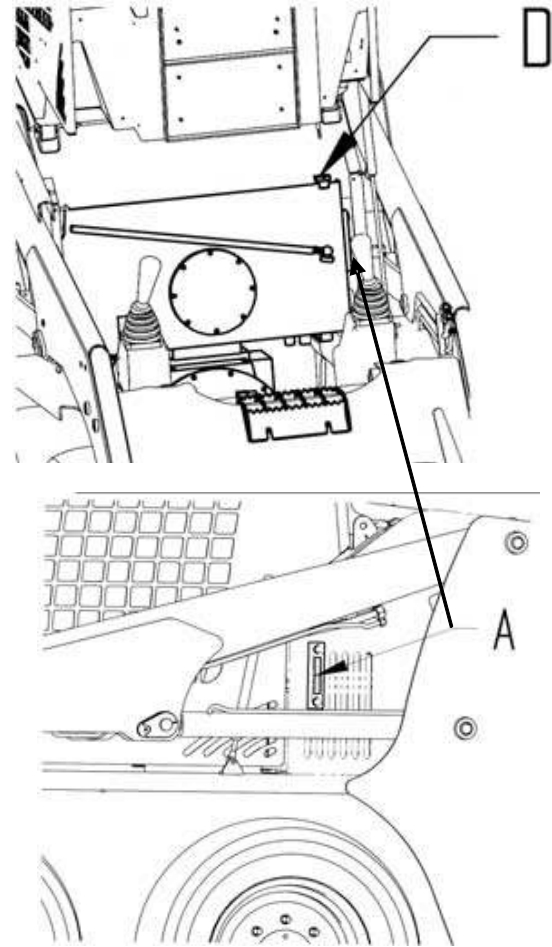

EXHAUST FILTER REPLACING:

- Positioned on the right internal side of the frame and accessible with the cabin raised.
- Replace the filter cartridge “FS” with another cartridge having the same features. The filter must be replaced for the first time after 100 hours of working. For successive replacements refer to the MAINTENANCE TABLE.

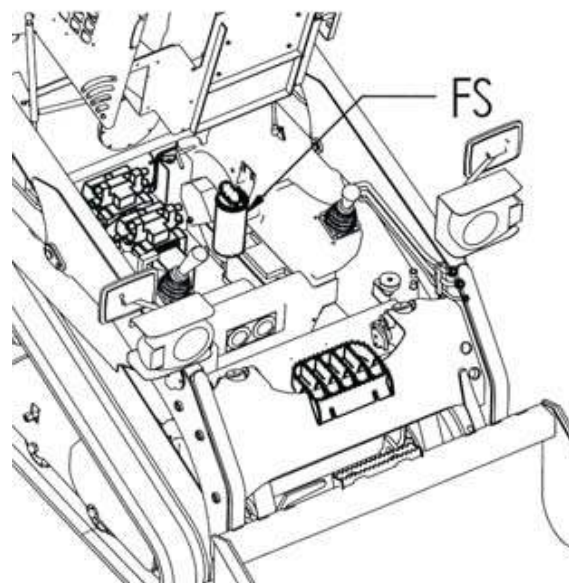

HYDRAULIC SYSTEM PRESSIONS CALIBRATION

Every skid steer loader or part of it is scrupulously controlled and inspected so as to supply the client with a perfectly efficient and functional plant from a mechanical, electrical and hydraulic point of view.

To make the inspection of the hydraulic system as easy as possible, the machine is equipped with **M16 x 2** quick-coupling fittings on which the pressure calibration values of the single mechanisms may be checked.

The attachment for detection of pressures for **traversing** are positioned on the left side of the transmission pump, visible with the cabin raised; **points 1, 2, 3, 4.**

- POINT 1:** - FORWARD movement left track
- POINT 2:** - REVERSE movement left track
- POINT 3:** - FORWARD movement right track
- POINT 4:** - REVERSE movement right track

The attachment for detection of plant service pressures, **point 5**, must be positioned at the end of the flanged connection on the pump.

The attachment for detection of feed pressures of servo-controls, **point 6**, is positioned on the rear left side of the transmission pump.



The pressions verification and control must be done by a specialized personnel and if it is possible in a Authorized Shop

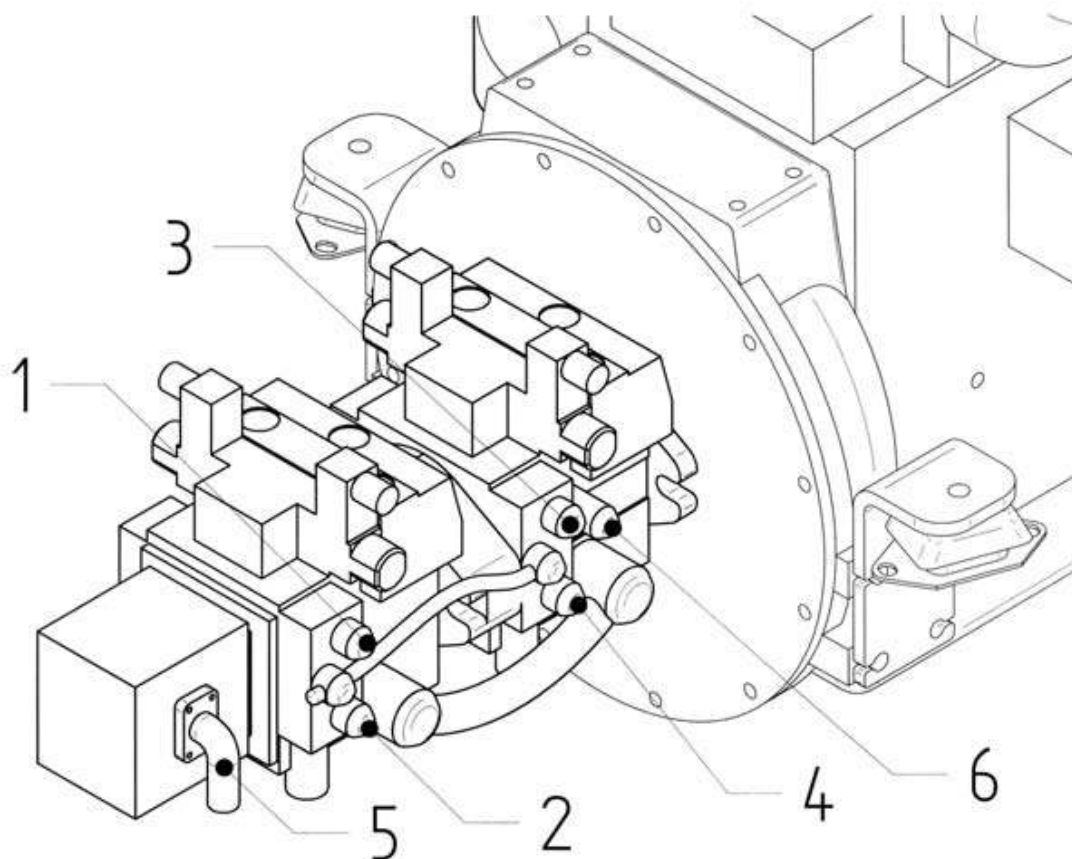

MECHANISMS PRESSURE

- **TRAVERSING:** (for every detection point **1; 2; 3; 4**) **300 bar**
- **SERVICES:** detection point **5** (arms and bucket) **180 bar**
- **SERVO-CONTROLS:** detection point **6** (joy-stick) **24 bar**

Do not arbitrary modify the valves calibration values, because they could be the reason of malfunctionings or damages, which could compromise the machine safety.

ELECTRICAL SYSTEM

The machine is equipped with a battery housed in the compartment under the seat. It is visible when the cabin is raised and has the following features:

VOLTAGE **12 V**
ABSORPTION **80 Ah**

If it will be necessary a battery substitution, the new battery will have the same characteristics of the ones indicated.

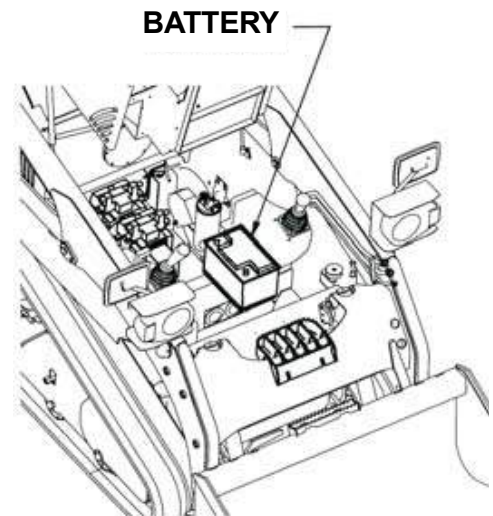

- For the level refer to the indications on the battery wrapping.
- For inspections and top-ups follow the instructions in the specific "MAINTENANCE" chapter.



- **Use exclusively distilled water for any top-ups**, do not use acid. The electrolyte could flow out due to gassing and cause serious burns.
- Always ensure perfect closure of the filler plugs.
- Do not completely discharge the battery.



- In case of fast discharge, check the voltage regulator. In the negative case, recharge the battery or replace it. The liquid contained in the battery is highly corrosive. Protect the eyes and hands during the inspection and top-up phase.
- Maintain the cable terminals well fastened and protected with grease, or even better, pure Vaseline.

Before disconnecting the battery disconnect the battery-detachment switch positioned in the engine compartment.



When disconnecting the battery, the earth wire (-) must be disconnected first.
When connecting the battery, the positive wire (+) must be connected first.

Keep tools and metallic objects away from the battery poles, since these could cause a short-circuit of the terminals with serious danger.



DANGER OF BURNS
DANGER OF SCALDING

In case of stops for a long period at low temperatures, it is recommended to protect the battery or store it in a hot and sheltered place.

**⚠ REMOVE THE PROTECTION BEFORE START-UP;
DANGER OF FIRE.**

The machine is fitted with a switch located in the engine compartment, which allows disconnecting the battery for any EMERGENCY, and in case of extended stops (*more than 4 hours*). Always contact authorised workshops for battery recharging.

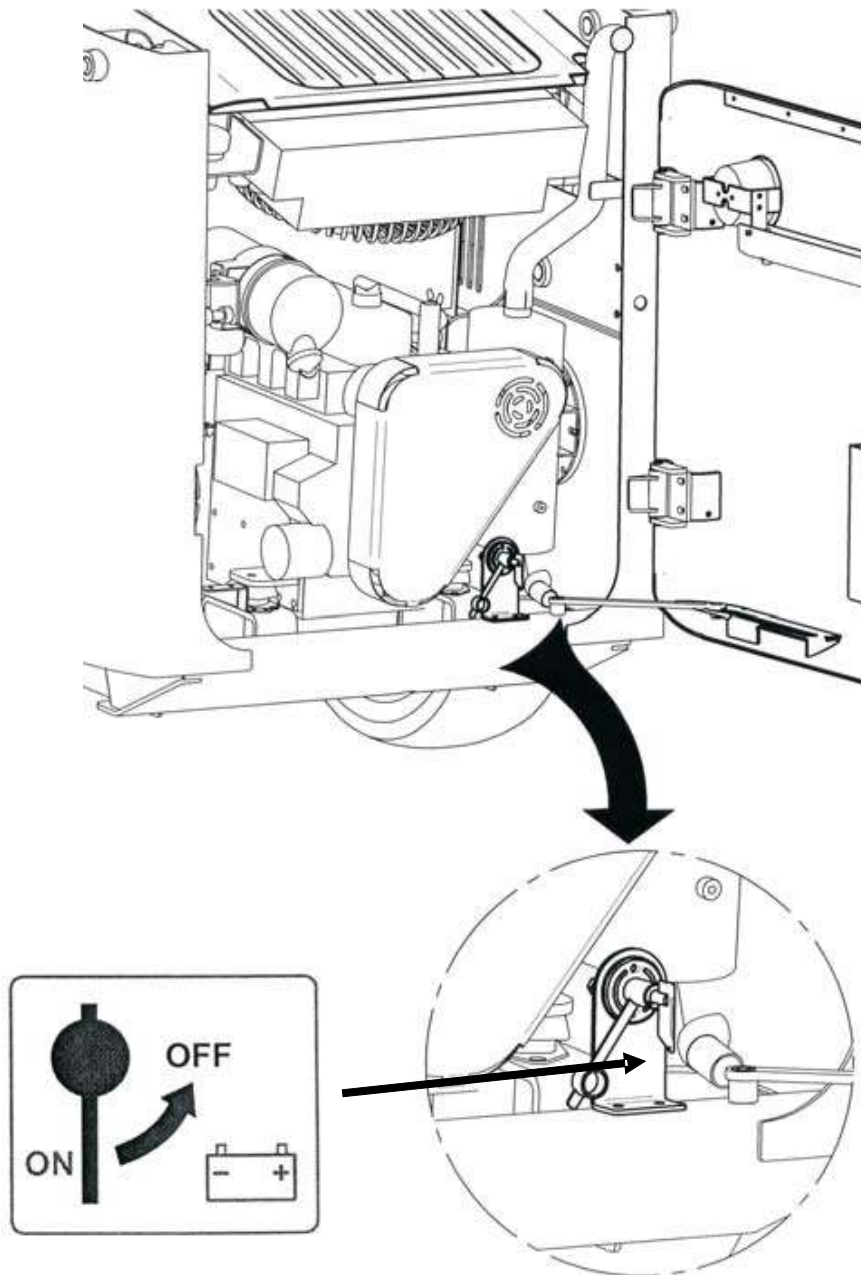

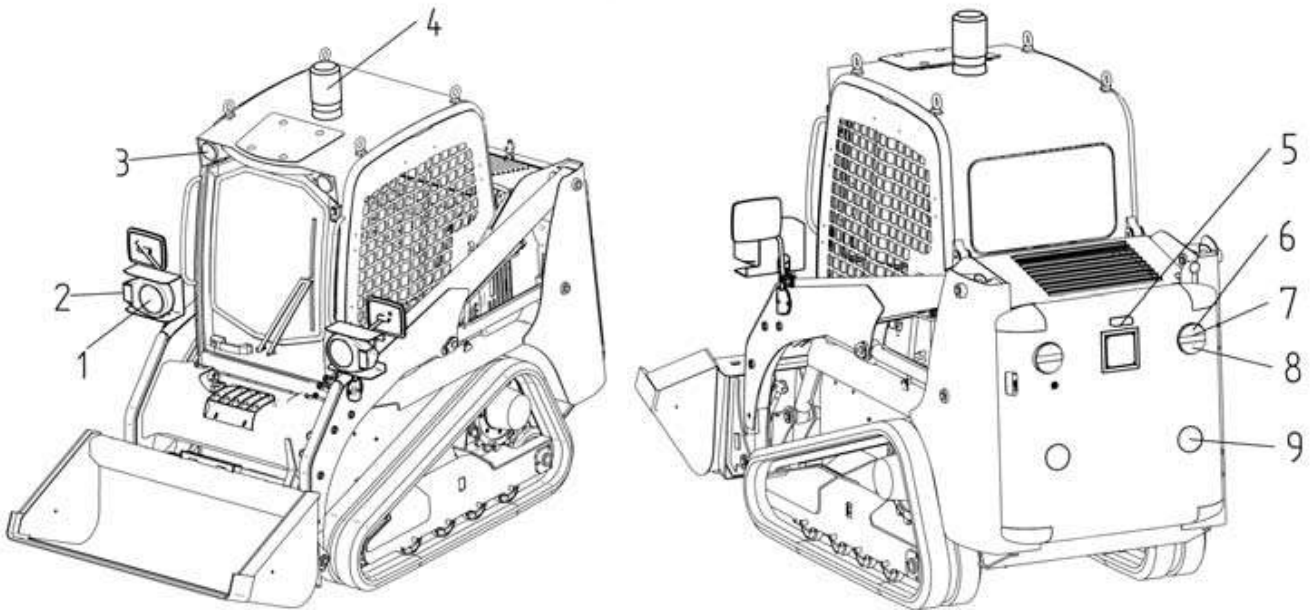
POSITIONING OF LIGHTS

- 1 - DIPPED-BEAM HEADLIGHTS
BULB: 12 V 60/55 W base H4
- 2 - ANTEROLATERAL DIRECTION INDICATORS
BULB: 12 V 21 W base BA 15S
- 3 - WORKING LIGHTS
BULB: 12 V 50 W base GE 886
- 4 - FLASHING LIGHT
BULB: 12 V 55 W base H1
- 5 - NUMBER PLATE LIGHT
BULB: 12 V 5 W base SV 8.5-8
- 6 - REAR DIRECTION INDICATORS
BULB: 12 V 21 W base BA 15S
- 7 - REAR STOP LIGHTS
BULB: 12 V 21 W base BA 15S
- 8 - REAR POSITION LIGHTS
BULB: 12 V 4 W base BA 9S
- 9 - REAR REFLECTORS

SUPPLY TABLE

PART	FUEL: BRAND and TYPE	Q.ty
FUEL TANK	DIESEL FUEL	42 lt
HYDROSTATIC AND HYDRAULIC SYSTEM	OIL AGIPARNICA 46	30 lt
TRAVERSING MOTOR REDUCERS	AGIP ROTRA MP 80W90 OIL	0,7 lt cad.
DIESEL ENGINE	AGIP SIGMA S SAE 30 OIL	6,0 Kg
ENGINE RADIATOR	AGIPANTIFREEZE COOLING LIQUID	9,0 lt
ARTICULATIONS, PINS AND BUSH- INGS, FIFTH WHEEL	GREASE AGIP GR SM	S.E.

The table below lists the quantity of liquids, lubricants, refilling required for the single parts of the machine.

The oils and lubricants used for refilling of the machine at the time of delivery are from AGIP PETROL. Do not top up with oils or liquids different from those recommended. It is advisable to carry out a complete oil change.

The products recommended may be substituted for other brands on the condition that they have the same characteristics.

MAINTENANCE TABLE



OPERATION TO PERFORM	COMPONENT CONCERNED	FREQUENCY IN HOURS					
		8	50	100	200	400	1000
CLEANING	AIR FILTER - CARTRIDGE		•				
	RADIATOR - FINNING		•				
	SILENCER AND SHOVEL	•					
	GAS OIL FILTER CUP			•			
	DIESEL FUEL TANK						•
	HYDRAULIC OIL TANK						•
CHECKING AND CORRECTING, IF NECESSARY	MOTOR CUP OIL LEVEL	•					
	COOLANT LEVEL	•					
	BATTERY LEVEL		•				
	HYDRAULIC OIL LEVEL	•					
	AIR FILTER (Stoppage spy)	•					
	WHEEL REDUCTION GEAR OIL LEVEL				•		
	TRACK ROLLER TENSION	**	•				
	ALTERNATOR BELT				•		
	FIFTH WHEEL			•			
	PINS AND ARTICULATED JOINTS	•					
ELECTRICAL AND HYDRAULIC CIRCUIT	•						
REPLACEMENT	MOTOR CUP OIL				•		
	ENGINE OIL FILTER CARTRIDGE				•		
	DIESEL FUEL FILTER CARTRIDGE					•	
	GAS OIL PRE-FILTER					•	
	HYDRAULIC OIL						•
	COOLANT					•	
	HYDRAULIC OIL FILTER (CARTRIDGE)					•	
	ALTERNATOR BELT					•	
	WHEEL REDUCTION GEAR OIL AND			*			•
	AIR FILTER CARTRIDGE					•	
GREASING	GREASE POINTS	•					
PARTIAL OVERHAUL		EVERY 2000 HOURS (4 YEARS)					
TOTAL OVERHAUL		EVERY 5000 HOURS (10 YEARS)					

* FIRST CHANGE

** During the first week of track roller utilisation, controls must be carried out every 8 hours.

FAULTS: CAUSES AND REMEDIES

ENGINE		
FAULT	CAUSE	REMEDY
START FAILURE	BATTERY DISCONNECTED	CONNECT
	BATTERY FLAT	RECHARGE, REPLACE
	BATTERY TERMINALS OXIDISED, DISCONNECTED OR LOOSE	CLEAN, CONNECT, TIGHTEN
	GLOW PLUG FUSE TRIPPED	REPLACE FUSE
	STARTING MOTOR INEFFICIENT	INSPECT AND REPLACE IF NECESSARY
	INJECTION PUMP, DIRTY, FAULTY INJECTORS	CLEAN OR REPLACE THE FAULTY COMPONENT
	WATER, IMPURITIES OR AIR IN FUEL SUPPLY SYSTEM	RELEASE AIR, DRAINING, CLEAN TANK
	INCORRECT ENGINE OIL	
	LACK OF FUEL	REPLACE, USE RECOMMENDED OIL
	FUEL FILTER CARTRIDGE BLOCKED	CHECK AND TOP UP
	FUEL SUPPLY PIPES DAMAGED	REPLACE
	SAFETY BAR LOWERED	INSPECT AND REPLACE IF NECESSARY
	RAISE	
EXCESS BLACK FUMES	AIR OUTLET CLOGGED	INSPECT, CLEANING OF FILTER CARTRIDGE AND REPLACE IF NECESSARY
	DIRTY OR FAULTY INJECTORS	REPLACE
	INJECTION PUMP INEFFICIENT	CALL AN AUTHORISED WORKSHOP
	IMPURITIES IN THE FUEL	FILTER OR CHANGE BRAND
	ENGINE COLD	WARM UP FOR ABOUT 10 MINUTES WITH ACCELERATOR AT HALF-TRAVEL
IRREGULAR FUNCTIONING <i>(follows)</i>	ENGINE OIL LEVEL LOW	CHECK AND TOP UP
	AIR OUTLETS OBSTRUCTED	INSPECT, CLEANING OF FILTER CARTRIDGE OR REPLACE IF NECESSARY
	FUEL FILTER DIRTY OR BLOCKED	REPLACE

FAULT	CAUSE	REMEDY
<i>(continues)</i> IRREGULAR FUNCTIONING	FAULTY INJECTORS	INSPECT, REPLACE
	ACCELERATOR BROKEN	INSPECT, REPAIR
	POOR COMPRESSION	CALL AN AUTHORISED WORKSHOP
	INSUFFICIENT POWER SUPPLY	CHECK PLANT POWER SUPPLY, REPLACE FUEL FILTER
ENGINE OVERHEATING  STOP IMMEDIATELY	ENGINE OIL LEVEL TOO LOW	TOP UP
	THERMOSTAT FAULTY	INSPECT, CALL AN AUTHORISED WORKSHOP
	RADIATOR BROKEN, FAULTY, CLOGGED	INSPECT, CLEAN OR REPLACE
	AIR FILTER CLOGGED	CLEAN, REPLACE
	COOLING FAN FAULTY, BROKEN	INSPECT, REPLACE
	MALFUNCTIONING OF WATER TEMPERA- TURE INDICATOR ON DASHBOARD OR BULB FAULTY	INSPECT AND IF NECESSARY, REPLACE THE COMPONENT CONCERNED CHECK, TOP UP
	RADIATOR COOLANT LEVEL LOW	INSPECT, REPLACE
	BREAKAGE OF WATER / ALTERNATOR PUMP	INSPECT, REPLACE INSPECT, REPLACE
	WATER PUMP BREAKAGE	
	BREAKAGE OF ENGINE COOLING FAN CONTROL PUMP	INSPECT, REPLACE
BREAKAGE OF ENGINE COOLING FAN		
PRESSURE LOW ENGINE OIL  STOP IMMEDIATELY	ENGINE OIL LEVEL TOO LOW	CHECK AND TOP UP
	PIPE AND CONNECTOR OIL LEAKS	CHECK, REPLACE OR TIGHTEN
	ENGINE OIL FILTER BLOCKED	REPLACE
	OIL LEAK	CHECK, LOOK FOR THE CAUSES, FILL UP
	INCORRECT ENGINE OIL	REPLACE, USE RECOMMENDED OIL
	OIL PRESSURE WARNING LIGHT OR BULB INEFFICIENT	INSPECT AND IF NECESSARY, REPLACE THE COMPONENT CONCERNED

FAULT	CAUSE	REMEDY
GENERATOR LIGHT ON	ALTERNATOR DOES NOT RECHARGE	CHECK BELT TENSION EFFICIENCY, REPLACE ALTERNATOR (CALL AN AUTHORISED WORKSHOP)
BATTERY DOES NOT RECHARGE	ELECTROLYTE LEVEL LOW	CHECK, TOP UP
	TERMINALS LOOSE OR OXIDISED	INSPECT, CLEAN, TIGHTEN
	ALTERNATOR BELT FAULTY	CHECK, RESTORE TENSION, REPLACE
THE STARTER TURNS VERY SLOWLY	STARTER FAULTY OR BROKEN	INSPECT, REPLACE
	BATTERY CLAMPS OXIDISED OR LOOSE	INSPECT, CLEAN, TIGHTEN
	BATTERY FLAT	CHECK LEVEL , REPLACE
	INCORRECT ENGINE OIL	REPLACE, USE RECOMMENDED OIL

HYDRAULIC SYSTEM

FAULT	CAUSE	REMEDY
HIGH HYDRAULIC OIL TEMPERATURE	UNSUITABLE HYDRAULIC OIL	USE RECOMMENDED OIL
	HYDRAULIC PIPES BLOCKED	CALL AN AUTHORISED WORKSHOP
	HYDRAULIC FILTER CLOGGED	REPLACE
	HYDRAULIC PUMPS DAMAGED	CHECK, CALL AN AUTHORISED WORKSHOP
	MAX. PRESSURE VALVES FAULTY, NOT CALIBRATED	CHECK, CALIBRATE AND REPLACE IF NEEDED
	HYDRAULIC OIL LEVEL LOW	
	FROTHY OIL DUE TO INFILTRATION OF AIR	INSPECT, RESTORE REMOVE THROUGH PUMP SUCTION
	HYDRAULIC OIL DIRTY	
	MANOEUVRES NOT CONFORM WITH MACHINE USE	CHECK AND REPLACE IF NECESSARY USE THE MACHINE LINEARLY WITHOUT FORCING THE CONTROLS. (IN PARTICULAR)
SLOW MOVEMENT OF HYDRAULICALLY CONTROLLED PARTS (insufficient performance) (follows)	HYDRAULIC OIL OVERHEATING	COOL FOR THE APPROPRIATE TIME

FAULT	CAUSE	REMEDY
(continues) SLOW MOVEMENT OF HYDRAULICALLY CONTROLLED PARTS (insufficient performance)	INCORRECT HYDRAULIC OIL	INSPECT, USE RECOMMENDED OIL
	HYDRAULIC PUMPS DAMAGED	CALL AN AUTHORISED WORKSHOP
	IRREGULAR FUNCTIONING OF HYDROSTATIC MOTORS	CALL AN AUTHORISED WORKSHOP
	CYLINDER SEALS WORN	INSPECT AND REPLACE IF NECESSARY
	VALVE DECALIBRATION	CHECK AND RESTORE CALIBRATION VALUES IF NECESSARY (CALL AN AUTHORISED WORKSHOP)
FOAMY HYDRAULIC OIL	AIR IN SUCTION SYSTEM	CHECK AND RELEASE IF NECESSARY
	WATER IN OIL	REPLACE OIL AND CLEAN TANK
	INCORRECT HYDRAULIC OIL	REPLACE, USE RECOMMENDED OIL
	OIL LEVEL TOO LOW	TOP UP
LOW OR NO PRESSURE IN THE PLANT	INCORRECT HYDRAULIC OIL	REPLACE, USE RECOMMENDED OIL
	HYDRAULIC OIL LEVEL LOW	CHECK AND RESTORE IF NECESSARY
	CYLINDER SEALS WORN	INSPECT AND REPLACE IF NECESSARY
	MAX. PRESSURE VALVES FAULTY	CHECK, CALIBRATE AND REPLACE IF NEEDED
SERVOCONTROLS NOT FUNCTIONING	HYDRAULIC PUMP FAULTY OR BROKEN	INSPECT AND REPLACE IF NECESSARY (CALL AN AUTHORISED WORKSHOP)
	HYDRAULIC OIL LEVEL LOW	CHECK AND RESTORE IF NECESSARY
	SAFETY BAR RAISED	LOWER IT
	MICRO FAULTY	INSPECT AND REPLACE IF NECESSARY
	PIPES AND CONNECTORS DAMAGED	INSPECT AND REPLACE IF NECESSARY
	DIESEL ENGINE ROTATION SPEED TOO LOW	ACCELERATE SLIGHTLY

FAULT	CAUSE	REMEDY
POOR EFFICIENCY SERVOCONTROLS	HYDRAULIC PUMP DAMAGED	INSPECT AND REPLACE IF NECESSARY (CALL AN AUTHORISED WORKSHOP)
	HYDRAULIC OIL LEVEL LOW	CHECK AND RESTORE IF NECESSARY
	HYDRAULIC SUCTION FILTER BLOCKED	INSPECT AND REPLACE IF NECESSARY
	PIPES, CONNECTORS FAULTY OR LOOSE	INSPECT AND REPLACE OR TIGHTEN IF NECESSARY
ONE OF THE SERVOCONTROLS DOES NOT FUNCTION	CURSOR DAMAGED	INSPECT, REPLACE
	PIPES , CONNECTORS FAULTY OR LOOSE	INSPECT AND REPLACE OR TIGHTEN IF NECESSARY
	PILOT VALVE DAMAGED	INSPECT AND REPLACE IF NECESSARY (CALL AN AUTHORISED WORKSHOP)
	PILOT PLANT PIPES AND CONNECTIONS DAMAGED	INSPECT AND REPLACE IF NECESSARY
ONE OF THE CYLINDERS DOES NOT FUNCTION OR FUNCTIONS SLOWLY	SEALS WORN OR DAMAGED	INSPECT AND REPLACE IF NECESSARY
	OIL LEAK	CHECK, RESTORE
	PIPES, CONNECTORS DAMAGED	INSPECT AND REPLACE THE COMPONENT CONCERNED IF NECESSARY
	DISTRIBUTOR VALVE DAMAGED	INSPECT AND REPLACE IF NECESSARY (CALL AN AUTHORISED WORKSHOP)
THE ARMS DO NOT REMAIN RAISED AND DESCEND SLOWLY	CYLINDER SEALS WORN OR DAMAGED	INSPECT AND REPLACE IF NECESSARY
	DISTRIBUTOR SPOOL INTERNAL THROTTLES	INSPECT AND REPLACE IF NECESSARY (CALL AN AUTHORISED WORKSHOP)
	DISTRIBUTOR VALVE DAMAGED	INSPECT AND REPLACE IF NECESSARY (CALL AN AUTHORISED WORKSHOP)

TRANSLATION REDUCTION GEARS DO NOT FUNCTION	PIPES, CONNECTIONS, FITTINGS DAMAGED	INSPECT AND REPLACE THE COMPO- NENT CONCERNED IF NECESSARY
	DAMAGED PUMPS	INSPECT AND CALL AN AUTHORISED WORKSHOP
	TRANSMISSION DISENGAGEMENT SCREW LOOSENED	CHECK AND EVENTUALLY TIGHTEN CORRECTLY
ONE REDUCTION GEAR DOES NOT FUNCTION	HYDRAULIC MOTOR DAMAGED	INSPECT AND REPLACE IF NECESSARY (CALL AN AUTHORISED WORKSHOP)
	FEED VALVE DAMAGED	INSPECT AND REPLACE IF NECESSARY (CALL AN AUTHORISED WORKSHOP)
	PIPES, CONNECTORS DAMAGED	INSPECT AND REPLACE THE COMPO- NENT CONCERNED IF NECESSARY
	TRANSMISSION DISENGAGEMENT SCREW LOOSENED	CHECK AND EVENTUALLY TIGHTEN CORRECTLY
VARIOUS SPEED OF THE TRACKS	PUMP FAULTY OR BROKEN	INSPECT (CALL AN AUTHORISED WORKSHOP)
	MOTOR REDUCER FAULTY OR BROKEN	INSPECT (CALL AN AUTHORISED WORKSHOP)



MAINTENANCE

NOTE



Edition: 12/2008