



GENERAL

SAFETY

REGULATIONS



SAFETY REGULATIONS FOR STARTING

The machine must only be driven by qualified staff that are at least 18 years old.
Before getting on, inspect the machine.

To enter or exit the cabin it is advisable to always turn towards the vehicle.

Use the steps and the handles. Do not jump and do not use the controls as supports.



Before starting the machine, check, adjust and lock the seat into position to ensure maximum driving comfort and ease of handling of the controls

It is recommended to hoot before starting to move and manoeuvre.

OPERATING SAFETY

Never operate the machine in closed environments, unless there is an efficient system for suction and discharge of flue gas.

Before using the machine, ascertain that all the safety devices are in place and in working order. Poor visibility may cause accidents. Keep the windows clean and use the lights for better visibility. Do not use the vehicle in reduced visibility conditions.

Do not use the machine before the hydraulic system oil has reached the appropriate temperature. It is recommended to drive the machine at 60-70% of its power for the first 100 hours.



Before starting to drive or activate the equipment, ensure that there is nobody in the surrounding working area. Should anyone enter into the manoeuvring zone, stop the machine.



On carrying out work on site, the overall height and width of the machine must always be taken into consideration. The loading limits of the land, floor, ramps, etc. on which is to be operated must be known.

Whenever possible, avoid crossing or going over obstacles: large irregularities in the ground, rocks, felled trunks, steps, ditches, jumps and paths may cause the machine to tip-over.

- During transport or operation in proximity of high-tension wires, the safety distance must be respected.
- Do not transport persons on the machine.
- Do not use the bucket to lift or transport persons.
- For safety reasons, do not try to climb on or of the machine while it is moving.
- In case of fire, do not extinguish with water. First of all, use the fire extinguisher, smother the fire with sand or earth, or better, cover the fire with a blanket or cloth.
- When driving the machine pay particular attention to the condition of the ground; moderate speed in the case of rain, snow or ice.



The machine must be driven and manoeuvred only from the driver's seat, in a seated position with the safety bar lowered and with safety belts fastened.

EMERGENCY EXIT



In case of **EMERGENCY** the operator can use n. 2 escape routes. These are the front opening and the rear window of the driver's cabin.

REAR WINDOW:

To remove the glass pull the relative peg (**ref. 1**) positioned on the central part of the rubber seal and remove the insert it includes. Push the glass towards the outside with force (**ref. 2**) and exit from the vehicle.

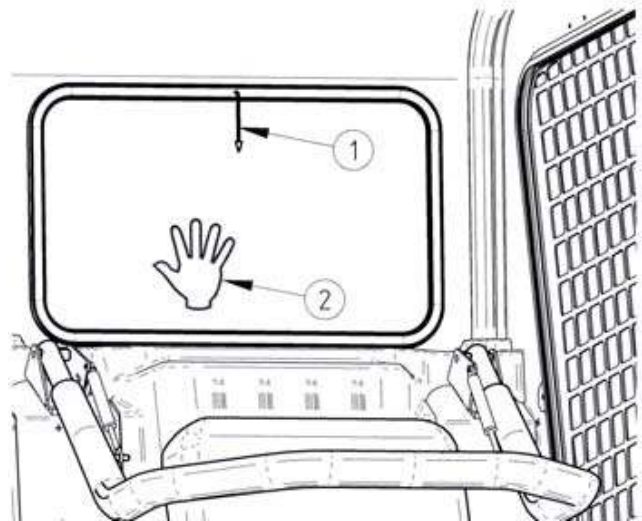

The rear window safety exit is **not suitable** for use in environments where **polar clothing is required**.

N.B.: In machines equipped with a front door, which also becomes an emergency exit, act as follows:

Pull the special peg (**ref. 3**) positioned in the upper central part of the glass seal, push the glass out using the feet (**ref. 4**) and exit from the vehicle.

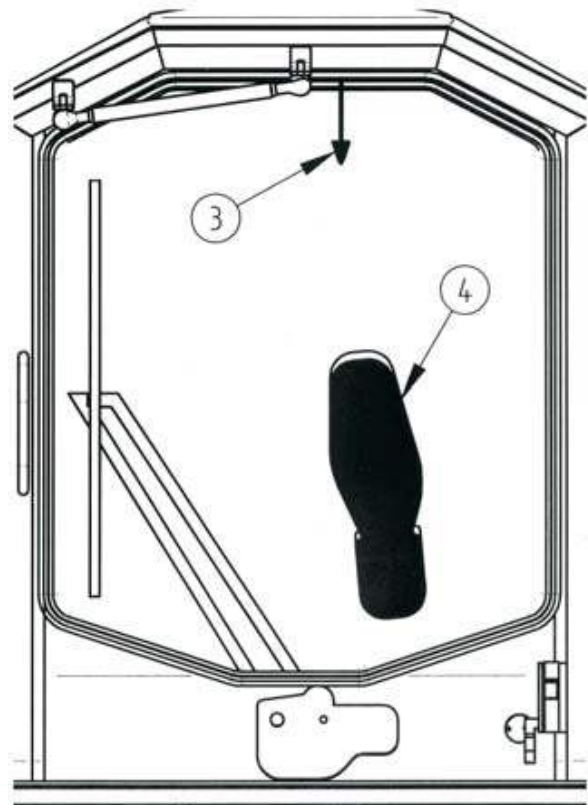

MOVEMENT ON SLOPES

Movement on slopes and craggy areas must be carried out with caution; a high risk exists for the operator and whoever is working in the area. To limit risks to a minimum follow the indications below.

- The loaded shovel must always be upstream, both in ascent and in descent.
- The empty shovel must always be downstream, both in ascent and in descent.
- The load must always be as low as possible.
- Avoid travelling over land where lateral and longitudinal slopes are both present.
- Never pass across slopes.
- Ascent and descent must be carried out by following the slope in a straight line and not at an angle or in an oblique manner.

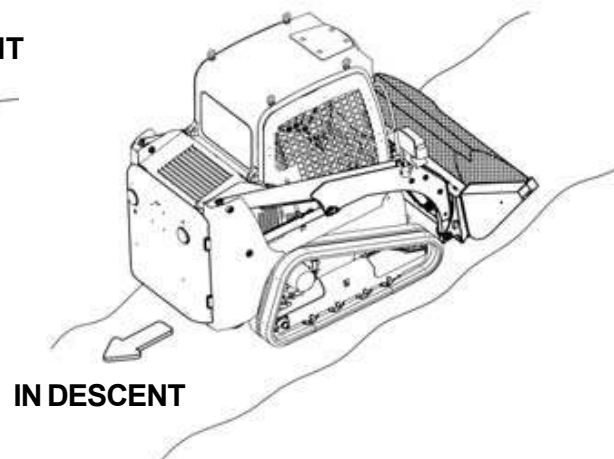
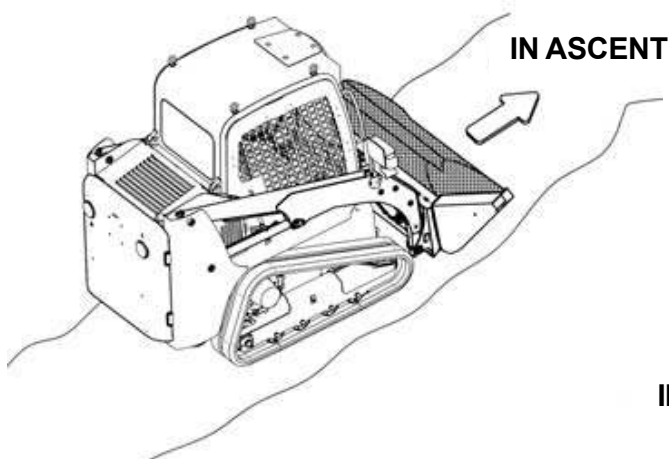
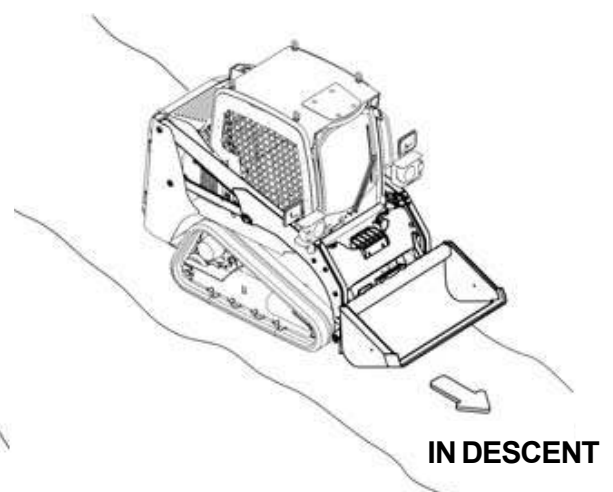
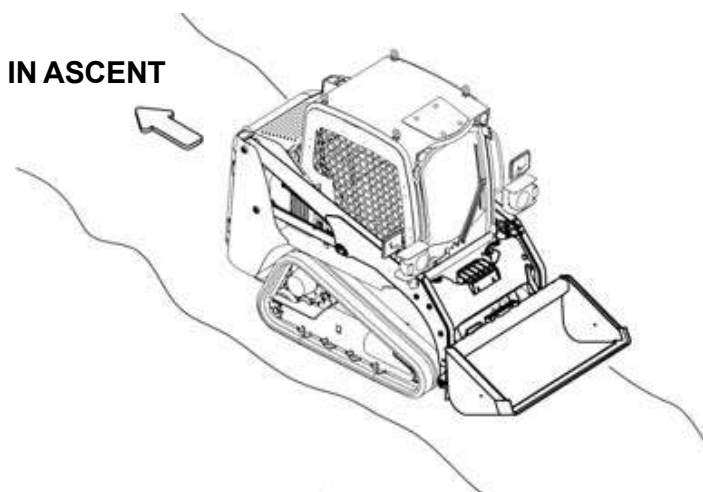
MOVEMENT**WITH LOADED SHOVEL****WITH EMPTY SHOVEL**

SAFETY REGULATIONS FOR STOPPING AND PARKING



Never leave the machine with the engine running.

After leaving the driver's seat, and after ascertaining that there are no persons near the machine, slowly lower and rest the equipment on the ground. Set the controls in the rest position.

If possible, park the machine in an area where no other machines are operating and where there is no vehicle traffic.



Select a solid and level surface. If this is not possible, arrange the machine in a position transverse to the slope, ensuring that there is no danger of sliding.

In public places or when visibility is reduced, place barriers around the machine to keep persons away.

MAKING THE LIFTING ARMS SAFE



If the machine malfunctions or blocks with the arm raised it is necessary to make them safe, by bringing them to the ground.

This is a very delicate operation that must be carried out by following the indications below.

- 1- The operator **must remain seated**, with safety belts fastened.
- 2- The area around the machine **must be completely cleared of people**.
- 3- Move the key inserted in the ignition commutator to position "1" (Ref. 2).
- 4- Press the lifting arms safety activation deactivation button (Ref. 4).
- 5- Successively press the lifting arms fluctuation button (Ref. 5) and the lifting arms descend immediately

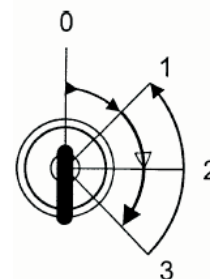
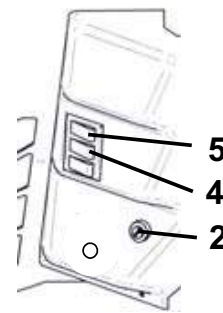

**RANGER OF SHEARING
RANGER OF CRUSHING
FATAL INJURIES**



ATTENTION

In case of EMERGENCY it is possible to block arm descent by pressing the same button again (Ref. 5). **This operation must be carried out exclusively to make the lifting arms safe.**

FIRE-EXPLOSION PREVENTION REGULATIONS

Flames or sparks can cause the battery and fuel to explode and therefore set fire to the machine. To avoid and prevent the causes please follow the advice given below.

Equip the machine with an extinguisher. After any use, reload or replace it. The extinguisher must always be in perfect working order.

- Do not short-circuit the battery clamps with keys or metal objects; any sparks could initiate flaming of the machine's fuel, oils and lubricants.
- Do not weld, grind, smoke or light flames near to the battery or fuel tank.
- When replacing the battery follow the indications supplied in the relative chapter.
- Always keep the machine clean and check any type of leak that may occur.
- Check efficiency and integrity of the electric plant – possible cause of starting a fire.
- Always clean the machine well after use as deposits of inflammable debris, in contact with the hot parts of the machine, could increase the fire risk. The risks increase if this debris is in contact with the exhaust box or near to the hot parts of the engine.



Do not use the machine in environments where dusts and gas are present, or in a generally inflammable atmosphere or when the machine's exhaust pipe can come into contact with inflammable substances.



DANGER OF FIRE-EXPLOSION