

# OPERATION MANUAL

**SK135SR-7**  
**SK140SR<sub>LC</sub>-7**  
**SK140SR<sub>L</sub>-7**

APPLICABLE No.

SK135SR-7 YY09045001~

SK140SR<sub>LC</sub>-7 YY09045001~

SK140SR<sub>L</sub>-7 LK09006001~



READ, UNDERSTAND AND FOLLOW ALL SAFETY PRECAUTIONS AND INSTRUCTIONS FOUND IN THIS MANUAL BEFORE OPERATING THE MACHINE.

Book Code No. **S2YY00041ZE05**

2021.09

Destination : ANZ





## IMPORTANT INFORMATION

PREFACE .....	0-3
STORE OPERATION & MAINTENANCE MANUALS ON THE MACHINE .....	0-4
SAFETY INFORMATION IN MESSAGES OR LABELS IN THIS MANUAL AND ON THE MACHINE .....	0-5
SAFETY LABELS .....	0-6
SUMMARY OF THE MACHINE .....	0-7
QUALIFICATION FOR OPERATING THE MACHINE .....	0-9
CAB WITH ROPS (ROLL-OVER PROTECTIVE STRUCTURE)/ FALLING OBJECTS PROTECTIVE STRUCTURE .....	0-10
ORDERING PARTS AND SERVICE .....	0-11
WARRANTY .....	0-12
IMPORTANT NOTIFICATION .....	0-13

## 1. SAFETY INSTRUCTIONS

1.1 SAFETY LABELS & DECALS .....	1-3
1.1.1 ALWAYS MAKE SURE ALL OF THE SAFETY LABELS ARE LEGIBLE AND NOT DAMAGED .....	1-3
1.1.2 "DO NOT OPERATE" TAG .....	1-3
1.1.3 LOCATION OF SAFETY LABELS & DECALS .....	1-4
1.1.4 SAFETY LABELS .....	1-7
1.2 PRE-START SAFETY .....	1-13
1.2.1 OPERATION RULES .....	1-13
1.2.2 PROTECTION TOOLS .....	1-14
1.2.3 ABNORMAL AND EMERGENCY CONDITION .....	1-15
1.2.4 POTENTIAL HAZARDS WHEN OPERATING .....	1-16
1.2.5 FIRE PREVENTION .....	1-19
1.2.6 GETTING ON AND OFF THE MACHINE .....	1-20
1.2.7 PRE-START UP INSPECTION ON THE MACHINE .....	1-21
1.3 SECURE VISIBILITY .....	1-23
1.3.1 BE AWARE OF YOUR SURROUNDINGS .....	1-23
1.4 PRECAUTIONS FOR OPERATION .....	1-24
1.4.1 STARTING .....	1-24
1.4.2 TRAVELING .....	1-28
1.4.3 PROHIBITED OPERATIONS .....	1-31
1.4.4 SAFETY CHECK ON THE PARKING MACHINE .....	1-37
1.5 AT THE END OF EACH SHIFT .....	1-39
1.6 PRECAUTIONS OF INSPECTION & MAINTENANCE .....	1-40
1.6.1 PERIODIC INSPECTIONS .....	1-40
1.6.2 BEFORE INSPECTION & MAINTENANCE .....	1-41
1.6.3 DURING INSPECTION & MAINTENANCE .....	1-42
1.6.4 CAUTION IN HANDLING OF WELDING .....	1-47
1.6.5 AFTER COMPLETION OF MAINTENANCE .....	1-48
1.7 PRECAUTIONS FOR BATTERY .....	1-49
1.7.1 HANDLING THE BATTERY .....	1-49
1.8 HANDLING OF THE ACCUMULATOR OR GAS SPRING .....	1-50

## 2. MACHINE FAMILIARIZATION

## [CONTENTS]

2.1	BASIC COMPONENTS OF THE MACHINE .....	2-3
2.2	OPERATOR'S STATION NOMENCLATURE .....	2-5
2.3	MONITOR .....	2-7
2.3.1	NORMAL SCREEN .....	2-7
2.3.2	SWITCH DISPLAY .....	2-8
2.3.3	NOTIFICATION ICON.....	2-8
2.3.4	HYDRAULIC OIL TEMPERATURE METER .....	2-9
2.3.5	FUEL LEVEL METER.....	2-9
2.3.6	ENGINE COOLANT TEMPERATURE METER .....	2-10
2.3.7	DEF/ADBLUE LEVEL GAUGE .....	2-10
2.3.8	SWITCH BOX.....	2-11
2.3.9	SETTING MENU SCREEN .....	2-13
2.3.10	SWITCH SETTING SCREEN .....	2-24
2.3.11	TRAVEL SPEED SELECTION.....	2-27
2.3.12	WORK MODE SELECTION .....	2-28
2.3.13	SWITCHING ATTACHMENT MODE .....	2-29
2.3.14	AUTO ACCELERATION ON/OFF SELECTION .....	2-35
2.3.15	WIPER SWITCH .....	2-36
2.3.16	WASHER SWITCH.....	2-36
2.3.17	BUZZER STOP SWITCH.....	2-37
2.3.18	WARNING DISPLAY SCREEN.....	2-40
2.3.19	CLOGGING DETECTOR OF HYDRAULIC OIL FILTER .....	2-44
2.4	HANDLING OF SWITCHES AND METERS .....	2-45
2.4.1	STARTER SWITCH.....	2-45
2.4.2	ENGINE THROTTLE.....	2-45
2.4.3	WORKING LIGHT (BOOM AND DECK).....	2-46
2.4.4	WORKING LIGHT SWITCH (CAB LIGHT) .....	2-46
2.4.5	MANUAL REGENERATION SWITCH .....	2-46
2.4.6	CAP (OPTION SWITCH) .....	2-47
2.4.7	HORN SWITCH .....	2-47
2.4.8	EMERGENCY ACCEL.....	2-48
2.4.9	SWING PARKING BRAKE RELEASE SWITCH.....	2-49
2.4.10	KPSS RELEASE SWITCH .....	2-49
2.4.11	ENGINE STOP SWITCH.....	2-50
2.4.12	12 V POWER SUPPLY .....	2-50
2.4.13	USB PORT/EXTERNAL INPUT TERMINAL (AUX) .....	2-51
2.5	HANDLING OF LEVERS AND PEDALS.....	2-52
2.5.1	LOCATION OF LEVERS AND PEDALS .....	2-52
2.5.2	CONTROL LOCK LEVER .....	2-53
2.5.3	OPERATOR CONTROL LEVERS .....	2-54
2.5.4	TRAVEL LEVER & PEDAL.....	2-55
2.5.5	DOZER OPERATION LEVER .....	2-56
2.6	HANDLING OF FUSE & RELAY BOX .....	2-57
2.6.1	ABOUT FUSE & RELAY BOX .....	2-57
2.6.2	REPLACING FUSES.....	2-57
2.6.3	FUSE CAPACITY AND CIRCUIT NAME .....	2-58
2.7	HANDLING OF FUSIBLE LINK (FOR STARTER) .....	2-59

2.7.1	FUSIBLE LINK INSPECTION/REPLACEMENT.....	2-59
2.8	CONTROLLER .....	2-60
2.9	HANDLING OF RADIO .....	2-61
2.9.1	NAME OF EACH PART .....	2-61
2.9.2	ON-AIR (NORMAL CONDITION) .....	2-62
2.9.3	SWITCHING SOURCE .....	2-63
2.9.4	FM/AM .....	2-64
2.9.5	BLUETOOTH AUDIO FUNCTION, AND USB PORT/EXTERNAL INPUT TERMINAL.....	2-69
2.9.6	PAIRING (REGISTRATION OF DEVICES).....	2-72
2.9.7	TELEPHONE FUNCTION.....	2-74
2.9.8	FILE PLAYING FUNCTION.....	2-76
2.9.9	VOLUME CONTROL.....	2-83
2.9.10	SOUND ADJUSTMENT .....	2-84
2.9.11	CLOCK ADJUSTMENT.....	2-88
2.10	AIR CONDITIONER.....	2-89
2.10.1	GRILLE (AIR OUTLET).....	2-89
2.10.2	AIR CONDITIONER CONTROL PANEL.....	2-90
2.10.3	AIR CONDITIONER OPERATION PANEL.....	2-91
2.10.4	HOW TO USE AIR CONDITIONER .....	2-94
2.10.5	SELF-DIAGNOSIS FUNCTION IN DISPLAY MONITOR.....	2-96
2.10.6	HANDLING AT IN-SEASON/OFF-SEASON .....	2-97
2.11	HANDLING OF SEAT BELT.....	2-98
2.11.1	HOW TO FASTEN SEAT BELT.....	2-98
2.11.2	HOW TO UNFASTEN SEAT BELT .....	2-98
2.12	HANDLING OF OPERATOR'S SEAT (AIR SUSPENSION SEAT).....	2-99
2.12.1	DAMPER ADJUSTMENT.....	2-99
2.12.2	WEIGHT ADJUSTMENT .....	2-100
2.12.3	HEIGHT ADJUSTMENT.....	2-100
2.12.4	RECLINING ADJUSTMENT.....	2-100
2.12.5	FRONT/REAR ADJUSTMENT OF CONTROL STAND.....	2-100
2.12.6	TILT ADJUSTMENT OF CONTROL BOX .....	2-100
2.12.7	FRONT/REAR ADJUSTMENT OF SEAT .....	2-101
2.12.8	TILT ADJUSTMENT OF SEAT SEATING SURFACE .....	2-101
2.12.9	FRONT/REAR ADJUSTMENT OF SEAT SEATING SURFACE.....	2-101
2.12.10	ARM REST ADJUSTMENT .....	2-101
2.12.11	HEAD REST ADJUSTMENT.....	2-101
2.12.12	SEAT HEATER.....	2-101
2.12.13	LUMBAR SUPPORT .....	2-101
2.13	HANDLING PARTS INSIDE CAB.....	2-102
2.13.1	CAB DOOR LOCK.....	2-102
2.13.2	OPENING DOOR FROM INSIDE OF CAB .....	2-102
2.13.3	OPENING/CLOSING FRONT WINDOW (UPPER).....	2-103
2.13.4	REMOVING FRONT WINDOW (LOWER).....	2-104
2.13.5	ROOM LAMP .....	2-105
2.14	EMERGENCY ESCAPE FROM OPERATOR'S STATION .....	2-106
2.15	OTHER ACCESSORIES.....	2-107
2.15.1	TOOL BOX .....	2-107

## [CONTENTS]

2.15.2	GREASE GUN HOLDER .....	2-107
2.15.3	GUARD/SIDE DOOR (WITH LOCK) .....	2-107
2.16	BATTERY POWER-OFF SWITCH .....	2-109
3.	MACHINE OPERATION	
3.1	DAILY MAINTENANCE CHECKS .....	3-3
3.1.1	SUPPORT STAY .....	3-3
3.2	CHECK BEFORE STARTING ENGINE .....	3-5
3.2.1	CHECKING COOLANT LEVEL AND REFILLING .....	3-5
3.2.2	CHECKING ENGINE OIL LEVEL OF ENGINE OIL PAN AND REFILLING .....	3-6
3.2.3	CHECKING FUEL LEVEL AND REFUELING .....	3-8
3.2.4	DRAINING FUEL PRE-FILTER .....	3-9
3.2.5	CHECKING OIL LEVEL OF HYDRAULIC OIL TANK .....	3-10
3.2.6	CHECKING FAN BELT AND AIR CONDITIONING COMPRESSOR BELT .....	3-11
3.2.7	CHECKING RADIATOR, OIL COOLER AND FILTER .....	3-12
3.2.8	CHECKING DEF/ADBLUE LEVEL AND REFILLING .....	3-12
3.2.9	ADJUSTMENT OF OPERATOR'S SEAT .....	3-13
3.2.10	ADJUSTMENT OF MIRRORS .....	3-14
3.2.11	CHECKING DISPLAY OF MONITOR .....	3-18
3.2.12	CHECKING WORKING LIGHT .....	3-18
3.2.13	CHECKING OF AIR CLEANER INLET .....	3-18
3.3	STARTING ENGINE .....	3-19
3.3.1	START-UP UNDER NORMAL TEMPERATURE CONDITIONS .....	3-19
3.3.2	START UP IN COLD CONDITIONS .....	3-21
3.3.3	USING JUMPER CABLES .....	3-22
3.4	STOPPING MACHINE ENGINE .....	3-24
3.5	CHECK AFTER STARTING ENGINE .....	3-25
3.5.1	CHECK OF PILOT CONTROL LOCK LEVER .....	3-25
3.5.2	CHECK OF ENGINE AND MONITOR .....	3-26
3.6	WARMING-UP .....	3-27
3.6.1	ENGINE WARMING-UP .....	3-27
3.6.2	WARMING-UP HYDRAULIC OIL .....	3-28
3.7	AUTO IDLING STOP FUNCTION .....	3-29
3.7.1	RESTART AFTER AUTO IDLE STOP .....	3-29
3.8	WORK MODE SELECTION .....	3-31
3.9	SWITCHING ATTACHMENT MODE .....	3-32
3.10	MACHINE OPERATION .....	3-33
3.10.1	PRECAUTIONS OF MACHINE OPERATION .....	3-33
3.10.2	TRAVEL PROCEDURES .....	3-34
3.10.3	TRAVEL SPEED SELECTION .....	3-36
3.10.4	MACHINE OPERATION IN WATER OR ON SOFT GROUND .....	3-37
3.10.5	GETTING OUT OF SOFT GROUND .....	3-38
3.10.6	SWING AND ATTACHMENT/EQUIPMENT OPERATIONS .....	3-39
3.11	WORK PROCEDURES OF MACHINE .....	3-41
3.11.1	DIGGING WORK .....	3-41
3.11.2	LOADING WORK .....	3-41

3.11.3	GROUND LEVELING WORK .....	3-42
3.12	ALWAYS PARK MACHINE PROPERLY .....	3-43
3.12.1	PARKING MACHINE ON SLOPE .....	3-43
3.13	INSPECTION AND CHECK AFTER OPERATION.....	3-45
3.14	MACHINE OPERATION IN ADVERSE CONDITIONS .....	3-46
3.14.1	OPERATION IN COLD CONDITION.....	3-46
3.14.2	OPERATION AT SEASHORE.....	3-47
3.14.3	OPERATION IN SANDY AND DUSTY AREAS.....	3-47
3.15	PRECAUTIONS FOR LONG-TERM STORAGE .....	3-48
3.15.1	WASHING MACHINE .....	3-48
3.15.2	REFILLING OIL/GREASING .....	3-48
3.15.3	BATTERY .....	3-48
3.15.4	COOLANT .....	3-48
3.15.5	PREVENTION OF DUST AND MOISTURE .....	3-49
3.15.6	PERIODICAL LUBRICATING OPERATION (DURING STORAGE) .....	3-50
3.15.7	TREATMENT AFTER LONG-TERM STORAGE.....	3-50
4.	INSPECTION AND MAINTENANCE	
4.1	GENERAL .....	4-3
4.2	INSPECTING AND MAINTAINING MACHINE.....	4-4
4.2.1	PERIODIC INSPECTION AND MAINTENANCE.....	4-4
4.2.2	PRECAUTIONS OF INSPECTION AND MAINTENANCE .....	4-4
4.2.3	SUPPORT STAY .....	4-5
4.3	EXHAUST GAS CLEANING DEVICE (DOC).....	4-6
4.3.1	ABOUT EXHAUST GAS CLEANING DEVICE .....	4-6
4.3.2	ABOUT AUTOMATIC REGENERATION .....	4-6
4.3.3	ABOUT MANUAL REGENERATION.....	4-7
4.3.4	INSPECTION AND MAINTENANCE.....	4-8
4.3.5	PRECAUTIONS OF USING EXHAUST GAS CLEANING DEVICE .....	4-9
4.4	SCR SYSTEM AND DEF/ADBLUE .....	4-10
4.4.1	SCR .....	4-10
4.4.2	DEF/AdBlue.....	4-10
4.4.3	DEF/AdBlue CIRCUIT AND BATTERY.....	4-10
4.4.4	STORING DEF/ADBLUE .....	4-10
4.4.5	PURCHASING DEF/ADBLUE .....	4-10
4.4.6	LOW DEF/ADBLUE LEVEL .....	4-11
4.4.7	QUALITY PROBLEMS OF DEF/ADBLUE .....	4-11
4.4.8	DRAINING DEF/ADBLUE .....	4-12
4.4.9	FAILURE OF EXHAUST GAS CLEANING DEVICE .....	4-13
4.4.10	EMERGENCY EVACUATION MODE.....	4-14
4.4.11	SCR INSPECTION AND MAINTENANCE .....	4-14
4.5	LUBRICANT, FUEL & COOLANT SPECIFICATIONS.....	4-15
4.6	ABOUT USE OF BIO-OIL (BIODEGRADABLE HYDRAULIC OIL).....	4-17
4.6.1	GREASE AND OIL FOR USE .....	4-17
4.6.2	PRECAUTIONS FOR BIO-OIL .....	4-17
4.6.3	REPLACEMENT INTERVAL OF BIO-OIL.....	4-17

## [CONTENTS]

4.6.4	FLUSHING PROCEDURES OF BIO-OIL .....	4-17
4.7	MAINTENANCE PARTS .....	4-18
4.8	TIGHTENING TORQUES FOR BOLTS & NUTS (SPECIFIC POSITIONS) .....	4-19
4.9	TIGHTENING TORQUES FOR BOLTS & NUTS .....	4-21
4.10	TIGHTENING TORQUES FOR JOINTS & HYDRAULIC HOSES .....	4-23
4.11	INSPECTION AND MAINTENANCE CHART .....	4-25
4.12	MAINTENANCE WHEN REQUIRED.....	4-30
4.12.1	CHECKING AND REPLACING WIPER BLADES .....	4-30
4.12.2	WASHER FLUID INSPECTION .....	4-30
4.12.3	REPLACING BUCKET.....	4-31
4.12.4	REPLACING TOOTH POINT AND SIDE CUTTER.....	4-33
4.12.5	INSPECTION AND ADJUSTMENT OF BUCKET GAP ADJUSTMENT MECHANISM.....	4-36
4.12.6	BLEEDING AIR FROM FUEL PIPING.....	4-37
4.12.7	CLEANING CAB SKYLIGHT .....	4-38
4.12.8	RELEASING INTERNAL PRESSURE IN HYDRAULIC SYSTEM.....	4-39
4.12.9	GREASING ATTACHMENT/EQUIPMENT .....	4-40
4.13	8 HOUR (DAILY) INSPECTION & MAINTENANCE PROCEDURES.....	4-41
4.13.1	GREASING ATTACHMENT .....	4-41
4.14	50 HOUR INSPECTION & MAINTENANCE PROCEDURES .....	4-43
4.14.1	INSPECTING AND MAINTAINING BATTERY.....	4-43
4.14.2	DRAINING WATER AND SEDIMENT IN FUEL TANK.....	4-45
4.14.3	ADJUSTING CRAWLER TENSION .....	4-47
4.15	120 HOUR INSPECTION & MAINTENANCE PROCEDURES .....	4-49
4.15.1	CHECKING ENGINE OIL LEVEL OF SWING REDUCTION UNIT.....	4-49
4.15.2	CHECKING OIL LEVEL OF TRAVEL REDUCTION UNIT .....	4-50
4.16	250 HOUR (3-MONTH) INSPECTION & MAINTENANCE PROCEDURES .....	4-51
4.16.1	ADJUSTING FAN BELT AND AIR CONDITIONING COMPRESSOR BELT.....	4-51
4.16.2	CHECKING INTAKE SYSTEM RUBBER HOSE .....	4-55
4.16.3	CHECKING RADIATOR HOSES .....	4-56
4.16.4	CLEANING OR REPLACING AIR CONDITIONER FILTERS .....	4-58
4.16.5	INSPECTING, CLEANING, OR REPLACING AIR CLEANER ELEMENT.....	4-60
4.16.6	CLEANING OR REPLACING RADIATOR CAP.....	4-62
4.16.7	INSPECTING SCR SYSTEM .....	4-62
4.16.8	CLEANING RADIATOR, OIL COOLER CORE AND FILTER.....	4-63
4.17	500 HOUR (6-MONTH) INSPECTION & MAINTENANCE PROCEDURES .....	4-65
4.17.1	REPLACING ENGINE OIL AND ENGINE OIL FILTER .....	4-65
4.17.2	REPLACING FUEL PRE-FILTER .....	4-68
4.17.3	REPLACING FUEL FILTER .....	4-70
4.17.4	GREASING SWING BEARING.....	4-71
4.17.5	CHECKING SWING BEARING MOUNTING BOLT FOR LOOSENESS .....	4-71
4.17.6	CLEANING FUEL TANK CAP AND STRAINER .....	4-72
4.17.7	LUBRICATING PUSH ROD OF CONTROL LEVER .....	4-73
4.17.8	CHECKING AIR CONDITIONER REFRIGERANT .....	4-74
4.17.9	CLEANING OR REPLACING ELECTROMAGNETIC FUEL PUMP .....	4-76
4.18	1000 HOUR (12-MONTH) INSPECTION & MAINTENANCE PROCEDURES .....	4-78
4.18.1	REPLACING RETURN FILTER .....	4-78
4.18.2	REPLACING AIR BREATHER ELEMENT .....	4-80

4.18.3	CHECKING ENGINE MOUNTING BRACKET FOR TIGHTENING CONDITION.....	4-81
4.18.4	CHECKING BATTERY VOLTAGE.....	4-82
4.19	2000 HOUR INSPECTION & MAINTENANCE PROCEDURES .....	4-83
4.19.1	REPLACING COOLANT .....	4-83
4.19.2	REPLACING OIL IN SWING REDUCTION UNIT .....	4-85
4.19.3	REPLACING OIL IN TRAVEL REDUCTION UNITS .....	4-86
4.19.4	CLEANING SUCTION STRAINER.....	4-87
4.19.5	GREASING SWING REDUCTION UNIT .....	4-89
4.19.6	CHECKING GREASE IN SWING GREASE BATH .....	4-90
4.19.7	CLEANING PILOT LINE FILTER .....	4-91
4.20	5000 HOUR INSPECTION & MAINTENANCE PROCEDURES .....	4-92
4.20.1	REPLACING HYDRAULIC OIL.....	4-92
4.20.2	REPLACING DEF/ADBLUE SUPPLY MODULE FILTER .....	4-95
5.	TRANSPORTATION	
5.1	TRANSPORTATION.....	5-3
5.1.1	STRICTLY OBSERVE TRANSPORTATION RELATED REGULATIONS.....	5-3
5.2	LOADING/UNLOADING THE MACHINE.....	5-5
5.2.1	LOADING .....	5-6
5.2.2	FIXING THE MACHINE .....	5-8
5.2.3	UNLOADING .....	5-9
5.3	MACHINE LIFTING .....	5-10
5.3.1	LIFTING PROCEDURES.....	5-11
5.4	INSTALLING AND REMOVING MIRROR.....	5-12
5.5	TOWING THE MACHINE.....	5-13
5.5.1	TOWING METHOD OF THE MACHINE .....	5-13
6.	SPECIFICATION	
6.1	GENERAL SPECIFICATIONS.....	6-3
6.1.1	SK135SR-7, SK140SR7C-7.....	6-3
6.1.2	SK135SR-7, SK140SR7C-7 (WITH DOZER).....	6-5
6.1.3	SK140SR7C-7.....	6-6
6.2	SHOE TYPES AND USES .....	6-7
6.2.1	SK135SR-7 .....	6-7
6.2.2	SK135SR-7 (WITH DOZER) .....	6-8
6.2.3	SK140SR7C-7 .....	6-8
6.2.4	SK140SR7C-7 (WITH DOZER).....	6-9
6.2.5	SK140SR7C-7.....	6-9
6.3	WORKING RANGES.....	6-10
6.3.1	BACKHOE ATTACHMENT (SK140SR7C-7).....	6-10
6.3.2	BACKHOE ATTACHMENT (SK140SR7C-7).....	6-12
6.4	ATTACHMENT TYPE AND COMBINATION .....	6-13
6.4.1	FRONT VARIATION .....	6-13
7.	MACHINE OPERATION MANAGEMENT SYSTEM	

## [CONTENTS]

7.1	MACHINE OPERATION MANAGEMENT SYSTEM .....	7-3
7.2	REMOTE DOWNLOAD SYSTEM.....	7-4
<b>8.</b>	<b>OPTIONAL EQUIPMENT</b>	
8.1	OPERATION OF HYDRAULIC NIBBLER (CRUSHER) AND BREAKER.....	8-3
8.1.1	SELECTION OF NIBBLER (CRUSHER) AND BREAKER .....	8-3
8.1.2	INSTALLATION OF NIBBLER (CRUSHER) OR BREAKER .....	8-3
8.1.3	POTENTIAL HAZARDS WHEN OPERATING .....	8-3
8.1.4	PRECAUTIONS IN USE OF BREAKER.....	8-5
8.1.5	PRECAUTIONS IN USE OF NIBBLER (CRUSHER).....	8-10
8.2	SELECTION OF ATTACHMENT MODE AND SELECTOR VALVE .....	8-15
8.2.1	SWITCHING ATTACHMENT MODE .....	8-15
8.2.2	SWITCHING SELECTOR VALVE .....	8-17
8.3	SWITCHING STOP VALVE .....	8-18
8.4	FLOW RATE ADJUSTMENT.....	8-19
8.5	CONTROL OF PROPORTIONAL HAND CONTROL.....	8-20
8.5.1	EXTRA / ROTARY HAND CONTROL .....	8-20
8.5.2	HORN SWITCH .....	8-21
8.5.3	NIBBLER (CRUSHER) OPERATION .....	8-21
8.5.4	BREAKER OPERATION.....	8-22
8.6	PERIODIC INSPECTION AND MAINTENANCE OF NIBBLER (CRUSHER) AND BREAKER .....	8-23
8.6.1	PERIODIC INSPECTION AND MAINTENANCE CHART OF NIBBLER (CRUSHER) AND BREAKER .....	8-23
8.7	PRECAUTIONS FROM BREAKER MANUFACTURERS.....	8-24
8.8	MULTI-CONTROL VALVE .....	8-25
8.9	QUICK HITCH.....	8-27
8.9.1	QUICK HITCH OPERATION SWITCH .....	8-27
8.9.2	PROHIBITED WORKS .....	8-28
8.9.3	PRECAUTIONS FOR USE .....	8-29
8.9.4	REMOVING FRONT ATTACHMENT.....	8-30
8.9.5	INSTALLING FRONT ATTACHMENT.....	8-31
8.9.6	MANUAL SWITCHING OF PRESSURE REDUCING VALVE FOR QUICK HITCH.....	8-32
8.10	HANDLING OF OPERATOR'S SEAT (MECHANICAL SUSPENSION SEAT) .....	8-33
8.10.1	HEIGHT AND TILT ADJUSTMENT .....	8-33
8.10.2	RECLINING ADJUSTMENT.....	8-33
8.10.3	FRONT/REAR SEAT ADJUSTMENT .....	8-33
8.10.4	FORWARD AND REARWARD ADJUSTMENT OF CONTROL STAND .....	8-34
8.10.5	ARM REST ADJUSTMENT .....	8-34
8.10.6	HEAD REST ADJUSTMENT .....	8-34
8.10.7	SUSPENSION ADJUSTMENT .....	8-34
8.11	FLOATING DOZER.....	8-35
8.12	HANDLING THE LONG RANGE ATTACHMENT .....	8-36
8.12.1	CAUTION ON OPERATION .....	8-36
8.12.2	CAUTION ON TRANSPORTING .....	8-37
8.12.3	GENERAL SPECIFICATIONS .....	8-38
8.12.4	WORKING RANGE .....	8-40



9. SPECIAL PROCEDURES

9.1 SPECIAL PROCEDURES AT ENGINE FAILURE .....9-3

9.2 LOWERING ATTACHMENT TO GROUND.....9-4

9.3 RELEASING TRAVEL MOTOR BRAKES .....9-6

9.4 RELEASING SWING BRAKES.....9-9

    9.4.1 SWING BRAKE RELEASE PROCEDURE WITH HYDRAULIC HAND PUMP .....9-9

    9.4.2 RELEASING SWING BRAKE BY DISASSEMBLY .....9-12

[CONTENTS]

# IMPORTANT INFORMATION



## PREFACE

- Read, understand and follow the safety messages and instructions in this manual and the safety messages on the machine. If these safety messages are not followed, serious injury or death could occur.
- Always be aware of your surroundings when operating this machine and understand the capabilities of this machine and the attachment/equipment.
- Always use caution to safely operate this machine.



### Use of this machine and this manual

- Improper operation, inspection, maintenance or repair of this machine may cause serious injury, death or damage to the machine.
- If a license or other special qualification is required to operate a hydraulic excavator in the country where this machine will be operated, all operators of this machine must meet those requirements and have a valid (not expired) license or qualification.
- Do not operate this machine for the first time or perform any inspection, maintenance or repair on this machine, until you have carefully read and understand the operation, inspection, maintenance, and repair information in this manual.
  - Operation related activities include setting up, rectifying malfunctions and the disposal of materials.
  - Maintenance related activities include lubrication, maintenance, inspection and repair work.
  - Transportation related activities include loading and unloading the machine.
- For machines equipped with KOBELCO approved attachments, read the section related to the specialized attachments in this manual and any additional manuals for the specialized attachment. Use of the unapproved attachment/equipment voids KOBELCO's liability for the machine.
- Do not remove this manual from this machine.
- If this manual is lost, damaged or unreadable, order a replacement from your KOBELCO authorized dealer.
- This manual is a part of this machine and should be transferred with the machine to new users or owners.
- Always use genuine KOBELCO parts. Do not use aftermarket or non-KOBELCO parts on your machine.
- Manufacturers cannot anticipate every possible scenario and potential hazard that may arise during operation, inspection and maintenance activities. Therefore, the warnings in this manual and on the product may not communicate all of the possible safety precautions for your situation. When performing any operation, inspection, maintenance and repair activities that are not contained in this manual, proceed at your own risk and do not perform any unsafe acts. You should also ensure the machine will not be damaged or create an unsafe condition by your actions. Always follow the safety procedures in this manual and for your worksite. Never perform any task or operation prohibited by this manual.
- If a tool, procedure, work method or operating technique not specifically recommended by KOBELCO is used, you must evaluate that it is safe for yourself and others to proceed. You should also ensure the machine will not be damaged or create an unsafe condition by the operation, maintenance and/or repair procedures you choose. Never perform any task or operation prohibited by this manual.
- The information, specification, and illustrations in this manual are based on information available at the time it was written. KOBELCO is committed to continuous improvement of the safety systems and features of its products, and may change the specifications, torques, pressures, measurements, adjustments, illustrations, and other content at anytime without any obligation to notify the users/owners of these changes. Your KOBELCO authorized dealer will have the most current information available.
- Should there be questions, errors, omissions or other issues that need to be communicated to the manufacturer, contact your KOBELCO authorized dealer.
- KOBELCO provides machines produced in accordance with regulations and standards of a country in which the machine is sold to the first owner. If you have a machine purchased in a foreign country or from a person or company in another country, your machine may lack safety devices or machine components or not meet a safety standard required in your country. Please contact your KOBELCO authorized dealer to ask whether your machine's specifications meet the regulations and the standards in your country.

The copyright of this manual belongs to KOBELCO CONSTRUCTION MACHINERY CO., LTD. Copy, reproduction, distribution, and delivery (including these actions on the Internet) of all or part of this manual are prohibited without permission of KOBELCO CONSTRUCTION MACHINERY CO., LTD.

---

## STORE OPERATION & MAINTENANCE MANUALS ON THE MACHINE

Always store all manuals for this machine and any attachments, including this manual and the related manuals, in the pocket located at the rear side of the operator's seat. Check the manuals are in this location as a part of your pre-start inspection. If the manuals are not present during your pre-start inspection, inform your supervisor and order replacement manuals from your KOBELCO authorized dealer.

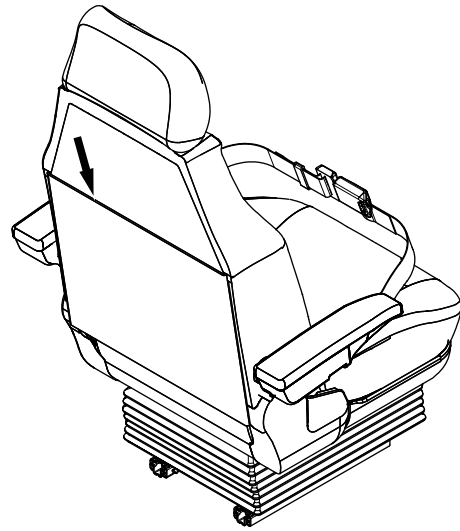

# SAFETY INFORMATION IN MESSAGES OR LABELS IN THIS MANUAL AND ON THE MACHINE

**“Many accidents are the result of not following basic safety precautions and could have been avoided by recognizing potentially hazardous situations.”**

Proper risk assessment can prevent many accidents from occurring. During operation, always pay attention to the potential hazards near the machine and at your worksite.

- Improper operation, inspection, maintenance and repair could cause serious injury, death or property damage. Before operating, inspecting and maintaining this machine, carefully read and understand this manual, the related manuals, and any attachment manuals that may be provided to you.
- Only allow trained and experienced personnel to operate, to inspect and to maintain this machine. These individuals must also comply with all applicable employment, industry, and governmental rules, standards, and regulations.



**This safety alert symbol identifies important safety messages in this manual. When you see this symbol, be alert, your safety is involved, carefully read the message that follows, and inform other operators.**

Many safety messages in this manual or on the labels on this machine contain signal words. Signal words are used to identify safety messages and property damage messages and designate a level of hazard seriousness. Many of these safety messages may also contain avoidance information to hazardous events.

The three signal words are DANGER, WARNING and CAUTION. Each alerts the viewer to the existence and relative seriousness of a hazard. They are reserved for personal injury hazards.

Safety signs identified by DANGER shall be used sparingly and only for those situations presenting the most serious hazards. Hazards identified by WARNING present a lesser degree of risk of injury or death than those identified by DANGER.



DANGER indicates a hazard with a high level of risk which, if not avoided, will result in death or serious injury.



WARNING indicates a hazard with a medium level of risk which, if not avoided, could result in death or serious injury.



CAUTION indicates a hazard with a low level of risk which, if not avoided, could result in minor or moderate injury.

Other than the above-mentioned signal words, the following words identify important information which must be kept for the protection of the machine and may be helpful for the operator.



Notice indicates information considered important, but not hazard related . (e.g., messages related to property damage)

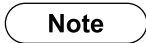

Note indicates information that may be helpful for the operator.

## SAFETY LABELS

Safety labels are affixed to machine to alert the operator and surrounding personnel of hazardous situations during operation, inspection or maintenance.

There are two types of "safety labels" on this machine. One is "SAFETY LABEL INCLUDING SIGNAL WORDS" and the other is "PICTORIAL ONLY SAFETY LABELS".

Example of the safety label including signal words



Example of a pictorial only safety label

The pictorial only safety label is used to alert the operator and surrounding personnel of potentially hazardous situations.

For pictorial only safety label, the hazard pictorial is in the upper or left box, and the avoidance information is in the lower or right box.

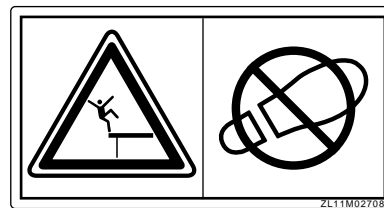



# SUMMARY OF THE MACHINE

## APPLICABLE WORKS

Use this machine in the following applications:

- Digging
- Trenching
- Loading
- Leveling
- Demolishing
- Breaker work

Never use the machine for any purpose other than the above applications.

If you use the attachment which KOBELCO did not supply, read, understand and follow the safety messages and instructions in the applicable manual described by the attachment manufacturer.

For details of work procedures, please refer to "MACHINE OPERATION" in Chapter 3 and "OPTIONAL EQUIPMENT" in Chapter 8.

## FRONT, REAR, RIGHT & LEFT OF THE MACHINE

This manual refers to the front, rear, right & left of this machine as seen when sitting in the operator's seat with the machine in the normal travel position. The normal travel position is when the idler wheels are positioned at the front under the cab and the drive sprockets are positioned at the rear.

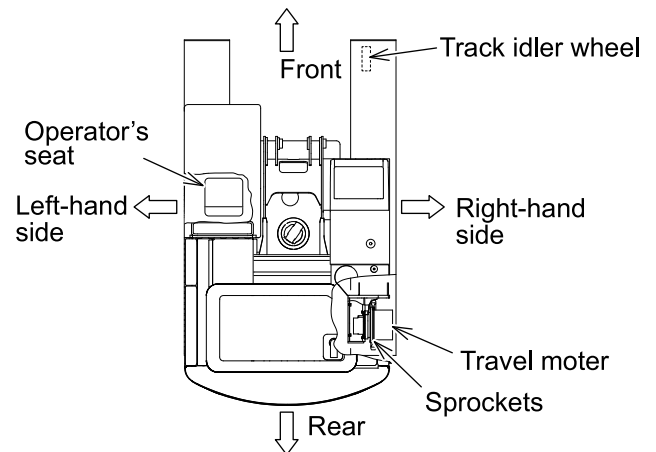

## OPERATING CONDITION

This machine is intended to be operated in the ambient temperature of -20 degrees C to 40 degrees C (-4 degrees F to 104 degrees F) with the well-maintained condition.

Outside this temperature range, sufficient machine performance may not be obtained.

## BREAK-IN OPERATION

Prior to shipment, this machine was inspected and adjusted by KOBELCO. Future performance and service life of this machine depends on how the machine is operated during the break-in period.

Hour Meter	Load Status
Less than 10 hours	About 60%
Less than 100 hours	About 80%
100 hours and more	Full load

### During the break-in period

- Always sufficiently warm-up the engine and the hydraulic oil.
- Do not operate with loads that exceed the recommended load status for each phase shown in the table or operate at high speeds.
- Do not perform a sudden start, sudden acceleration, or other sudden changes in engine speed.
- Avoid unnecessary sudden stops or sudden changes in driving direction.
- Do not operate the engine at high speed for extended periods of time.

## QUALIFICATION FOR OPERATING THE MACHINE

If a license or other special qualification is required to operate a hydraulic excavator in the country where this machine will be operated, all operators of this machine must meet those requirements and have a valid (not expired) license or qualification.

Instruct that only skilled trained operators may operate the machine. The operator shall:

- Receive training in the proper operation of this machine;
- Understand the capabilities and limitations of this machine;
- Become familiar with the construction of this machine and the hazards involved based on training and experience;
- Confirm that the machine is properly maintained and is in good condition;

Read and properly understand the warnings, instructions, and operating procedures in this manual.

# CAB WITH ROPS (ROLL-OVER PROTECTIVE STRUCTURE)/ FALLING OBJECTS PROTECTIVE STRUCTURE

- The machine cab is equipped with ROPS (roll-over protective structure) and top guard. The ROPS and top guard, fitting supports, and fastening elements on the machine are integral parts of the structure.
- When the machine is used at the work site where falling objects may hit the cab, always have the top guard installed and inspect them on a periodic basis to ensure the top guard have not been damaged. The impact from objects striking the top of the cab could result in a potential crush hazard and result in serious injury or death.
- Any damage to the protective structures or the cab caused by collision, corrosion or fire are required to be inspected carefully by appropriate personnel. All damaged parts must be replaced with genuine KOBELCO parts to ensure the protective structures will be restored to their original specifications. Before making any changes to the cab, replacing the whole structure, or replacing the ROPS or top guard, contact your KOBELCO authorized dealer.
- To prevent serious injury or death, do not attempt to weld, to drill, to straighten or to repair the protective structures. Never attach any devices to lift the cab on the protective structure. Any type of modification may affect the structural integrity of the protective system and result in a complete loss of protective capability. Consult your KOBELCO authorized dealer to determine this structure's limitations without voiding its certification. Failures to contact your KOBELCO authorized dealer may void your warranty.
- Pay attention to the operating mass. If the operating mass exceeds MAX. MASS (maximum operating mass) described on ROPS CERTIFICATION with the special attachment or others installed, it will cause insufficient function, resulting in serious injury or death, should the machine tips/rolls over.

OPERATOR PROTECTIVE GUARDS CERTIFICATION	
This structure is tested and meets the requirements of TOP GUARD:LEVEL(1), ISO 10262:1998.	
PRODUCT IDENTIFICATION NUMBER	MACHINE MODEL
SERIAL No.	
<b>WARNING</b> -The modification and rework causing the deterioration of the strength are not allowed. -Don't use the parts other than the specified parts.	
PRODUCED BY KOBELCO CONSTRUCTION MACHINERY CO., LTD. TOKYO, JAPAN.	
YY20T0398P2	

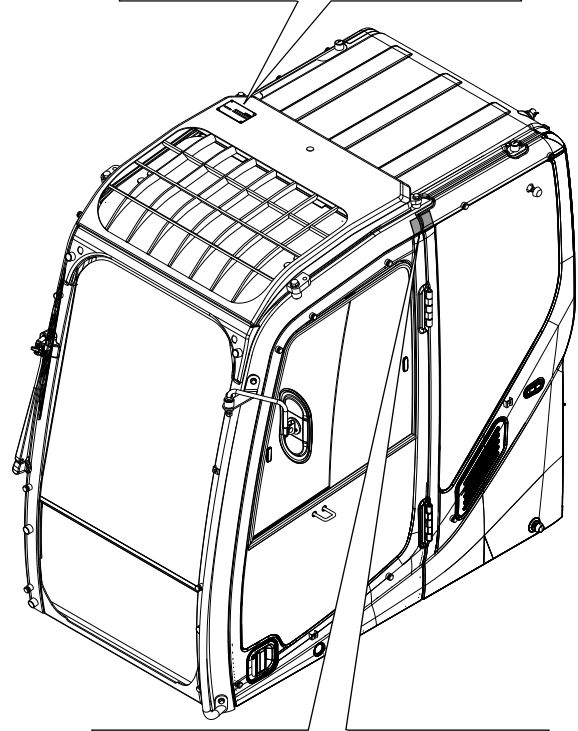

ROPS CERTIFICATION	
This structure is tested and meets the ROPS requirements of ISO 12117-2:2008.	
OPERATOR PROTECTIVE GUARDS CERTIFICATION	
This structure is tested and meets the requirements of TOP GUARD:LEVEL(1), ISO 10262:1998.	
PRODUCT IDENTIFICATION NUMBER	MACHINE MODEL
SERIAL No.	MAX. MASS(kg)
<b>WARNING</b> -The modification and rework causing the deterioration of the strength are not allowed. -Don't use the parts other than the specified parts. -When the skylight is open, the cab doesn't comply with TOP GUARD Level (1).	
PRODUCED BY KOBELCO CONSTRUCTION MACHINERY CO., LTD. TOKYO, JAPAN.	
YY20T0398P2	

# ORDERING PARTS AND SERVICE

When ordering parts and service, have the machine serial number, the engine serial number and the current hours of operation available for your KOBELCO authorized dealer.

The machine serial number and the engine serial number are stamped in the locations shown below. For future reference, confirm and record these numbers in the spaces below.

MACHINE TYPE	MACHINE SERIAL No.	ENGINE SERIAL No.	HOUR METER

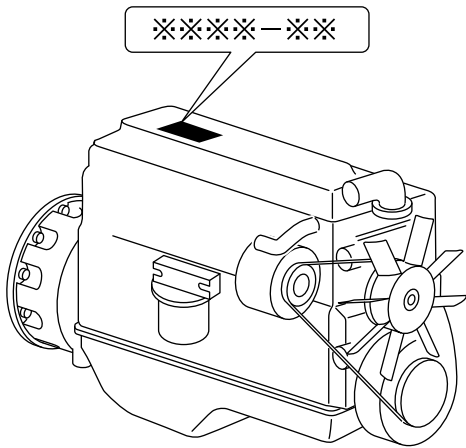

ENGINE SERIAL No.  
("※"means engine serial number)

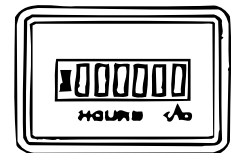
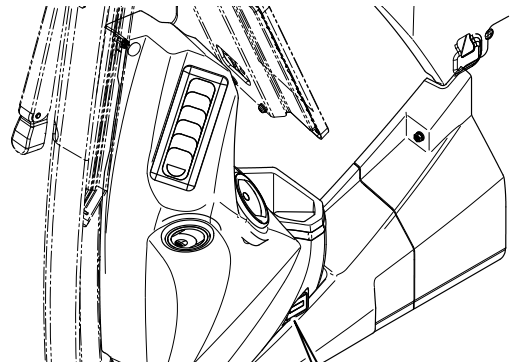

HOUR METER

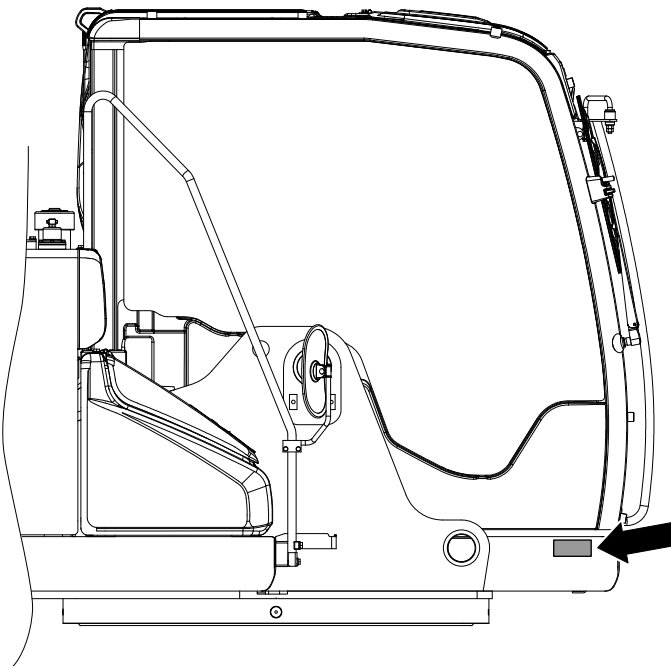

POSITION OF MACHINE SERIAL No. AND MACHINE TYPE

## WARRANTY

This machine is warranted as per the standard warranty. In case of any failures are proved to be KOBELCO's responsibility, KOBELCO will repair or replace any parts or components for free of charge to the extent specified in the standard warranty. KOBELCO shall not be liable for any improper operation, maintenance, modification, and alteration etc., other than described in this manual.

## IMPORTANT NOTIFICATION

To show additional detail of parts and components or show motion of this machine, some illustrations may show the machine with safety related parts and components, including guards, doors, covers and shields, either removed or not in place. To prevent serious injury, death, or property damage, all of the safety related parts and components must be properly installed and secured, before starting this machine.

In addition, some illustrations may show features or functions that differ from your machine. questions, contact your KOBELCO authorized dealer.

### Example

This illustration shows the battery with the cover removed.

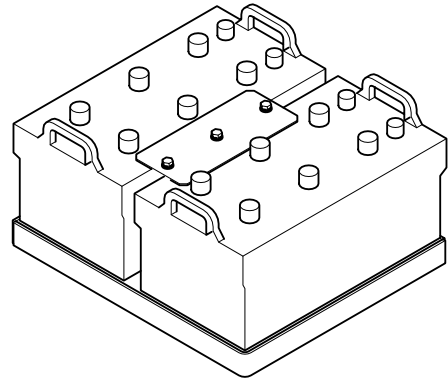





# 1. SAFETY INSTRUCTIONS



## 1.1 SAFETY LABELS & DECALS



### READ THE OPERATOR'S MANUAL

Read, understand and follow the safety messages and instructions in this manual. If these safety messages are not followed, serious injury or death could occur.

### SAFETY MESSAGES

Several labels for specific safety messages are attached to this machine. The exact location and description of the hazards are reviewed in this section.

Please read and understand all safety messages in this manual and on the machine.

#### 1.1.1 ALWAYS MAKE SURE ALL OF THE SAFETY LABELS ARE LEGIBLE AND NOT DAMAGED

- Clean the safety labels or replace the safety labels if you can not read the words or see the illustrations. To clean the safety labels, only use a cloth, water and soap. Do not use any solvent, gasoline or other harsh chemicals to clean the safety labels. Solvents, gasoline or harsh chemicals could loosen the adhesive that secures the safety labels and allow the label to fall off the machine.
- Always replace any safety label that is damaged or missing. If a safety label is attached to a part that is replaced, you will need to install a safety label on the replacement part. Your KOBELCO authorized dealer can provide new safety labels.
- Never remove any safety labels attached to this machine. For all other labels on the machine, clean and replace as needed in accordance with the instructions above.

#### 1.1.2 "DO NOT OPERATE" TAG

Part Number: YN20T02672P1

Use a temporary hang tag to communicate that the machine is out of service. You may need to use more than one temporary hang tag depending on the inspection and maintenance activities to be performed.



1.1.3 LOCATION OF SAFETY LABELS & DECALS

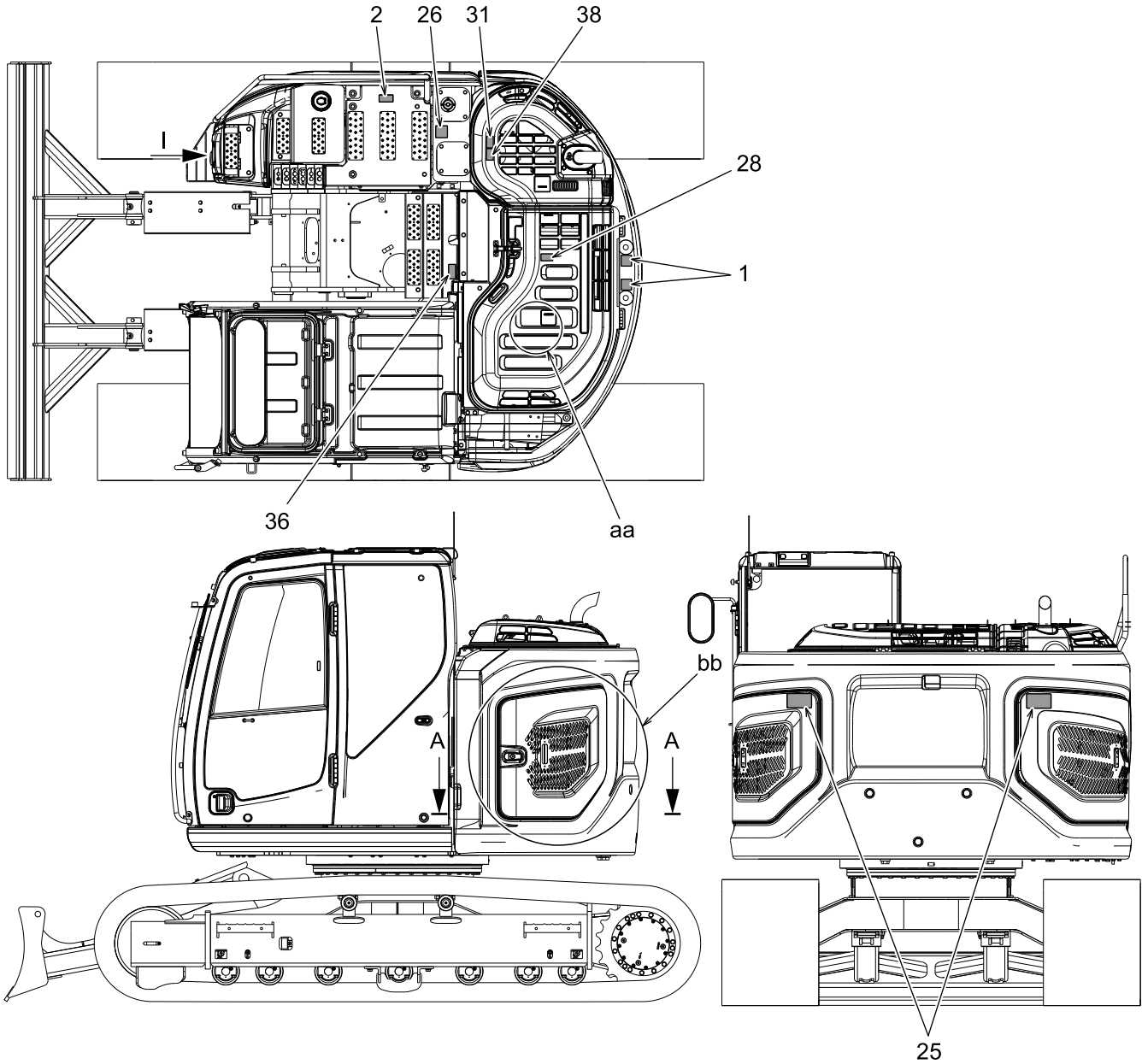

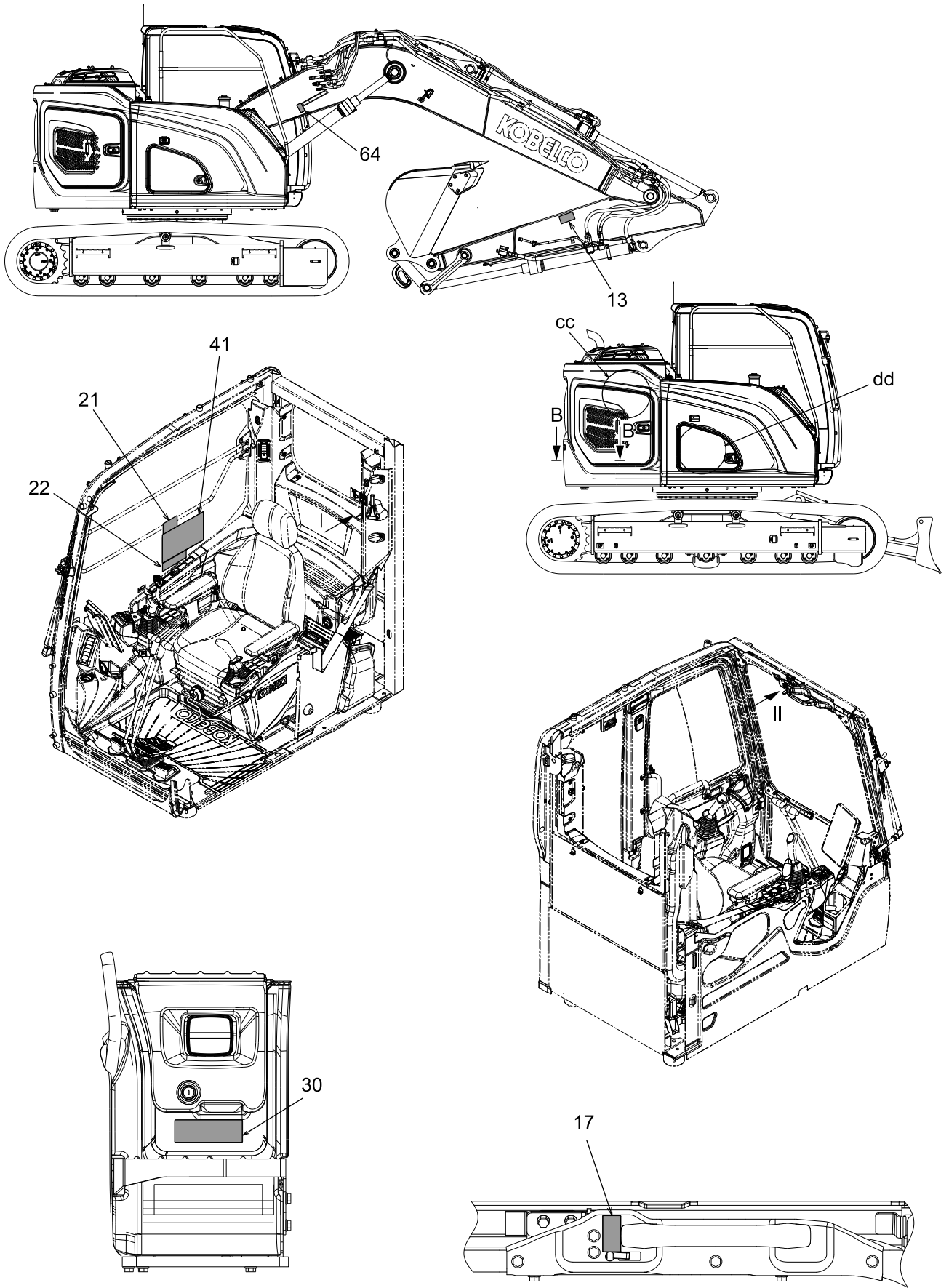

VIEW I

VIEW II

[1. SAFETY INSTRUCTIONS]

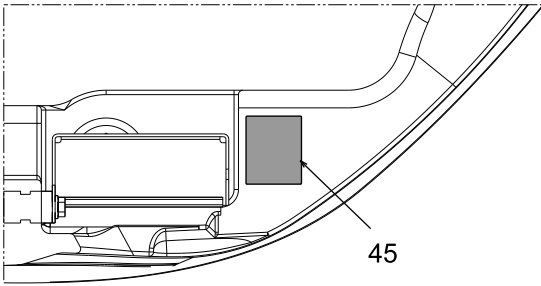

SECTION AA

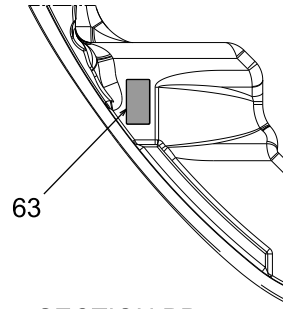

SECTION BB

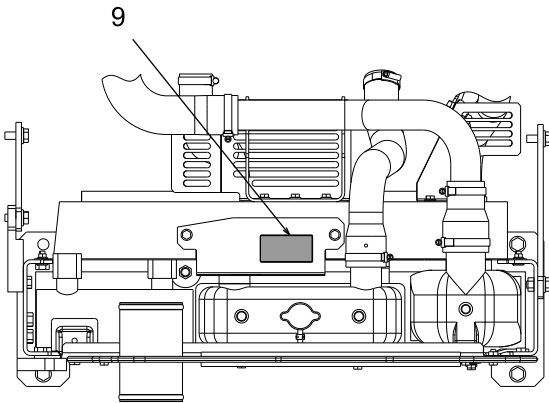

DETAIL aa  
SHOWS INSIDE PANEL

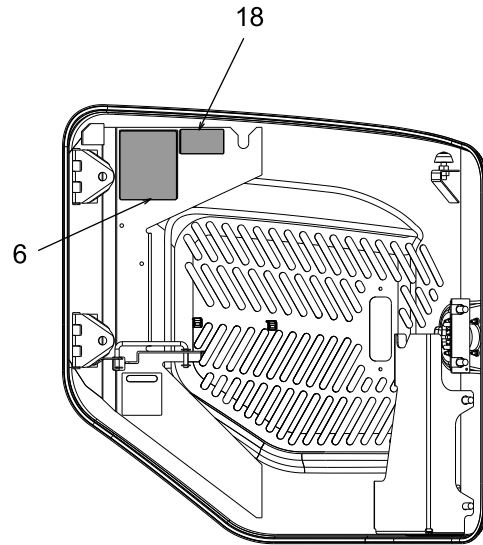

DETAIL bb  
SHOWS BACKSIDE OF PANEL

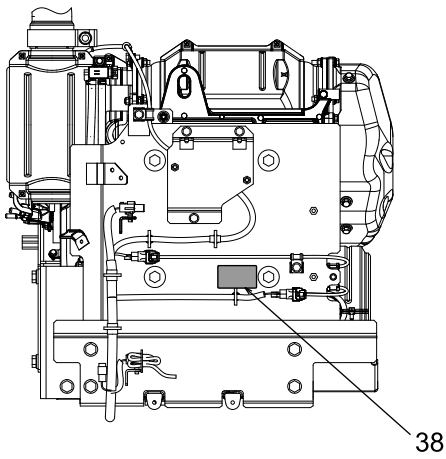

DETAIL cc  
SHOWS INSIDE PANEL

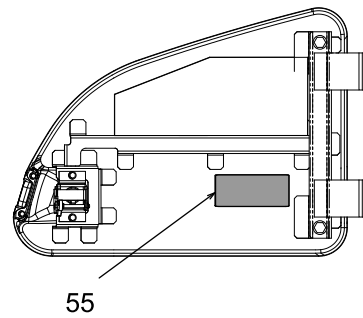

DETAIL dd  
SHOWS BACKSIDE OF PANEL

### 1.1.4 SAFETY LABELS

#### DO NOT USE COUNTERWEIGHT LIFTING EYES

Location:1

Part Number:YN20T02741P1



#### WORKING ABOVE GROUND

Location:2

Part Number:YN20T02743P1

There is a danger of falling when working on areas above ground.

- Do not approach edges.
- Use the appropriate equipment, such as ladders or platform when working above ground. In addition, strap yourself to the proper equipment accordingly.
- Avoid spillage of any oil or grease.
- Clean all slippery substances such as grease, oil, hydraulic oil, mud, ice, and others attached to the steps, handrails, crawlers, ladders, and platforms.
- Do not leave any tools around the working area.
- Use extreme caution to avoid slipping while walking.
- Do not jump on or from the machine. Use the steps and handrails and securely maintain a three point contact while mounting or dismounting at all times.



#### HANDLING BATTERY

Location:6

Part Number:YN20T02746P1

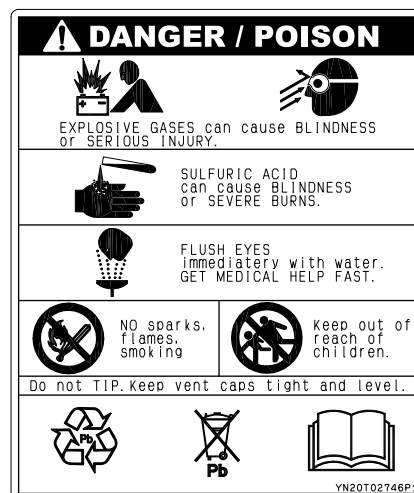

## [1. SAFETY INSTRUCTIONS]

---

### HOT COOLANT

Location:9

Part Number:YN20T02747P1

Never loosen or open the radiator cap when coolant is hot. Stream of hot coolant will spout and could cause burns.

Before opening the radiator cap:

- Cool down the engine completely.
- Cover the radiator with cloth rag.
- Loosen the cap slowly to relieve pressure.

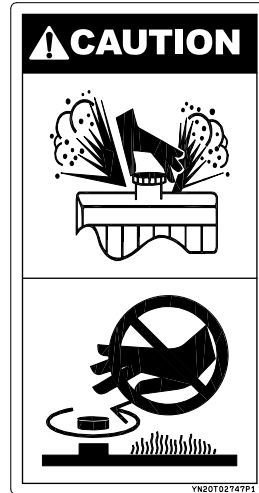

### KEEP CLEAR WORKING AREA

Location:13

Part Number:YN20T02739P1

Make sure the area is clear of obstacles and persons before beginning the operation of the machine.

Always look around before you start the swing operation.

Make sure everyone is cleared in your worksite. Sound horn before beginning swing operation.

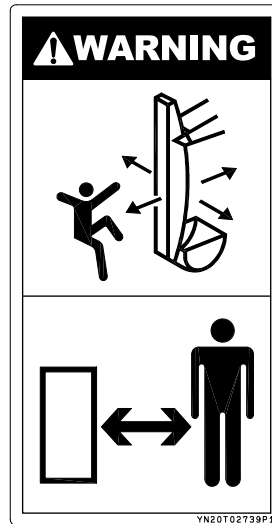

### LOCK THE FRONT WINDOW AT THE OPENING POSITION

Location:17

Part Number:YN20T02764P1

Lock the front window at the opening position securely, or it may slip down and may personal injury.

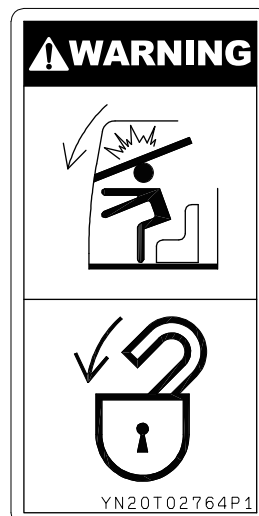



**BATTERY CABLE**

Location:18  
 Part Number:YN20T02761P1  
 Electric hazard may cause injury when mishandling the cable.  
 Read operator manual for safe and proper handling.

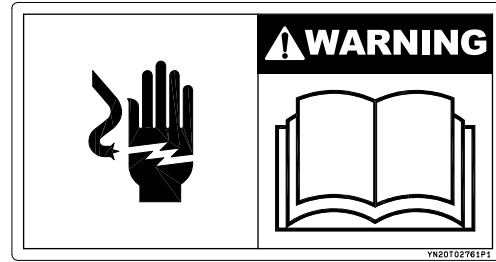

**HANDLING THE QUICK HITCH**

Location:21  
 Part Number:YY20T01577P1



**PRECAUTIONS OF HANDLING QUICK HITCH**

Location:22  
 Part Number:YY20T01578P1

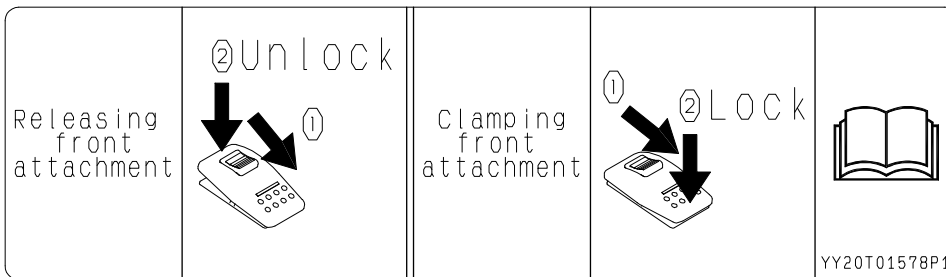

**SWING**

Location:25  
 Part Number:YY20T01617P1  
 Do not enter in the swing area.  
 Stay away from the machine during operation to prevent you from contacting with or being crushed between machine components.

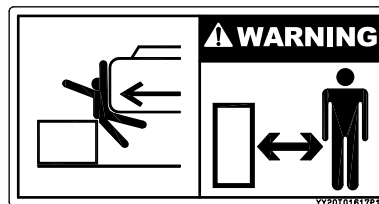

**PRESSURIZED HOT OIL**

Location:26  
 Part Number:YN20T02802P1



1

# [1. SAFETY INSTRUCTIONS]

## WORKING ABOVE GROUND

Location:28

Part Number:YY20T01629P1

There is a danger of falling when working on areas above ground.

- Do not approach edges.
- Use the appropriate equipment, such as ladders or platform when working above ground. In addition, strap yourself to the proper equipment accordingly.
- Avoid spillage of any oil or grease.
- Clean all slippery substances such as grease, oil, hydraulic oil, mud, ice, and others attached to the steps, handrails, crawlers, ladders, and platforms.
- Do not leave any tools around the working area.
- Use extreme caution to avoid slipping while walking.
- Do not jump on or from the machine. Use the steps and handrails and securely maintain a three point contact while mounting or dismounting at all times.

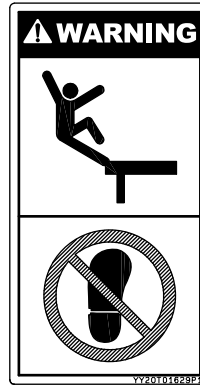

## PRECAUTIONS OF HANDLING DEF/AdBlue

Location:30

Part Number:YN20T02754P1

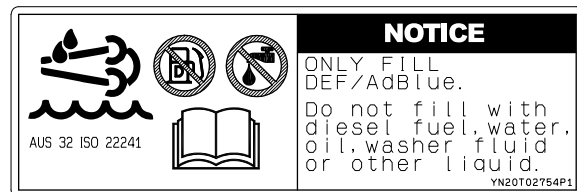

## WORKING ABOVE GROUND

Location:31

Part Number:YN20T02759P1

There is a danger of falling when working on areas above ground.

- Do not approach edges.
- Use the appropriate equipment, such as ladders or platform when working above ground. In addition, strap yourself to the proper equipment accordingly.
- Avoid spillage of any oil or grease.
- Clean all slippery substances such as grease, oil, hydraulic oil, mud, ice, and others attached to the steps, handrails, crawlers, ladders, and platforms.
- Do not leave any tools around the working area.
- Use extreme caution to avoid slipping while walking.
- Do not jump on or from the machine. Use the steps and handrails and securely maintain a three point contact while mounting or dismounting at all times.

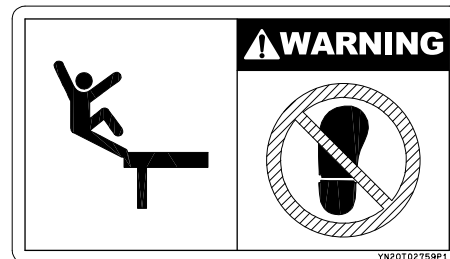

## ENGINE ROTATING PARTS WARNING

Location:36

Part Number:YY20T01570P1

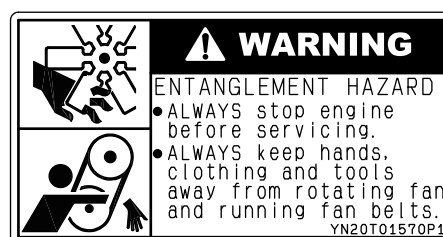

**HOT PARTS**

Location:38

Part Number:YN20T02760P1

	<p><b>CAUTION</b></p> <p>Do not touch exhaust until it cools down.</p> <p>Exhaust may be hot and cause burns.</p> <p style="text-align: right;">YN20T02760P1</p>
--	--

**SAFETY PRECAUTIONS**

Location:41

Part Number:YY20T01724P1

<p><b>DANGER</b></p> <p><b>ELECTROCUTION HAZARD</b></p> <ul style="list-style-type: none"> <li>KEEP the machine and attachments a safe distance from electrical power lines.</li> <li>MAINTAIN maximum possible distance from power lines and NEVER violate minimum clearance.</li> <li>ALWAYS READ and UNDERSTAND operation manuals.</li> </ul>	<p><b>WARNING</b></p> <p><b>FALL HAZARD</b></p> <p>ALWAYS set travel speed select switch to "LOW" when descending slopes or loading and unloading machine.</p>
<p><b>WARNING</b></p> <p>To prevent SERIOUS INJURY, DEATH or PROPERTY DAMAGE, before operating machine:</p> <ul style="list-style-type: none"> <li>CHECK that no one is on, under, and around the machine.</li> <li>CHECK there are not other machines or obstacles in the area surrounding the machine.</li> <li>MAKE SURE control lock lever is "LOCKED" and all control levers and pedals have returned to neutral before starting engine.</li> <li>ALWAYS sound horn to alert people in the vicinity of the machine before moving or starting swing motion.</li> <li>READ and UNDERSTAND operation manuals.</li> </ul>	<p><b>WARNING</b></p> <p>BEFORE operating always check each lever and each pedal matches the operating pattern to prevent SERIOUS INJURY or DEATH from unintended machine movement.</p> <p>Confirm the operating pattern with card displayed in the cab.</p>
<p><b>WARNING</b></p> <p><b>FALL HAZARD</b></p> <p>NEVER attach mirrors or other equipment to handrails.</p> <p>Over time, excessive vibration may weaken handrail.</p>	<p><b>WARNING</b></p> <p><b>CRUSH HAZARD</b></p> <ul style="list-style-type: none"> <li>ALWAYS check clearance between attachment and cab before operation.</li> <li>ALWAYS keep the attachment away from the cab during operation.</li> </ul>
<p><b>WARNING</b></p> <p>To prevent SERIOUS INJURY, DEATH or PROPERTY DAMAGE:</p> <p>READ and UNDERSTAND operation manuals before operating, maintaining, disassembling, assembling or transporting machine.</p> <p>Observe all local laws and regulations as your own responsibility.</p>	<p><b>CAUTION</b></p> <p>Do not use auto idling stop mode when lifting.</p>
<p><b>NOTICE</b></p> <p>Before stopping engine, turn engine throttle to low idle position, perform idle operation for approximately 5 minutes.</p> <p>If engine is suddenly stopped when it is at high temperature such as just after operation, exhaust gas cleaning device may be damaged.</p> <p style="text-align: right;">YY20T01724P1</p>	

**GREASE GUN STORAGE PLACE**

Location:45

Part Number:YT20T01287P1

<p><b>CAUTION</b></p> <p>Be sure to store a grease gun in this grease gun holder.</p> <p style="text-align: right;">YT20T01287P1</p>



# [1. SAFETY INSTRUCTIONS]

---

## HOT PARTS

Location:63

Part Number:YY20T01733P1

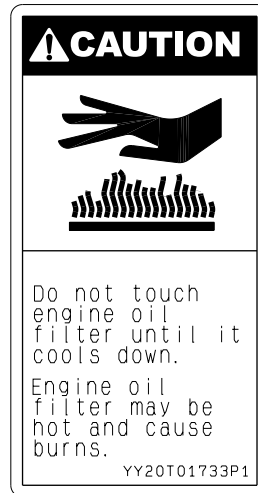

## WORKING ABOVE GROUND

Location:64

Part Number:YY20T01630P1

Do not put your foot on the hand hold.

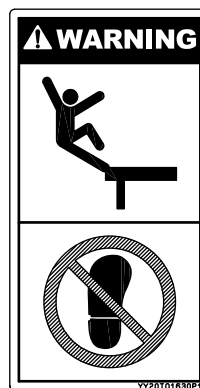

## 1.2 PRE-START SAFETY



### READ THE OPERATOR'S MANUAL

Read, understand and follow the safety messages and instructions in this manual. If these safety messages are not followed, serious injury or death could occur.

### 1.2.1 OPERATION RULES

#### ALWAYS OBSERVE BASIC SAFETY RULES AND PRECAUTIONS

All operators are required to receive training before operating this machine.

If a license or other special qualification is required to operate a hydraulic excavator in the country where this machine will be operated, all operators of this machine must meet those requirements and have a valid (not expired) license or qualification.

- Follow all safety precautions and procedures described in this manual while operating, inspecting and maintaining this machine.
- Never operate this machine if you are under the influence of drugs or medicines (including those which may make you drowsy) or alcohol. If you are not alert, do not operate the machine.
- To prevent accidents, confirm all working procedures before starting work. If a signal person is needed, always agree on the hand signals and designate a signal person before starting work.  
All personnel must know and understand all the signals. The operator shall respond to signals only from the appointed signal person, but shall obey a stop signal from anyone at any time. The signal person must stand in a clearly visible location when giving the signals.

#### ENSURE WORKSITE SAFETY

Understand your task and the potential hazards:

- Before operation, conduct a risk assessment with the site manager and confirm that all necessary safety precautions have been taken for the task. Always ask the site manager if there are any additional safety precautions or regulations for the task.

Know your working area:

- Visually survey the area around the working site before operating the machine.  
Look for mud or other soft ground that could cause the machine to become stuck or unstable when operating the machine. The ground near cliffs, trenches and road shoulders may be too soft to operate the machine. Be aware that rain, blasting activities, earthquakes, or other events may cause the ground be soft. Use signs to identify soft shoulders and soft ground. If needed, use a signal person.
- Choose operating locations where landslide will not occur or where falling rocks or building debris will not land on the machine.
- Set up barricades to prevent unauthorized personnel and/or machines from entering the working site.
- If working near a road, use a signal person and signs to alert vehicles and pedestrians of potential hazards and falling objects.

#### KEEP AWAY OTHER PEOPLE FROM THE MACHINE AND ATTACHMENT / EQUIPMENT DURING OPERATION

To prevent serious injury or death:

- Never allow anyone to stand on the machine, including the attachment /equipment and the upper structure, when operating.
- Never allow anyone to stand or to ride on a suspended load or the attachment/equipment.

## [1. SAFETY INSTRUCTIONS]

---

### 1.2.2 PROTECTION TOOLS

#### PERSONAL PROTECTIVE EQUIPMENT

Wear fitted clothing and protective gears.

- Wear clothing not exposing your skin a lot.
- Always change any clothing that has become contaminated with oil, fuel or other flammable substances.
- Do not wear loose fitting clothing, jewelry or any accessory and restrain long hair that can get caught in moving parts or that can catch on controls and result in unintended movement of the machine or the attachment /equipment.
- Always wear the proper personal protective equipment for the task you will be performing. This may include a hard hat, safety shoes, safety glasses, face shield, respirator, and/or a reflective vest. Consult with your supervisor to confirm you have the proper personal protective equipment for the task.
- Use ear protection when operating in noisy areas. Prolonged exposure to loud noises can cause hearing damage and even total hearing loss.
- Inspect all personal protective equipment for damage prior to use. If any personal protective equipment is damaged, or past its expiration date, do not use the equipment and contact your supervisor to obtain a replacement before operating machine.
- Other personnel working in the vicinity of the machine, including the signal person, should also wear the proper personal protective equipment appropriate for the worksite and for the task. This may include a hard hat, safety shoes, safety glasses, face shield, respirator, gloves, ear protection, and/or a reflective vest. Consult with your supervisor to confirm that personnel working in the vicinity of the machine have the proper personal protective equipment for the worksite and the task.

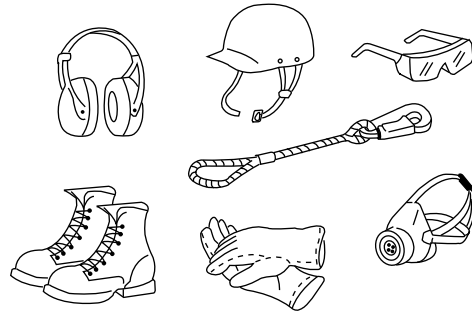

#### PREPARE FOR EMERGENCY

In case of emergency, know where the fire extinguishers (type: ABC, ABE) and the first aid kit are located.

- Know how to use a fire extinguisher.
- Inspect and maintain the fire extinguishers in compliance with your local/national regulations.
- Determine what emergency communication devices are necessary for your location and have a list of important telephone numbers available.
- Periodically inspect the first aid kit. Replenish items and replace expired items as necessary.

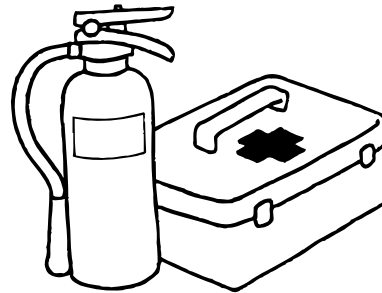

## 1.2.3 ABNORMAL AND EMERGENCY CONDITION

### WHEN A FAILURE IS FOUND

When operating, inspecting or maintaining the machine, if there is an unusual noise, vibration, smell, instrument malfunction, smoke, oil leak, a warning light illuminates or a warning is on the multi-display, do not continue to operate the machine.

- Always park on a firm, level location, lower the attachment to the ground, stop the engine, pull the control lock lever to the locked position, and remove the key.
- Contact your supervisor.
- Contact your KOBELCO authorized dealer for repair.

### EMERGENCY ESCAPE FROM THE CAB

If the normal operator's exit is blocked in an emergency, stop the engine, use the life hammer to break a window, and exit the cab. See "EMERGENCY ESCAPE FROM OPERATOR'S STATION" in Chapter 2.

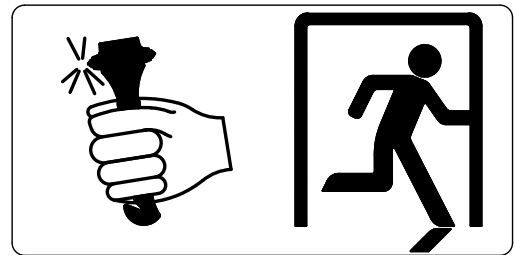

### IN THE EVENT OF A FIRE OR OTHER EMERGENCY

- Stop the engine.
- Use hand rails and steps to dismount machine. Do not jump from machine.

### IN THE EVENT OF A THUNDERSTORM

- Lower the attachment to the ground and if possible anchor the digging tool into the soil.
- Leave the cab and move away from the machine before the storm break out. Otherwise, you must stop the excavator, turn off the radio and keep inside the closed cab until the end of the storm.

## 1.2.4 POTENTIAL HAZARDS WHEN OPERATING

### PAY ATTENTION TO FALLING MATERIALS AND FLYING DEBRIS

Be sure to install the top guard and the front guard (option) when performing demolition works or works in the working sites (including mining and quarry sites) in which falling materials and/or flying debris can be generated .

- If working with the hydraulic breaker or other attachments, be sure to install front guard.
- When performing work that may result in falling material and flying debris, keep people a safe distance away from the work area.
- Always close the front window and doors before operating.

As for installing the front guard (option), contact your KOBELCO authorized dealer.

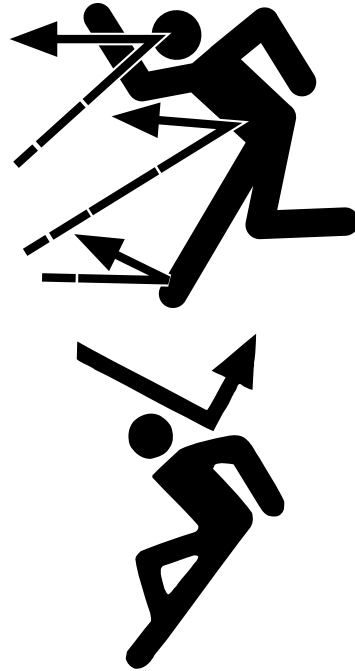

### CHECK PROTECTIVE RELATED GUARDS AND EQUIPMENT

- Check all protective related guards, covers, windows and mirrors are not damaged and secure prior to operation. If any damage or other issue is found, do not use the machine until the protective related parts and equipment has been replaced. Never attempt to repair protective related parts and equipment.
- Understand how the protective systems and the protective related equipment protects you as the operator and others around the machine.
- Never remove protective related parts and equipment from the machine.

### LIMITED PROTECTION FROM OBJECTS FALLING ON THE CAB

When operating near areas where landslides may occur or where rocks or other debris may fall, be aware that the cab and the guards installed provide limited protection for the operator and may not prevent serious injury or death.

- The top guard is designed according to ISO10262 and should not allow loads up to 227 kg (500 lbs.) dropped from a height of 5.22 m (17 ft.) to penetrate the cab. During building demolition or other activities, the load, the distance of the drop, or both could produce forces that exceed the limits of the top guard and cause serious injury or death.
- Never weld, drill or modify the top guard or other protective structures. Any modification could weaken the structural integrity of these protective structures, resulting in serious injury or death in case of collision, falling objects or landslides.
- Do not install any cab lifting device to the top guard or other protective structures.
- If an accident occurs, do not try to straighten or repair the top guard or other protective structures. Contact your KOBELCO authorized dealer for functional verification or replacement of any of the protective structures.

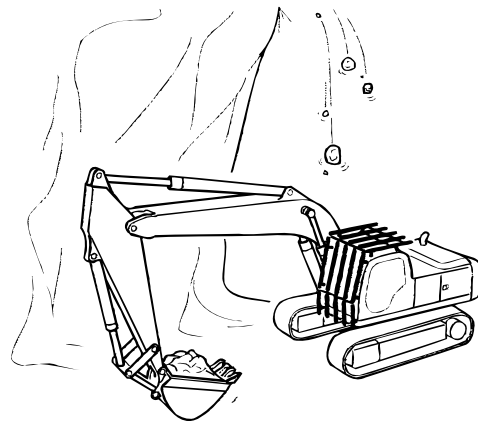



## GROUND CONDITIONS

Always place tracks perpendicular (at a 90 degree angle) to the edge of a cliff or the road shoulder with the travel motors(1) positioned away from the edge to prevent the machine from falling over the edge.

Visually inspect for soft ground near the edge, especially either any raised ground or any wet ground following a rain.

Do not dig close to the machine or undercut the bank in front of the machine to prevent the machine from falling over the edge.

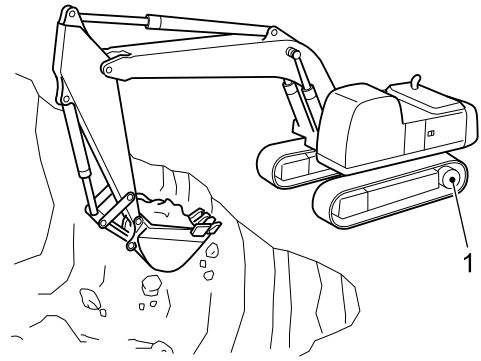

## ELECTRICAL POWER LINES

Keep a safe distance from electrical power lines. Never approach power lines with any part of the machine and its load unless all local and national required safety precautions have been taken. Electrocutation and death can result from arcing, touching or even being close to a machine that is in contact with or near an electrical source.

- Maintain the maximum possible distance from power lines and never violate the minimum clearance.
- Always contact the nearest electric utility and determine jointly what specific precautions must be taken to ensure safety.
- Consider all lines to be power lines and treat all power lines as energized even though it is known or believed that the power is shut off and the line is visibly grounded.
- Use a signal person to observe the approach of any part of the machine or load to the power line.
- Caution all ground personnel to stand clear of the machine and the load at all times.
- If the machine should come in contact with a live electrical source, do not leave the operator's seat. Do not allow anyone to approach or touch the machine.
- Observe the applicable rules or regulations for clearance distances for power lines and other electrical equipment for the country where the machine is operating. Always maintain the following clearances when operating near high voltage power lines.

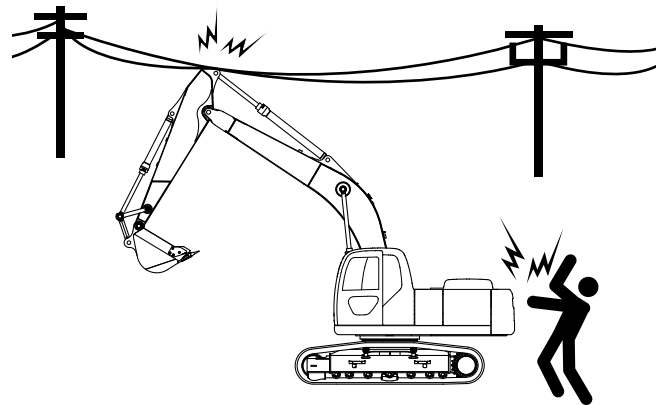

The reference of the safe distances from high voltage cables are as follows.

LINE VOLTAGE(V)	MINIMUM DISTANCE m(feet)
0 to 50,000	3.0(10) or more
50,000 to 200,000	4.5(15) or more
200,000 to 350,000	6.0(20) or more
350,000 to 500,000	7.5(25) or more
500,000 to 750,000	10.5(35) or more
750,000 to 1,000,000	13.5(45) or more

## USE WORK LIGHTS

- When operating in dark locations, turn on the work light. If necessary, use additional lighting devices to make the work areas bright enough to operate.
- Stop work if you have poor or limited visibility because of darkness, fog, rain, especially lightning, snow, or other causes.

## [1. SAFETY INSTRUCTIONS]

---

### OPERATING ON SOFT GROUND

When working on soft or wet ground, place logs or lumber horizontally beneath the crawler tracks to prevent the machine from becoming stuck.

Be aware frozen ground may become soft or wet as the ambient temperature rises during the day and could cause the machine to become unstable or stuck.

### VISUALLY INSPECT GROUND CONDITIONS BEFORE OPERATING

The ground near cliffs, trenches and road shoulders may be too soft to operate the machine. Visually inspect for soft ground before travelling or working in these areas. Be aware that rain, blasting activities, earthquakes, or other events may cause the ground to be soft.

To prevent serious injury, death, and property damage, only travel or work on firm ground when the machine is close to sudden elevation changes, including cliffs, trenches and road shoulders. The weight of the machine or vibration from the machine may cause the ground to collapse and cause the machine to tip or roll over.

## 1.2.5 FIRE PREVENTION

### FIRE CAUSED BY FLAMMABLE SUBSTANCES

Fuel, oil, electrolyte, windshield washer fluid and other chemicals are flammable.

To prevent serious injury or death from possible fire:

- Remove flammables such as leaves, wooden debris, paper waste, etc. from the areas of exhaust manifold, muffler, battery, and undercover, etc.
- Do not smoke or bring other ignition sources near areas where flammables are stored and/or handled.
- Refuel only after stopping the engine.
- Do not leave the machine when refueling or when refilling with oil.
- Try not to spill fuel on heated surfaces or on electrical parts. Clean any spills immediately.
- After refueling or refilling with oil, securely tighten the fuel and the oil caps and clean up any spills immediately.
- Store fuel and oil in designated areas and restrict access to only authorized personnel.
- Remove all flammable materials in the area before performing grinding or welding work.
- Do not weld or perform gas cutting on pipes and tubes which contain combustible liquids.
- Only use nonflammable oils to wash parts. Do not use flammable oils, such as diesel fuel or gasoline, to wash parts.



### FIRE CAUSED BY THE ELECTRIC SYSTEM

Short-circuits in the electrical system may cause fire.

- Check all wiring harness connections are clean and secure.
- Inspect wiring harnesses, connectors, and clamps periodically. Repair, replace, or tighten connectors and clamps if any damage or loose connections are found.

### FIRE CAUSED BY LEAK

Check all clamps, guards, protective cushions for the hoses and the tubes are secure.

During operation, machine vibration may cause loose hoses or loose tubes to be damaged from contact with other parts and leak high pressure oil or other fluids and result in a fire and serious injury or death.

If any issue is found, immediately tighten, repair or replace it.

Do not operate machine with damaged or bent hoses or tubes.

### USE ANTI-EXPLOSION WORK LIGHTS

Use only work lights with anti-explosion specification to prevent serious injury or death.

Lighting must meet the requirements for areas where explosive concentrations of vapors and dusts could exist to prevent a fire or explosion when performing inspection and maintenance activities.

## 1.2.6 GETTING ON AND OFF THE MACHINE

### PRECAUTIONS OF GETTING ON AND OFF THE MACHINE

To prevent serious injury or death:

- Clean all slippery substances such as grease, oil, mud, ice, and others attached to the steps and handrails.
- Inspect the steps and handrails for damage or loose parts. Replace any damaged parts and tighten any loose bolts or nuts.
- Always use the steps and handrails to get on and off the machine.
- Always face the machine and maintain three points of contact with the steps and handrails.
- Do not use the control lock lever and control levers as hand holds.
- Do not have anything in your hands, including tools, when getting on and off the machine.
- Never jump on and off the machine or attempt to get on or off a moving machine.

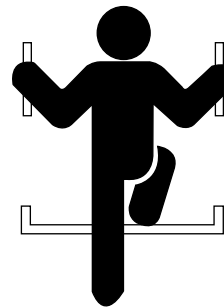
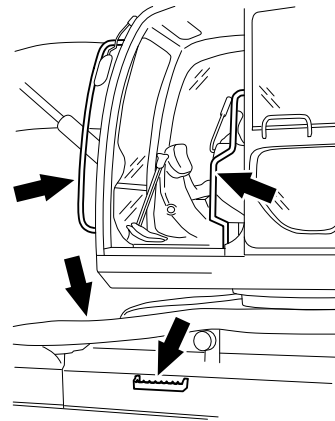

## 1.2.7 PRE-START UP INSPECTION ON THE MACHINE

Always perform a pre-startup inspection before operating this machine to check for any potential issues. For more information, refer to "EVERYDAY CHECK-UP" in Chapter 3 in the standard operation & maintenance manual.

### ATTACH A "DO NOT OPERATE" TAG

To prevent serious injury or death, never allow unauthorized personnel to start the engine or touch the control levers during inspection and maintenance activities. Always lower the attachment, pull the control lock lever to the locked(up) position, stop the engine, and remove the key before performing inspection and maintenance.

Use a temporary hang tag to communicate that the machine is out of service. You may need to use more than one temporary hang tag depending on the inspection and maintenance activities to be performed.

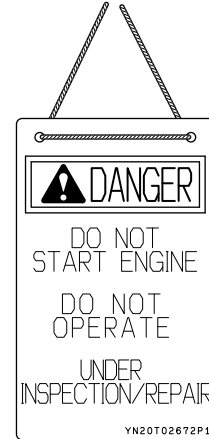

### CHECK THE MACHINE LOG BOOK

Check machine log book to check that periodic maintenance and inspections have been performed and all necessary repairs made.

### ALWAYS KEEP THE MACHINE CLEAN

Always keep the machine clean and free of scattered debris, and spilled lubricant and oil.

If electrical components or systems get wet, then equipment malfunction, short circuit, or fire may result in serious injury or death.

Never use pressurized water or steam to clean inside the operator cab or any electrical components, such as sensors and connectors.

Also never wash the vent hole of covers or guards with high-pressure cleaning machine.

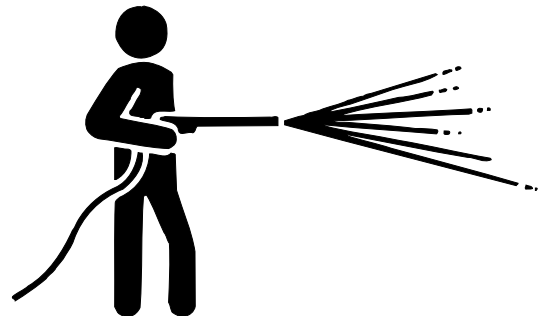

### KEEP INSIDE OF OPERATOR CAB CLEAN

- To prevent slippery pedals, always remove mud, grease, oil, and other substances from the soles of your shoes before entering the cab.
- Secure parts and tools inside the cab before operating.

To prevent fire:

- Do not bring explosive or flammable materials into the cab.
- Do not leave your cigarette lighter inside the cab.  
If the cab temperature becomes too hot, the lighter may explode.
- After smoking, always put out your cigarette.
- Do not leave plastic bottles inside the cab or attach suction cups to the windows.  
These items may act as lenses and could start a fire.

## [1. SAFETY INSTRUCTIONS]

---

### SEAT BELT INSPECTION

Check if seatbelt is cut or frayed and check if mounting hardware is damaged or loose before fastening the seatbelt. If an issue is found with the seatbelt or the mounting hardware, do not use machine until the issue has been repaired.

Replace seatbelts every 3 (three) years or more frequently if damaged or frayed.

## 1.3 SECURE VISIBILITY



### READ THE OPERATOR'S MANUAL

Read, understand and follow the safety messages and instructions in this manual. If these safety messages are not followed, serious injury or death could occur.

### 1.3.1 BE AWARE OF YOUR SURROUNDINGS

When operating or traveling in the machine, the operator may not observe people and obstacles near the machine. To prevent serious injury, death or damage to the machine.

- Keep windows clean.
- Replace cracked or broken glass.
- Adjust the mirrors for maximum visibility around the machine before operating. If needed, clean the mirrors.
- If the machine is equipped with the rearview camera and the side cameras, clean the lenses to display clear images from the rearview and side cameras to the monitor.
- Move the attachment /equipment as needed to improve visibility of the right side during machine travel.
- There are blind areas in the mirror and camera views. Confirm for safety around the machine before operating the machine.
- If needed, use a signal person. The operator should always be alert and follow the signals from the signal person. The operator shall respond to signals only from the appointed signal person, but shall obey a stop signal from anyone at any time.
- When operating in dark locations, turn on the work light. Additional lighting may be needed to illuminate the work area.
- Stop work if you have poor or limited visibility because of darkness, fog, rain, especially lightning, snow, or other causes.
- Never attach mirrors or other articles to the handrails. Over time, excessive vibration may weaken the handrail and cause it to fail.
- Do not operate the machine without the monitor pictures of the rearview camera and the side camera being displayed.
- Do not remove or disassemble the rearview camera and the side camera systems.  
The camera systems are installed on the base machine according to ISO 16001:2017. When removal or disassembly of them is required, contact your KOBELCO authorized dealer otherwise it may void the machine warranty provided with the machine.

#### MIRROR AND CAMERA LOCATION

Only use genuine KOBELCO mirrors, rearview camera system, and side camera system.

Regarding adjustment of the mirrors, the rearview and side cameras, see "ADJUSTMENT OF MIRRORS" in Chapter 3.

## 1.4 PRECAUTIONS FOR OPERATION



### READ THE OPERATOR'S MANUAL

Read, understand and follow the safety messages and instructions in this manual. If these safety messages are not followed, serious injury or death could occur.

### 1.4.1 STARTING

#### CHECK A "DO NOT OPERATE" TAG

Before starting the engine, check display of warning tags.

If warning tags are displayed, do not start the engine.

The warning tags are used to notify that the machine is in an inoperable condition.

Report this situation to a supervisor of the machine and do not start the engine until the warning tags are removed.



#### ONLY THE OPERATOR IS ALLOWED IN THE CAB

The operator is the only person that should be on or near the machine and in the cab. Do not allow any other personnel to be present in the cab or on the machine.

#### CHECK WORKING SITE AND SET UP BARRICADES

To prevent serious injury, death and property damage, before you start the engine and before you move the machine:

- Check that no one is on, under, and around the machine. Make sure that all personnel are clear of the machine and surrounding area.
- Check there are no other machines or obstacles in the area surrounding the machine.
- Set up barricades to prevent unauthorized personnel and / or machines from entering the working site.

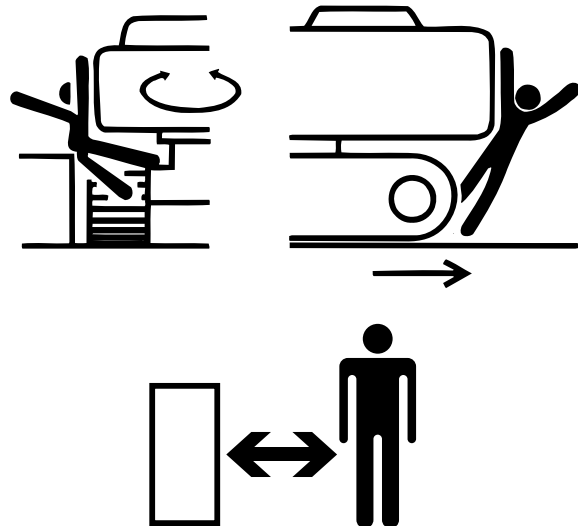

#### PRE-OPERATION SAFETY CHECK

To prevent serious injury or death, before operating:

- Close and lock the doors and windows.
- Close and lock the access panels and doors.
- Adjust mirrors for maximum visibility around the machine. See "ADJUSTMENT OF MIRRORS" in Chapter 3 for additional information.



## FASTEN YOUR SEATBELT

To prevent serious injury or death, always fasten your seatbelt before starting the machine and keep your seatbelt fastened during operation. Sit in operator's seat and adjust seat so you can properly operate all of the machine controls.

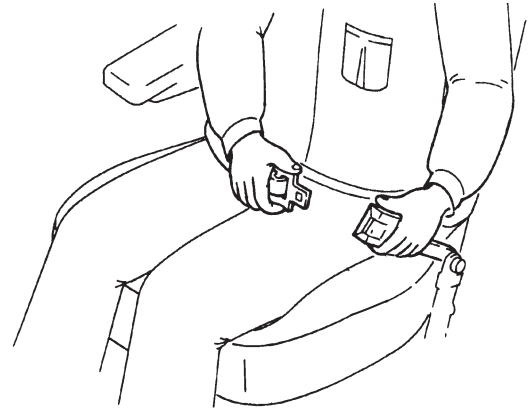

## BEFORE STARTING ENGINE

- Check the pilot control lock lever is in the "LOCKED" (up) position. If not locked, incidental contact with the control levers, pedals and other control devices may result in unexpected and unintended machine movement.
- Confirm that all control levers and pedals have returned to neutral.
- Sound horn to alert personnel near the machine.
- Always be seated in the operator's seat with your seatbelt fastened.

A: Locked Position

B: Unlocked Position

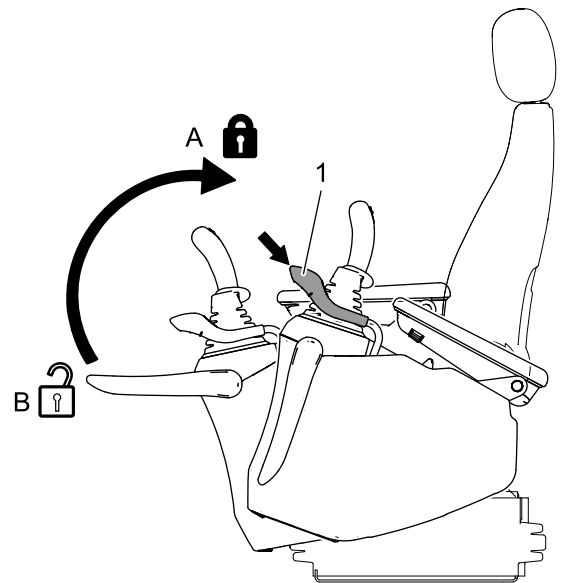

Only start the engine from the operator's seat. Never attempt to start the engine by connecting the starter terminals to the batteries.

Unexpected machine movement could result in serious injury, death, or damage to the machine and electrical system.

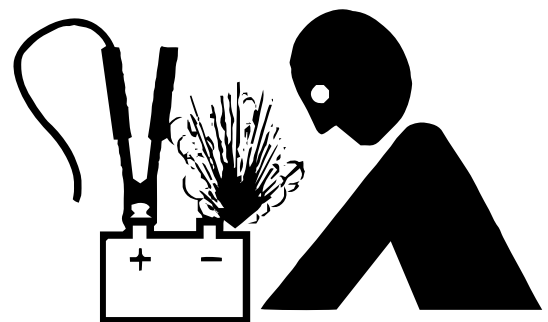

## WARM UP

To prevent serious injury or death, always allow the machine to warm up prior to operation, especially in cold weather. Do not start operation as soon as the engine is started. If not warmed up, there could be a delay between when the control levers are moved and when the machine or the attachment /equipment responds, resulting in unintended or unexpected movement of the machine or attachment /equipment.

After starting the engine, check all gauges indicate properly.

## [1. SAFETY INSTRUCTIONS]

---

### ATTACHMENT MODE SELECT SWITCH

Check the attachment installed matches the selected attachment mode and is appropriate for the task to be performed. If the attachment mode selected does not match the attachment, the machine will not work properly and it will result in serious injury, death, or property damage.

See "SWITCHING ATTACHMENT MODE" in Chapter 3 for additional information.

### CHECK CONTROL PATTERN BEFORE OPERATING

Before operation, always check the operation of each control lever and each pedal.

If the movement of the machine does not match selected control pattern which is shown on the card, stop the work and shut down the machine. The machine movement must match with the operating pattern.

If the machine movement does not match the card displayed in the cab, change the card so as to match the machine control pattern.

If any issue is found, do not operate machine until the issue had been corrected. If needed, contact your KOBELCO authorized dealer.

### CHECK WARNING DEVICES

Make sure that the horn, the travel alarm, the swing flashers and all other warning devices are warning properly.

### AVOID INTERFERENCE BETWEEN THE ATTACHMENT AND THE MACHINE

Check clearance between the attachment and the cab before starting operation because a certain kinds of attachment and a certain combination of the option and the machine may cause the contact of the attachment and the cab or some other parts of the machine.

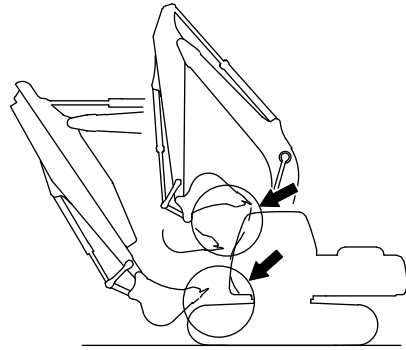

### PRECAUTIONS OF SWINGING / TRAVELING

- Always sound the horn before starting the engine, traveling the machine, or swinging the upper structure to alert people in the vicinity of the machine.
- Always operate at a safe distance from other machines or obstacles in the vicinity of the machine.
- Place a signal person at poor visibility area.

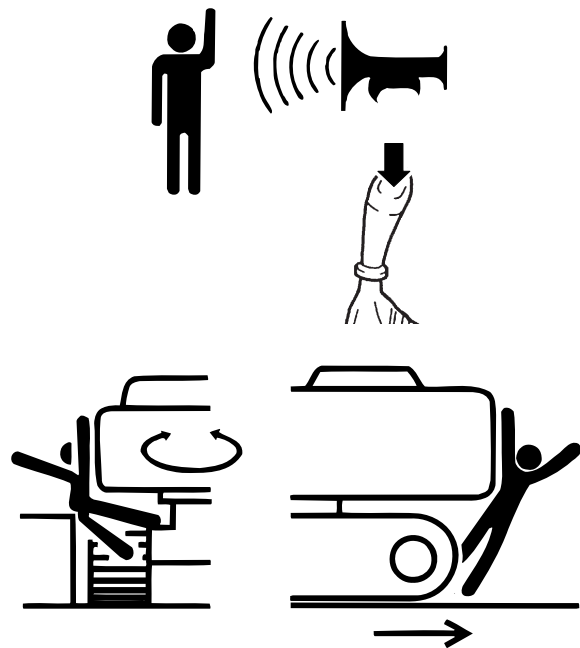

## WORKSITES IN URBAN AREAS

Set up barricades to prevent unauthorized personnel and/or vehicles from entering the worksite. If working near a road, use a signal person and signs to alert vehicles and pedestrians of potential hazards and falling objects. If needed, use a signal person to direct traffic. The operator should always be alert and follow the signals from the signal person. The operator shall respond to signals only from the appointed signal person, but shall obey a stop signal from anyone at any time.

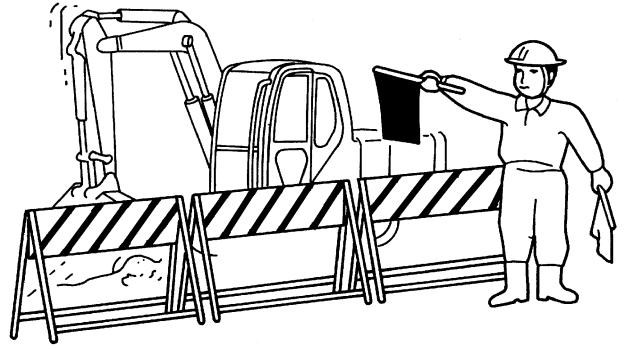

## 1.4.2 TRAVELING

### ALWAYS CONFIRM DIRECTION OF TRAVEL

Before moving the machine, check the position of the undercarriage (tracks). The normal travel position is for the idler wheels(1) to the front under the cab and the drive sprockets(2) to the rear.

When the undercarriage (tracks) is reversed, the travel controls operate in the opposite directions compared to when the idler wheels(1) are in the front. Move the travel levers slowly and travel at a low speed.

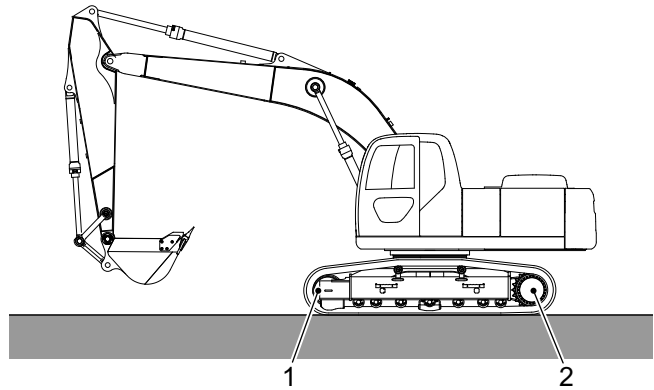

### MOVE TRAVEL LEVERS IN A SLOW AND DELIBERATE MANNER

- Gradually increase speed. Moving the travel levers quickly will cause the machine to accelerate quickly and result in a sudden start or sudden acceleration.
- Do not move the travel levers from forward to reverse or vice versa rapidly.
- Do not perform an abrupt pivot turn or spin turn.
- Do not stop quickly by releasing your grip on the levers during travel.

### PRECAUTIONS IN TRAVELING

Travel on a level and firm ground as much as possible.

- Move the attachment /equipment as needed to improve visibility of the right side during machine travel.
- Travel slowly on a rough terrain.
- Do not go over obstacles. When going over obstacles inevitably, go slowly with the attachment positioned close to the ground as much as possible. Because the machine may tip/roll over.

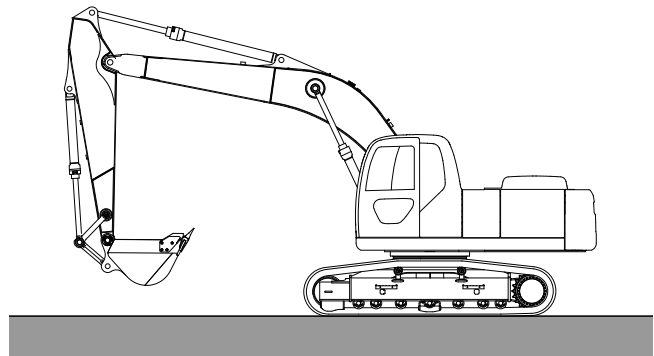

## TRAVELING ON SLOPES

Traveling up and down the slopes of 30 degrees or more is not allowed to avoid a risk of tipping/rolling over.

- Travel at a low speed when traveling up and down the slopes,
- When traveling up the slopes, extend the front attachment to the forward to avoid tipping/rolling over to the rearward.
- When traveling down the slopes, set the bucket in the position where it can reach the ground immediately to stop the machine.
- Travel carefully on grasses, fallen leaves, ice, and steel plates because the machine can slip easily.

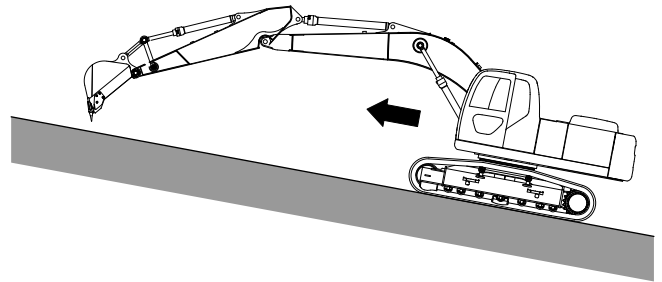

Traveling up slope

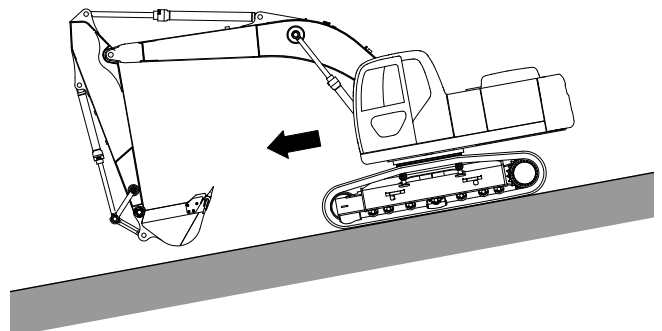

Traveling down slope

## PRECAUTION OF TRAVELING ON SLOPES

The machine could tip or roll over, slide, or skid when travelling across slopes.

Be sure to travel off the slope, travel along flat area, then travel onto the slope at the desired location.

Never travel across the slopes.

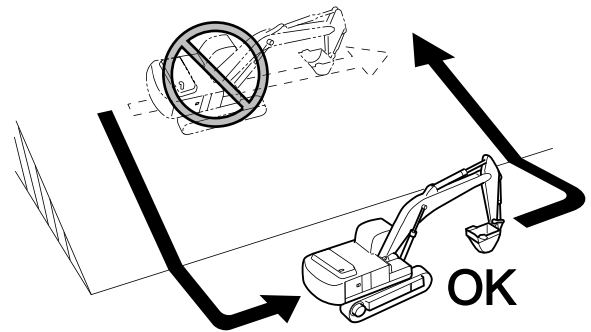

## TRAVELING ON FROZEN OR SNOW COVERED GROUND

Use extreme care when operating on frozen or snow covered ground.

- The ground may be extremely slippery and the machine can slide or skid.
- Do not perform abrupt start, stop, or movements or the machine could become unstable and tip or roll over.
- Snow can make elevation changes (e.g., road shoulders or steep banks) hard to perceive.
- Snow can cover obstacles or obstructions and make them difficult to recognize.
- During the day as ambient temperatures rise, frozen ground may thaw and become soft and cause the machine to become unstable or stuck.

## [1. SAFETY INSTRUCTIONS]

---

### TRAVEL ON WET OR LOW TRACTION SURFACES

Use caution when travelling on an incline over wet surfaces, including wood, steel, and piles of wet leaves and branches. The machine could slide or skid and result in serious injury, death or property damage.

### DOZER COLLISION

Be careful not to strike the dozer against large rocks, etc. It may cause a premature damage of the dozer or the cylinder.



### OFFSET LOAD OF DOZER

If the machine is supported by the dozer, be sure to ground the dozer bottom evenly, avoiding an offset or concentrated load.

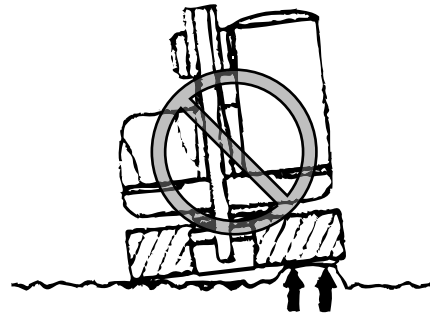

### 1.4.3 PROHIBITED OPERATIONS

Always follow the procedures in this manual when operating this machine. Abuse and misuse may result in serious injury, death, and property damage and reduce the life of the machine. Never attempt the following under any circumstances.

#### NEVER USE THE SWING POWER TO PERFORM WORK

Never apply swinging force (slewing force) to rock sliding work and side wall breaking work.

If the swing power is used to perform work, excessive force may be exerted on the machine and the attachment /equipment resulting in damage to the machine and the attachment /equipment and may reduce the life of the swing system.

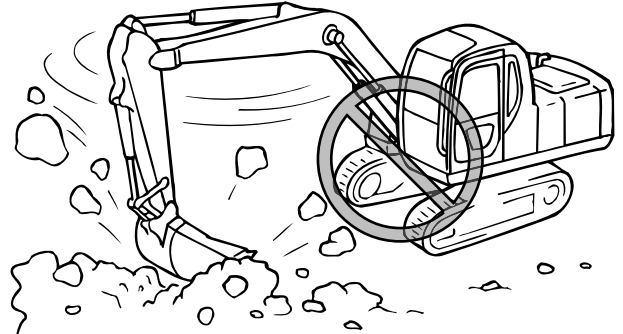

#### NEVER USE THE TRAVEL POWER TO PERFORM WORK

Do not use the travel power to perform digging or leveling work with the attachment in contact with the ground.

If the travel power is used to perform work, excessive force may be exerted on the machine and the attachment /equipment resulting in damage to the machine and the attachment /equipment.

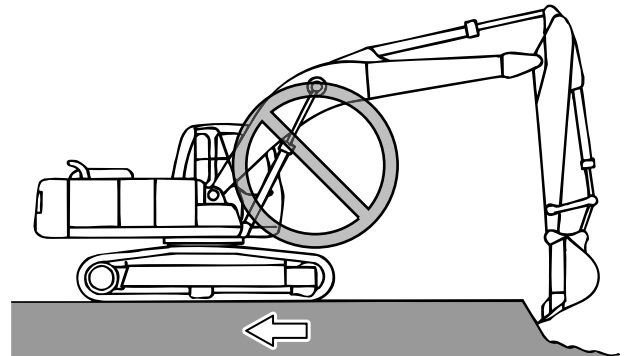

#### DO NOT PERFORM "HAMMERING" OPERATIONS WITH THE BUCKET

Never use the bucket for hammering and piling. It will cause severe damage to the machine and its components.

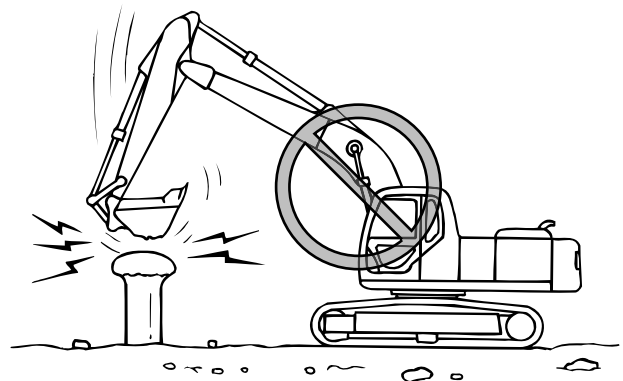

## [1. SAFETY INSTRUCTIONS]

---

### DO NOT USE MACHINE WEIGHT FOR DIGGING OPERATION

Do not use the machine weight to obtain power to dig. This could cause severe damage to the machine and its components.

Before digging the hard bedrock, crack the hard bedrock into pieces by another method and then dig it. It will not damage the machine and result in more economical way.

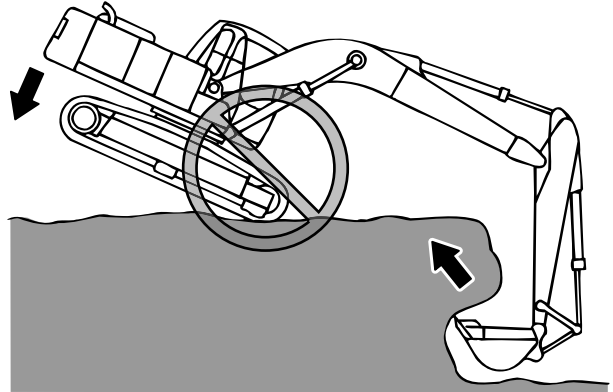

### OPERATING ON A SLOPE

Use extreme caution when operating machine on a slope. The machine may become unstable and could tip or roll over.

- Place the crawlers parallel to the slope.
- Always swing the upper structure slowly when rotating it toward the downhill side with a load. The extra weight from the load may make the machine unstable.
- Be aware the weight of the upper structure could cause it to rotate when the machine stops on a slope.
- When the machine stops on the slope, lower the attachment to the ground on the downhill side of the machine and wedge the bucket into the ground if equipped.

### CALL BEFORE YOU DIG

Confirm the local government or the public service company for locations of underground utilities of gas, water, phone, electrical power, and so forth before working in the area seemingly with these lines. Always inspect the worksite for evidence of unmarked utilities and piping and contact others if necessary.

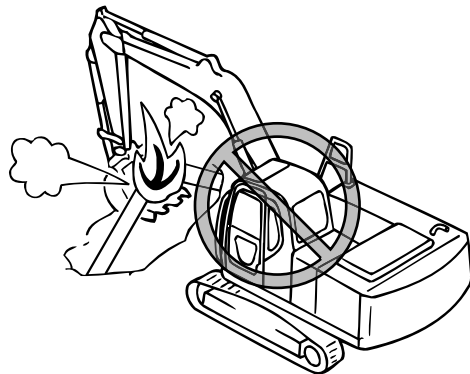

### LIMITED MOVEMENT IN WORK AREA

Use extreme caution when working in areas that constrain or limit the movements of the machine, including tunnels, bridges, around electrical power lines, or inside structures, to prevent the machine or the attachment /equipment from contacting these obstacles during operation.

To prevent serious injury, death or property damage, always use a signal person to assist the operator with maneuvering in these areas and keep the machine and the attachment /equipment a safe distance from these obstacles.

The operator should always be alert and follow the signals from the signal person. The operator shall respond to signals only from the appointed signal person, but shall obey a stop signal from anyone at any time.

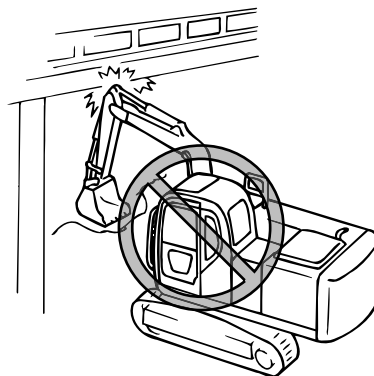



### OPERATING UNDER CLIFF OR OVERHANG

Never undercut or dig beneath a cliff or overhang. It can cause rocks and debris to fall.

Be aware that the cab guard installed provide limited protection for the operator and may not prevent serious injury or death.

The cab top guard was designed conforming to ISO10262 and should not allow every possible loads to penetrate the cab.

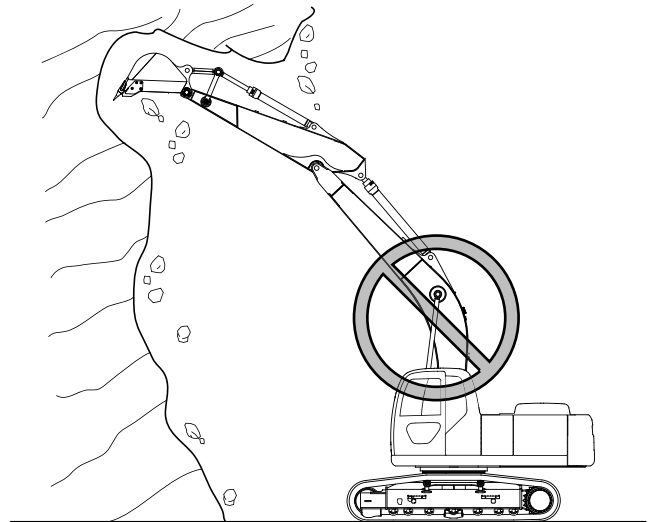

1

### DEEP EXCAVATION OPERATION

To prevent damage to the machine, during deep excavation or diagonal digging.

- Do not allow the arm or the hydraulic piping to contact the side of the trench or hole.
- Do not allow the arm to contact the crawler shoe when operating with the arm below horizontal.

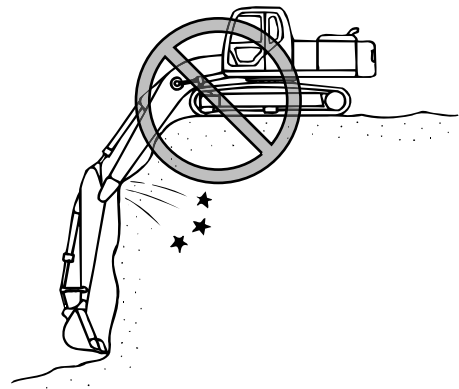

### PAY ATTENTION TO INTERFERENCE OF DOZER

When operating the machine with the dozer positioned at the front side, it can cause the dozer to contact the boom cylinder or the bucket. So pay attention to it.



## [1. SAFETY INSTRUCTIONS]

---

### DO NOT LIFT OR MOVE PERSONNEL

Never lift or move personnel by using the attachment.  
The lifted personnel may fall off, causing severe accidents.



### DO NOT LIFT UP THE MACHINE WITH ARM CYLINDER STROKE END

Never lift up the machine with arm cylinder stroke end. It may cause damage to the equipment/attachment and cylinder.

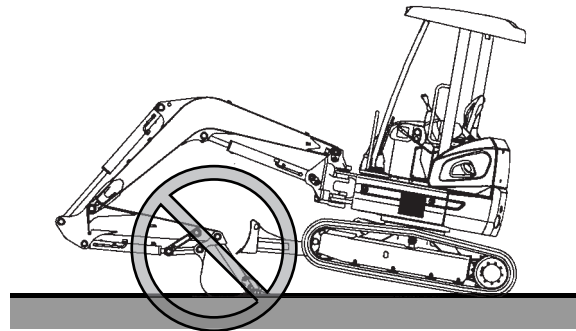

### BUCKET/ARM IN OPERATION WITH DOZER POSITIONED AT FRONT

Be careful not to hit the dozer with the bucket when operating arm in or bucket in with the travel/transport position.



### NO PERSONNEL ALLOWED UNDER THE BUCKET OR ATTACHMENT / EQUIPMENT

Never move a suspended load or the bucket over a person or above the driver's cab of a truck.  
The load could fall and cause serious injury or death.



## REMOVING DIRT OF BUCKET

With the bucket in the retracted position, do not give impact on the bucket to remove soil. It may cause damage to the equipment/attachment and cylinders.

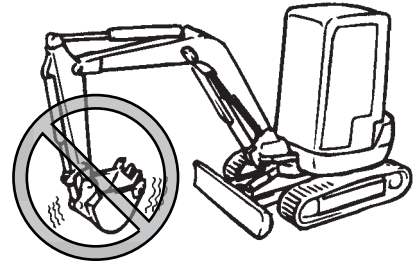

## LIFTING WORK

This machine is designed for the application of digging, loading, and leveling using the bucket.

Furthermore, some machines are designed in consideration of works with a breaker, crusher, or others installed.

When lifting a load by using this machine, observe the laws and others of the country or area in which this machine is to be used.

Even though lifting with this machine is allowed according to the laws of the country or area in which this machine is to be used, do not lift the load by using the teeth of the bucket, the breaker, the crusher, or others. It can cause the lifting tools to come off and result in falling off of the load, leading to serious accidents or death.

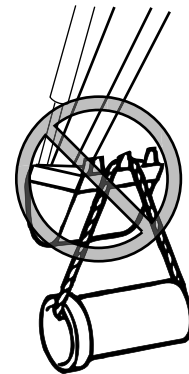

## DO NOT OPERATE THE CYLINDERS TO THE STROKE END

Operate the bucket, boom and arm cylinders to leave some clearances (A) to the both stroke ends. If the cylinder is operated to the stroke end, it will generate an excessive load and cause damage to not only the cylinder but also the pin, boom and arm.

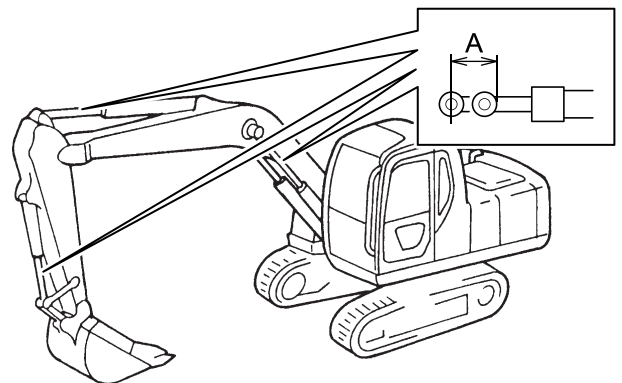

## DO NOT OPERATE IN ENCLOSED SPACES

Do not operate the machine in enclosed spaces or, in any case, without appropriate ventilation.

## PRECAUTIONS FOR POTENTIALLY EXPLOSIVE ENVIRONMENT

When using the machine in a potentially explosive environment, comply with local codes and regulations of each country.

## [1. SAFETY INSTRUCTIONS]

---

### PRECAUTIONS FOR LEAVING THE OPERATOR'S SEAT

Do not leave the machine with the engine running.

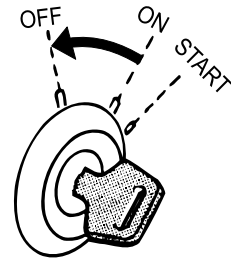

### 1.4.4 SAFETY CHECK ON THE PARKING MACHINE

There are risks of creeping, unexpected movement at the time of coming start if the machine is not parked properly. Park the machine following the safety parking procedures shown below.

#### ALWAYS PARK MACHINE PROPERLY

1. Travel machine to a safe location on firm, level ground.
2. Lower the attachment to the ground.  
If equipped with a dozer blade, lower it to the ground.
3. Set the auto acceleration switch to the "OFF" position.

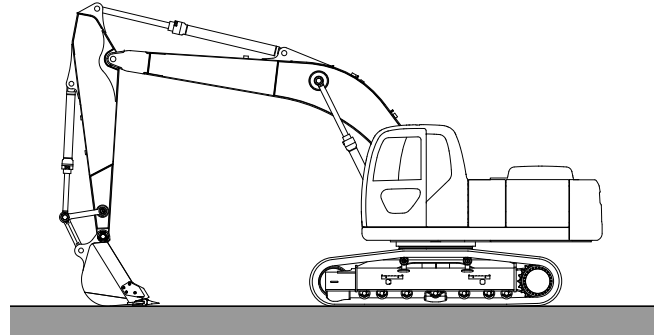

4. Pull the control lock lever(1) to the locked(up) position(A).  
If not locked, accidental or unintended contact with the control levers, pedals and other control devices may result in unexpected and unintended machine movement.
5. Turn engine throttle to the low idle position.
6. Turn the starter switch to the "OFF" position and remove the key.  
Close and lock the windows and the cab door.  
Check the windows, doors and all other machine access covers are locked and secured.

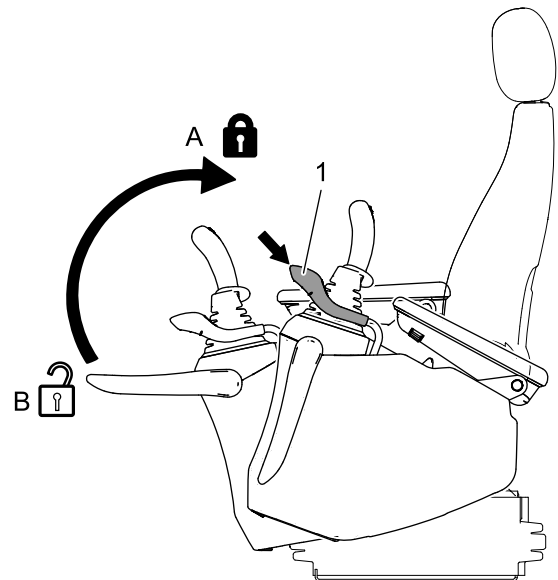

## [1. SAFETY INSTRUCTIONS]

---

### PARKING MACHINE ON SLOPE

If the machine must be parked on a slope.

1. The undercarriage and the upper structure and the attachment /equipment must face downhill.
2. Lower the attachment into the ground. If equipped with a bucket, wedge the bucket into the ground. If equipped with a dozer blade, lower it to the ground.
3. Set the auto acceleration switch to the "OFF" position.

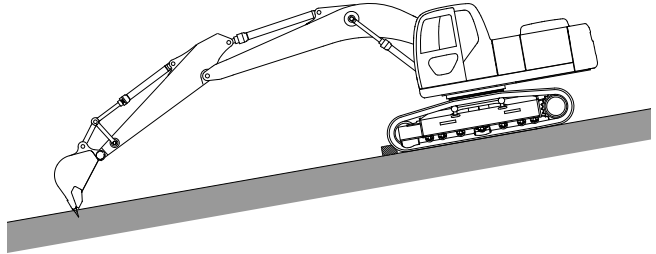

4. Pull the control lock lever(1) to the locked(up) position(A).  
If not locked, accidental or unintended contact with the control levers, pedals and other control devices may result in unexpected and unintended machine movement.
5. Turn engine throttle to the low idle position.
6. Turn the starter switch to the "OFF" position and remove the key.  
Close and lock the windows and the cab door.  
Check the windows, doors and all other machine access covers are locked and secure.
7. Block the tracks in the front and the rear.

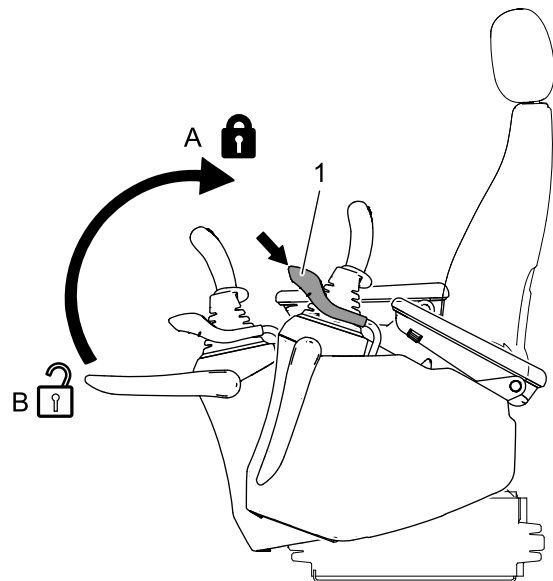

## 1.5 AT THE END OF EACH SHIFT



### READ THE OPERATOR'S MANUAL

Read, understand and follow the safety messages and instructions in this manual. If these safety messages are not followed, serious injury or death could occur.

Always make sure the machine is secure and ready to be used for the next shift or moved to another job site.

1. Park the machine on a firm, level ground.
2. Lower attachment to the ground.

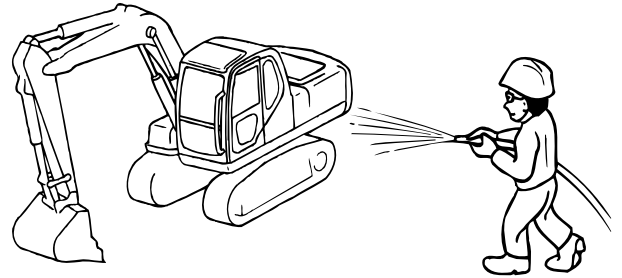

3. Pull the control lock lever(1) to the locked(up) position(A) and check all control levers and pedals have returned to neutral.
4. Close and secure all windows in place to prevent water or moisture from damaging any electrical components.
5. Remove the key from the key switch and lock all doors and access panels.
6. Refill the fuel tank to the full mark to reduce air volume and condensation (moisture). This will decrease the possibility of freezing in the fuel tank, rusting due to moisture and other potential issues.
7. Thoroughly clean and inspect the machine. If any issues are found, always lubricate, repair, or replace any machine parts and systems prior to restarting the machine. As needed, contact your KOBELCO authorized dealer.
8. If the machine is stored in cold climates, it may be necessary to remove the batteries from the machine and store them in a warm, well ventilated area. Re-install the batteries before the next start up. This helps prevent premature battery deterioration.

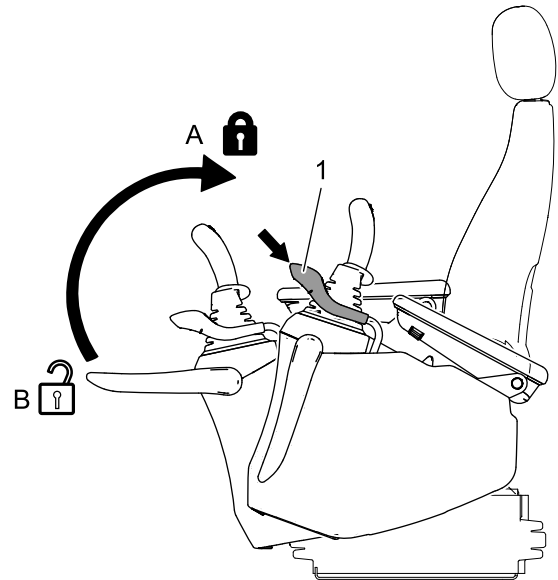

## 1.6 PRECAUTIONS OF INSPECTION & MAINTENANCE

---



### READ THE OPERATOR'S MANUAL

Read, understand and follow the safety messages and instructions in this manual. If these safety messages are not followed, serious injury or death could occur.

---

### 1.6.1 PERIODIC INSPECTIONS

- Every year, the machine should be inspected by a qualified inspector or a registered inspection agency. If needed, contact your KOBELCO authorized dealer for that inspection.
- Every month inspect the machine for the following.

See chapter 4. "INSPECTION AND MAINTENANCE" for additional information about the monthly inspection & maintenance requirements for your machine.

Always keep all maintenance and all inspection records, including both the monthly and the yearly inspections, according to local codes and regulations of your country.



## 1.6.2 BEFORE INSPECTION & MAINTENANCE

### READ OPERATION/MAINTENANCE PROCEDURES CAREFULLY

Improper maintenance could cause serious injury (crush or burn) and damage the machine. Read and understand the maintenance procedures (preparation for safe work, proper tools, qualifications, important parts, supervisor designation and wear the appropriate personal protective equipment, etc.) described in the manuals before safely and carefully inspecting and performing maintenance on the machine.

### CONFIRM JOB PROCEDURES

To prevent accidents, confirm all work procedures before starting.

### USE A SIGNAL PERSON AND A FLAGMAN

Know and use the hand signals required for particular jobs and confirm who has the responsibility for signaling: All personnel must know and understand all the signals.

The operator shall respond to signals only from the appointed signal person, but shall obey a stop signal from anyone at any time.

The signal person must stand in a clearly visible location when giving the signals.

### ORGANIZE AND CLEAN UP WORK SITE

Inspecting and maintaining the machine at a messy working site may cause personal injury.

Clear obstacles, grease, oil, paint, debris, etc., from the work site.

### ATTACH A "DO NOT OPERATE" TAG

To prevent serious injury or death:

- Never allow unauthorized personnel to start the engine or touch the control levers during inspection and maintenance activities.
- Always lower the attachment, pull the control lock lever to the locked(up) position, stop the engine, and remove the key before performing maintenance.
- Use a temporary "DO NOT OPERATE" hang tag to communicate that the machine is out of service. You may need to use more than one temporary hang tag depending on the work to be performed.
- Always have an operator at the controls to shut down the machine if the machine needs to be running for maintenance activities or an inspections. The operator and the maintenance personnel must have a means of communication when performing these tasks.

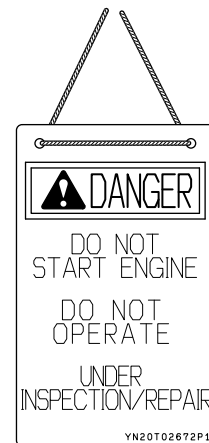

If any issues are found, always contact your KOBELCO authorized dealer before repairing or replacing any machine parts and systems prior to restarting the machine.

### USE PROPER TOOLS

To prevent serious injury or death, do not use of damaged tools or tools not intended for the task.

### 1.6.3 DURING INSPECTION & MAINTENANCE

#### STOP ENGINE BEFORE PERFORMING INSPECTION AND MAINTENANCE

Always stop the engine and allow the engine and other components to cool before performing inspection or maintenance activities. Do not touch engine components when the engine is running or immediately after it has stopped to prevent serious injury or death. There are many hazards that can cause harm, including rotating parts, high voltage, high pressure fluids, and high temperature.

#### HOT FLUIDS

To prevent burn injuries.

- Do not remove the radiator cap immediately after stopping operation. Hot radiator fluid may cause burns. Wait until the radiator cap is cool to the touch, then slowly loosen to release the internal pressure. Then remove the cap.
- Do not remove the oil cap or plug immediately after stopping operation. Hot oil may cause burns. Wait until the oil cap or plug is cool to the touch, then slowly loosen it to release the internal pressure. Then remove the oil cap or plug.

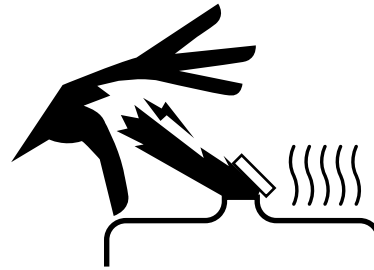

#### HIGH PRESSURE OIL

Do not attempt to repair or tighten hydraulic hoses or fittings when the engine is running or when the hydraulic circuit is pressurized.

Pressure can be maintained in the hydraulic circuit long after the engine has been shut down.

- Even though the hydraulic circuit has been left for a long time after engine stop, sometimes the pressure still remains inside the hydraulic circuit. Before refilling or draining the hydraulic oil, or inspecting or maintaining the machine, always release the pressure in the hydraulic lines by pressing the air breather of the hydraulic oil tank and loosening the connecting parts of the related hoses and connectors.

High pressure oil can penetrate the skin or eyes and cause injury, blindness or death. Fluid escaping from a small hole can be almost invisible.

- Always wear a face shield, protective glasses and gloves when inspecting for leaks.
- Always use a piece of cardboard or wood to inspect for suspected leaks.

If oil is injected into the skin, it must be removed within a few hours by a doctor familiar with this type of injury.

High pressure oil from even a pin hole leak can penetrate the skin or eyes and cause severe injury or blindness.

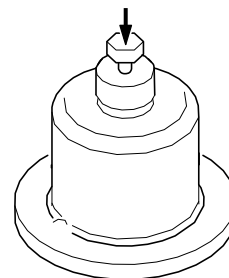

## HIGH PRESSURE FUEL IN THE FUEL LINES

During engine running, high pressure is generated inside the fuel lines of the engine.  
After engine stop, wait 1 minute before starting inspection and maintenance.

## HIGH PRESSURE OIL HOSE/PIPING

Leakage of oil or fuel from the hose or piping may cause a fire or malfunction of the machine. Stop working immediately whenever looseness of or leakage from the installation parts of the hoses or piping are found and tighten or repair them using proper repair procedures and tightening torque.  
Consult with your KOBELCO authorized dealer if damage or deformation of the hoses or piping is found.  
The hoses in below-mentioned conditions are required to be replaced.

- A damaged hose or hose with a deformed fitting.
- The sheathing material of the hose has scratches or cuttings, or exposes the wire reinforcement layer.
- A part of the sheathing material is swelled.
- A part of the hose shows a sign of twist or crush.

## ELECTRIC SHOCK

Work on the machine's electrical equipment may only be carried out by skilled electrical personnel or trained personnel under the supervision of an electrician in accordance with electrical regulations for the country in which this machine is to be used.

When working on energized equipment, always have another person positioned near the emergency-off or main switch and overvoltage release.

Contact your authorized KOBELCO dealer for assistance.

## ROTATING PARTS

Stay clear of all rotating and moving parts.

- Wrapping or entanglement may result in serious injury or death. Keep hands, clothing and tools away from the rotating fan and running fan belts. Never operate machine without guarding in place.
- Do not drop or insert tools and others to the fan and belt. They will be blown away or damaged, resulting in serious personal injury or death.
- Always have an operator at the controls to shut down the machine if the machine needs to be running for maintenance activity or an inspection. The operator and the maintenance personnel must have a means of communication when performing these tasks.

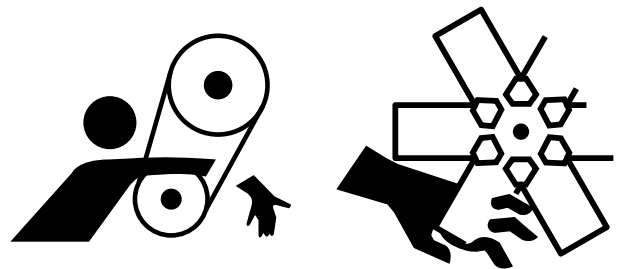

## VENTILATION PRECAUTIONS

Never operate the engine in an enclosed area without adequate ventilation. Engine exhaust contains carbon monoxide. Inspecting and maintaining the machine indoors or in a place with poor ventilation could cause serious injury or death.

Adequate ventilation is needed when inspecting, maintaining or running the machine indoors. Fully ventilate the work area, especially when handling fuel, cleaning solvent or paint.

If the natural ventilation is poor, install ventilators, fans, exhaust extension pipes or other artificial venting devices.

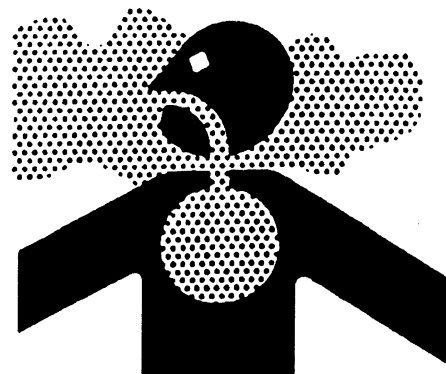

## [1. SAFETY INSTRUCTIONS]

### CONNECTING, DISCONNECTING AND STORING ATTACHMENT / EQUIPMENT

To prevent serious injury or death:

- Always follow the instructions from your supervisor and the instructions in this manual when connecting or disconnecting the attachment /equipment.
- Secure the attachment /equipment to prevent them from falling over when stored.



### SECURELY BLOCK THE MACHINE OR ANY COMPONENT THAT MAY FALL

To prevent serious injury or death, always support all the attachment /equipment when performing maintenance or inspecting underneath the machine or any raised attachment /equipment.

- Before performing maintenance or repairs under the machine, park the machine on firm level ground, lower the attachment to the ground, pull the control lock lever to the locked(up) position, stop engine, and remove the key.
- Securely block the tracks.
- If you must work beneath the raised machine or equipment, always use wood blocks, jack-stands or other rigid and stable supports to support them. Never get under the machine, the attachment /equipment, if they are not sufficiently supported.

This procedure is especially important when working on hydraulic cylinders.



### LOCK THE ACCESS PANEL

To prevent serious injury, always secure the opened door panel with the stay(1) when maintaining the machine. If the door panel is not secure, it could move and you may be injured.

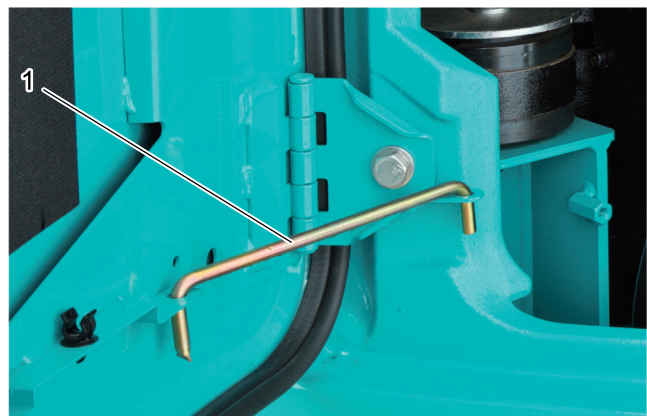

### DO NOT DROP TOOLS OR PARTS

Falling tools or parts may cause damage to the machine or cause unintended movement of the machine and result in serious injury or death.

- Retrieve any tools that fall immediately.
- Always secure tools or parts that are near the machine and store tools properly after maintenance is complete.

## USE CAUTION WHEN ADJUSTING THE CRAWLER TENSION

The crawler adjuster contains high pressure grease. If the tension is adjusted without following the prescribed procedure below, the grease fitting may fly off and discharge grease, resulting in serious injury. Always wear suitable protective gears.

- Always wear suitable protective gears.
- Do not put your face, arms, legs or body in front of the grease fitting. If grease contacts your skin, wash completely with soap and water to avoid skin inflammation.
- Loosen the grease fitting one turn to gradually relieve pressure. If grease does not come out after one turn of the grease fitting, there is a problem. Call your KOBELCO authorized dealer for assistance.
- Loosen the grease fitting slowly.  
After relieving the grease pressure, see "ADJUSTING CRAWLER TENSION" in Chapter 4 for additional information about how to adjust the crawler tension.



## DO NOT DISASSEMBLE THE RECOIL SPRING

Never attempt to disassemble the recoil spring. The recoil spring assembly acts as a shock absorber for the front idler and contains a powerful spring under tension. If it is disassembled, the spring will eject from the assembly and result in severe personal injury or death.

If there is an issue with the recoil spring assembly, contact your KOBELCO authorized dealer for repair.

## BEFORE HAMMERING METAL PINS, TEETH OR BEARINGS

Always wear required personal protective equipment such as safety glasses when using hammers, as metal fragments or other objects can fly and cause serious personal injury.

Broken metal pieces may cause severe personal injury when hammering metal pins, teeth or bearings.

To avoid injury:

- Wear protective gears such as safety glasses, gloves, hardhat, protective shoes, etc.
- Confirm the work area is clear of personnel before using hammer.
- Use a piece of wood or similar material to absorb the direct impact of the hammer when removing metal pins, teeth or bearings.

## BEFORE HAMMERING METAL PINS, TEETH OR BEARINGS

Always wear required personal protective equipment such as safety glasses when using hammers, as metal fragments or other objects can fly and cause serious personal injury.

Broken metal pieces may cause severe personal injury when hammering metal pins, teeth or bearings.

To avoid injury:

- Wear protective gears such as safety glasses, gloves, hardhat, protective shoes, etc.
- Confirm the work area is clear of personnel before using hammer.
- Use a piece of wood or similar material to absorb the direct impact of the hammer when removing metal pins, teeth or bearings.

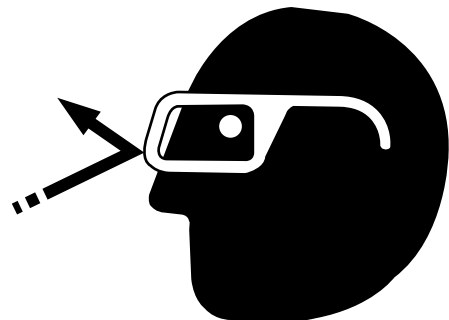

## [1. SAFETY INSTRUCTIONS]

---

### BE AWARE OF THE HAZARDS WITH THE REFRIGERANT AND THE AIR CONDITIONING SYSTEM

- Do not loosen the refrigerant circuit parts. If refrigerant gets in your eyes, it may cause loss of sight including potential blindness. Do not touch the refrigerant circuit parts. If refrigerant gets on your skin, it may cause frostbite.
- Do not inhale refrigerant gas; and
- Keep refrigerant gas away from heat sources.

Dispose of refrigerant according to local codes and regulations of each country.

If you need additional assistance, contact your KOBELCO authorized dealer about proper disposal of refrigerant. The temperature of the refrigerant gas compressed by the compressor becomes a high temperature. Until the temperature of the refrigerant gas goes down, do not touch the compressor, the hose, and the condenser by bare hand.

## 1.6.4 CAUTION IN HANDLING OF WELDING

### NEVER USE HEAT NEAR HYDRAULIC EQUIPMENT, PIPING OR HOSES

When welding, soldering or using a torch, do not expose piping and hoses containing pressurized oil to heat. Heat may create the potential for exposure to flammable gas and result in a fire.

Always cover hydraulic equipment, piping, hoses and other flammable items with fire-proof blankets. Keep a suitable fire extinguisher readily available.



### DO NOT HEAT PIPING WITH FLAMMABLE OIL

- Do not weld or perform gas cutting on pipes and tubes filled with flammable oil.
- Remove flammable oil from pipes and tubes using nonflammable solvent before welding and gas cutting.

### DO NOT MODIFY MACHINE WITHOUT APPROVAL FROM KOBELCO

- Any and all modifications to this machine must be approved by KOBELCO.
- Unauthorized modification of the machine is not covered by the warranty provided with this machine.

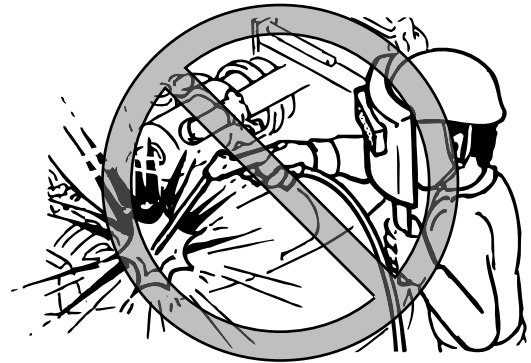

### GENERAL GUIDELINES FOR WELDING

Contact manufacturer, or authorized KOBELCO dealer before welding on machine. Welding could damage wires, electronic processors, hoses, and tubes. Any welding on structural parts (as undercarriage, upper frame, equipment parts,...) should only be done by the manufacturer, or authorized KOBELCO dealer. Welding performed by others will void the warranty for your machine.

Do not weld tanks or lines that contain flammable fluids or flammable material. Empty and purge the lines and tanks. Then clean the lines and tanks with a nonflammable solvent prior to welding or flame cutting.

To prevent serious injury or possible fire, welding work must be performed by a certified welder at a facility with welding devices suitable for the task.

## [1. SAFETY INSTRUCTIONS]

---

### BASIC PRECAUTIONS FOR WELDING AND GRINDING

- Always wear protective gears appropriate for welding.
- Perform work in a well-ventilated area.
- Keep a suitable fire extinguisher readily available.
- Before welding, select a location away from flammable items and have a fire extinguisher nearby. Ensure adequate ventilation.
- Turn the engine off and remove the key.
- Disconnect the negative (-) cable from its battery terminal. When the battery power-off switch is provided, set it to "OFF".
- Remove or adequately shield all components, hoses, tubes, and wires in the area.
- Ensure that the components are properly grounded in order to avoid unwanted arcs. Attach the welder ground cable directly to the area within 1 m (3 ft.) from the part to be welded and on the same parent material. If the welder ground cable is attached to the area near electric parts/connectors, these electric parts/connectors may be damaged.
- Make sure neither the bearing nor the bearing seal is between the welder ground cable and the part to be welded.
- Do not attach the welder ground cable near the pin or cylinder. It will damage the plating on the pin or cylinder.
- Remove paint from any surface to be welded to avoid generating poisonous gas.
- After grinding or welding, confirm there is no smoke or fire near the work area.

### 1.6.5 AFTER COMPLETION OF MAINTENANCE

#### AFTER MAINTENANCE

Before returning machine to service, always confirm there are no leaks and the controls are functioning properly.

- Run the engine at low idle speed and check for oil or water leaks.
- Slowly operate each control lever and check that it is functioning properly.
- Then gradually increase the engine speed and check for oil or water leaks again.
- Manipulate each control lever again and check that it is functioning properly.
- Close the doors, guards, engine hood, etc.

#### PROPER WASTE DISPOSAL

- Drain used fluids from the machine into leak proof containers. Clearly mark the type of fluid on the containers.
- Never pour used oil or other fluids onto the ground, down a drain or into any body of water. Improper disposal can harm the environment. Contact your local government or public service company to ask about proper disposal methods.
- Properly dispose of oil, fuel, engine coolant, urea water, refrigerant, solvents, filters, batteries and other harmful substances according to local, state and federal environmental regulations for the country in which the machine is located.

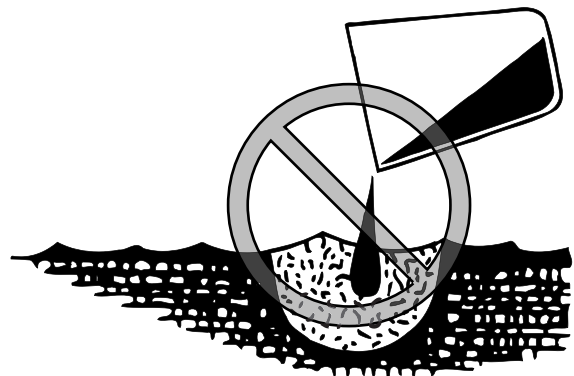



## 1.7 PRECAUTIONS FOR BATTERY



### READ THE OPERATOR'S MANUAL

Read, understand and follow the safety messages and instructions in this manual. If these safety messages are not followed, serious injury or death could occur.

### 1.7.1 HANDLING THE BATTERY

#### PREVENTION OF ELECTROLYTE BURNS

Wear safety glasses or face shield, and chemical resistant gloves and clothing when handling or servicing batteries.

Battery electrolyte contains dilute sulfuric acid.

Electrolyte will damage eyes or skin on contact. If battery electrolyte contacts skin or eyes, flush affected areas immediately with a large amount of fresh water, then seek medical attention.

Wash hands after touching batteries and connectors.



#### BATTERY EXPLOSION PREVENTION

- Always keep cigarettes, flames and other ignition sources away from batteries.  
Batteries give off hydrogen gases that can explode and cause serious injury or death.
- Always keep all battery caps tightly secured.



#### CHARGING THE BATTERY

See "USING JUMPER CABLES" in Chapter 3.

#### REPLACING THE BATTERY

See "CHECKING BATTERY VOLTAGE" in Chapter 4.

#### BATTERY DISPOSAL

Dispose of batteries according to local codes and regulations of each country.

If you need additional assistance, contact your KOBELCO authorized dealer about proper disposal of used batteries.

## 1.8 HANDLING OF THE ACCUMULATOR OR GAS SPRING

---



### WARNING READ THE OPERATOR'S MANUAL

Read, understand and follow the safety messages and instructions in this manual. If these safety messages are not followed, serious injury or death could occur.

---

High pressured nitrogen gas is sealed inside the accumulator or gas spring.

To prevent serious injury or death:

- Never attempt to disassemble accumulator or gas spring.
- Never drill or weld, or perform gas cutting on accumulator or gas spring.
- Keep fire and other ignition sources away from the accumulator or gas spring.
- Never throw accumulator or gas spring into fire.
- Ask your KOBELCO authorized dealer to vent the gas from the accumulator or to remove the gas spring before disposal.



## 2. MACHINE FAMILIARIZATION



## 2.1 BASIC COMPONENTS OF THE MACHINE

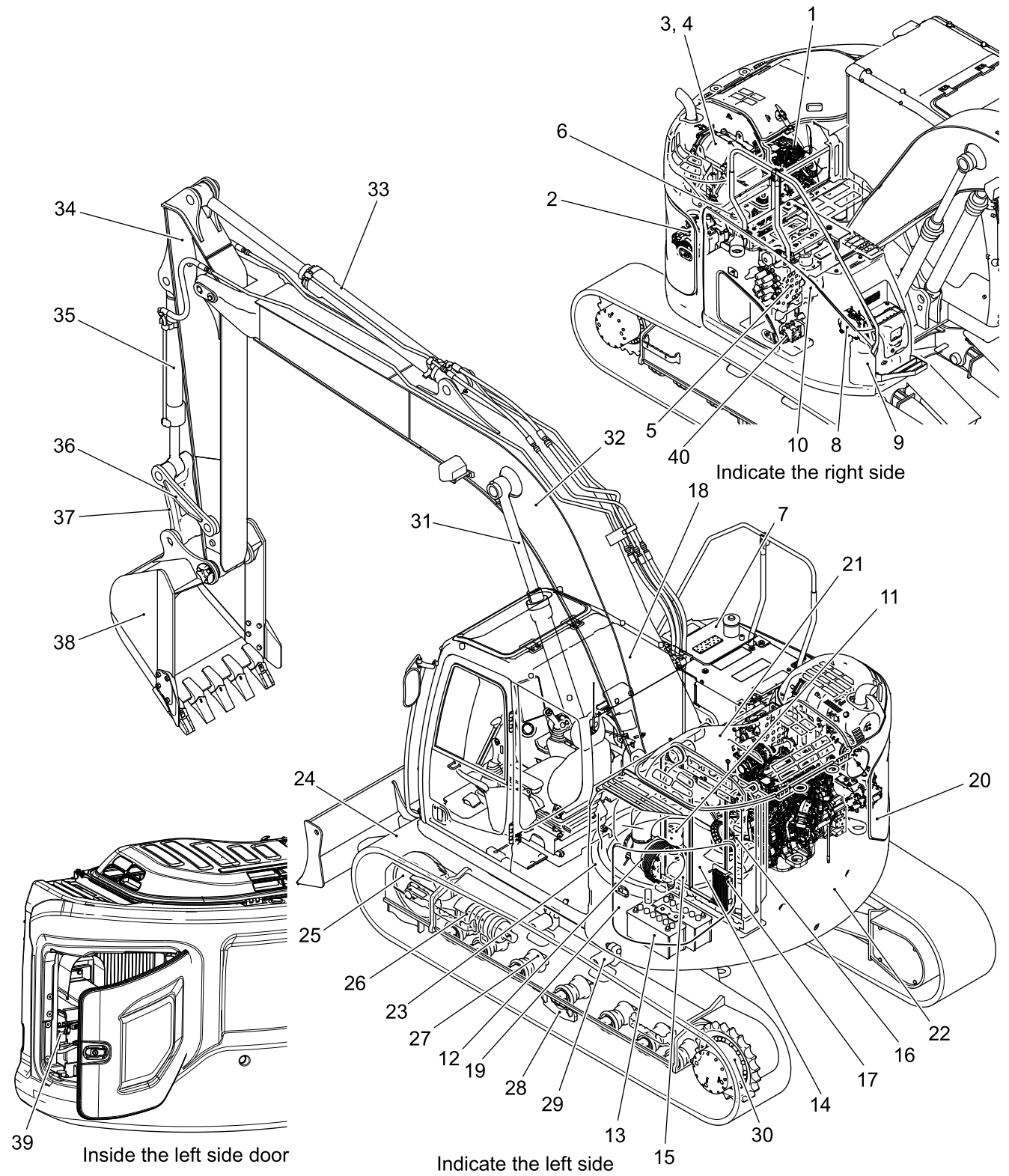

## [2. MACHINE FAMILIARIZATION]

Item	Name	Item	Name	Item	Name
1	Engine	15	Radiator	29	Upper roller
2	Hydraulic pump	16	Intercooler	30	Travel motor
3	Exhaust gas cleaning device	17	Fuel cooler	31	Boom cylinder
4	SCR	18	Cab	32	Boom
5	Control valve	19	Left side door	33	Arm cylinder
6	Hydraulic oil tank	20	Right side door	34	Arm
7	Fuel tank	21	Engine hood	35	Bucket cylinder
8	DEF/AdBlue pump	22	Counterweight	36	Idler link
9	DEF/AdBlue tank	23	Swing bearing	37	Bucket link
10	Swing motor	24	Crawler	38	Bucket
11	Swivel joint	25	Front idler	39	Battery power-off switch
12	Air cleaner	26	Crawler adjuster	40	Multi control valve
13	Battery	27	Lower Roller		
14	Oil cooler	28	Track guide		

## 2.2 OPERATOR'S STATION NOMENCLATURE

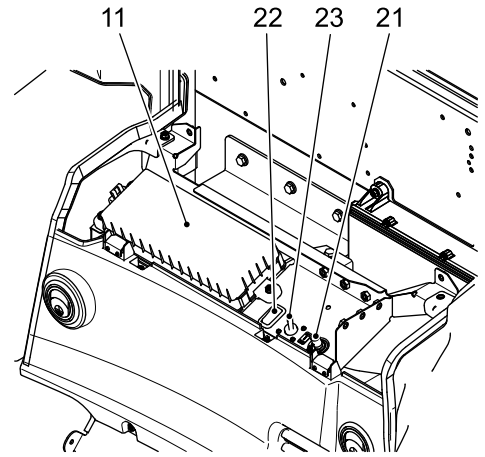
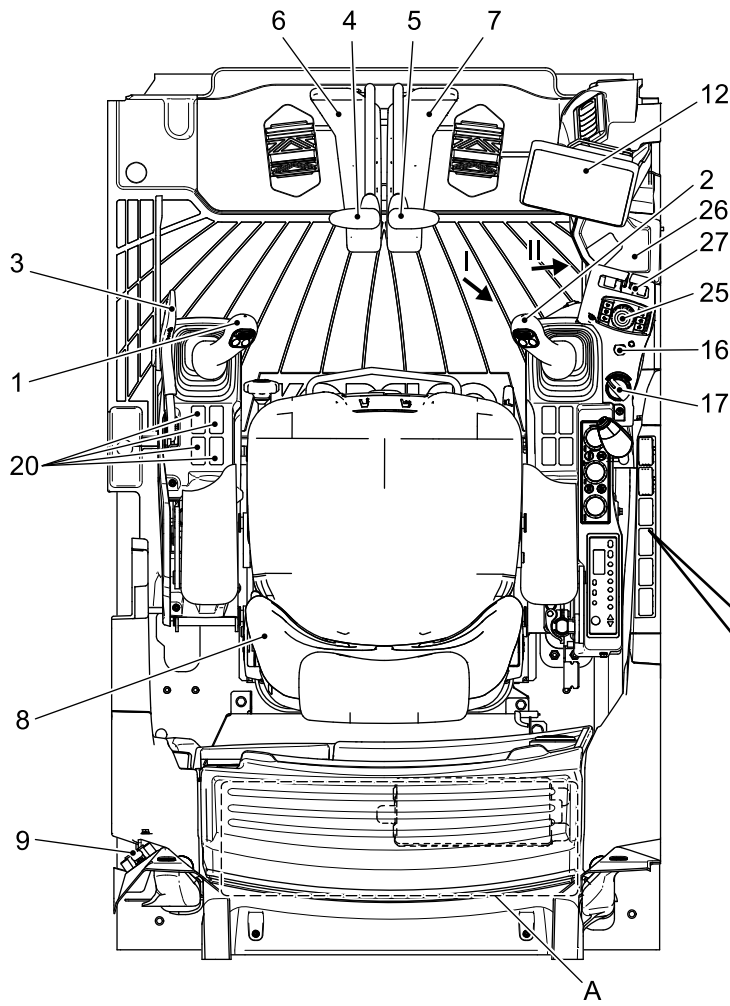

DETAIL A

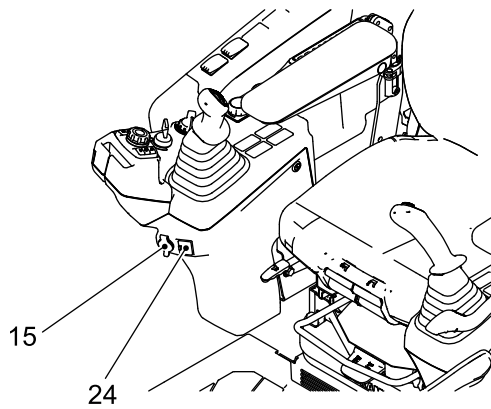
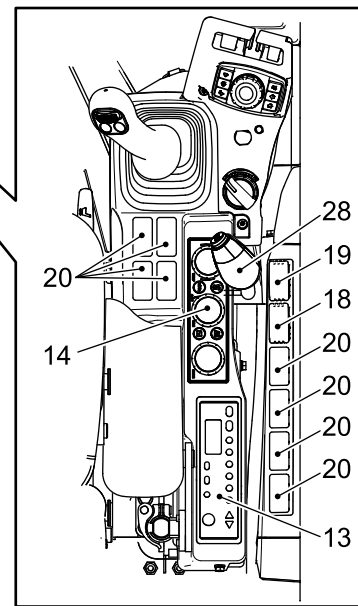

VIEW I

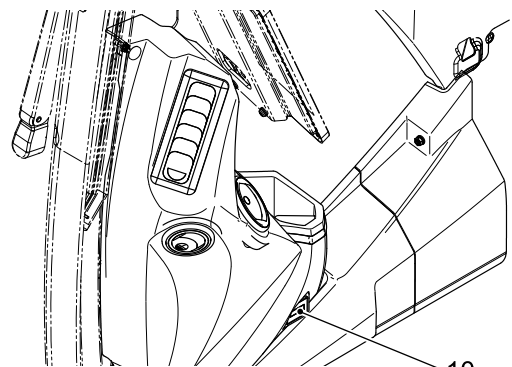

VIEW II

2

## [2. MACHINE FAMILIARIZATION]

Item	Name	Item	Name
1	Left control lever (with horn switch)	15	12V power supply
2	Right control lever	16	Starter switch
3	Control lock lever	17	Engine throttle
4	Left travel lever	18	Working light (boom and deck)
5	Right travel lever	19	Manual regeneration switch
6	Left travel pedal	20	Cap (Optionally installed switch)
7	Right travel pedal	21	Emergency accel
8	Operator's seat	22	Swing parking brake release switch
9	Life hammer	23	KPSS release switch
10	Hour meter	24	USB port/external input terminal (AUX)
11	Fuse and relay box	25	Switch box
12	Monitor	26	Cup holder
13	Radio	27	Holder for Smart phone
14	Air conditioner operation panel	28	Dozer operation lever (with travel speed select switch)



## 2.3 MONITOR

### 2.3.1 NORMAL SCREEN

According to the types of the exhaust gas cleaning devices, the display of portion C is changed. This manual explains operations based on the screens of the DPF and the SCR.

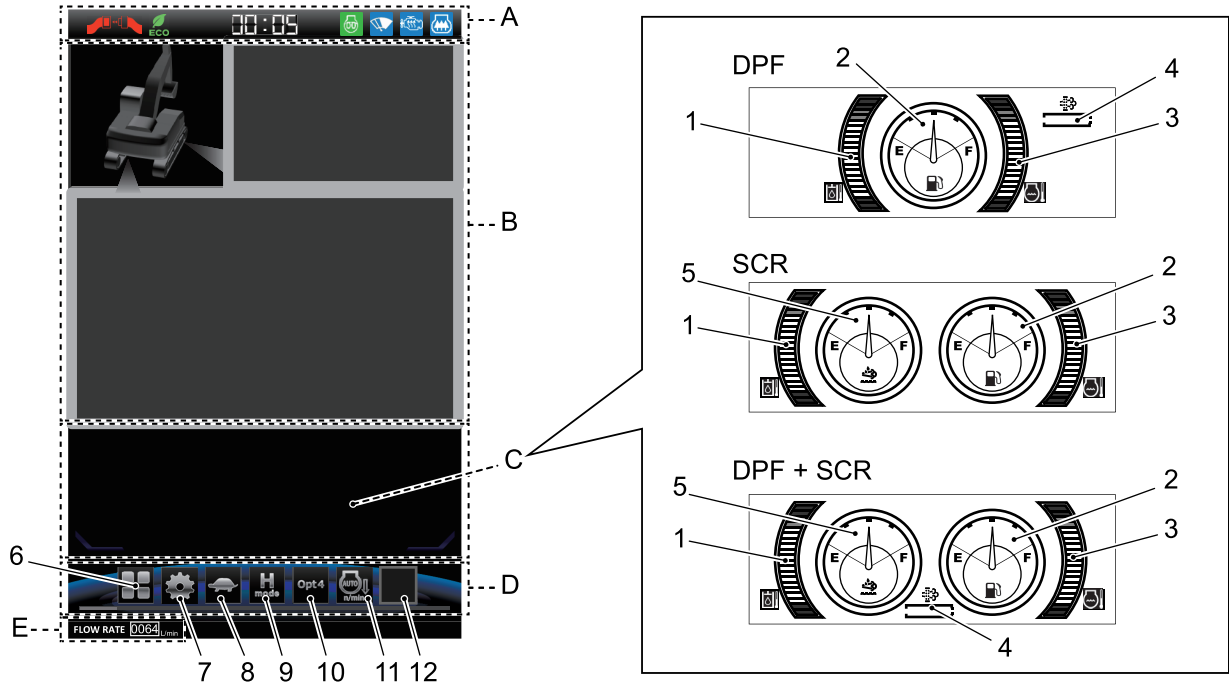

Symbol	Display	
A	Notification icons/clock	
B	The images captured by the rearview camera and the side cameras are displayed.	
C	Meter	1 Hydraulic oil temperature meter
		2 Fuel level meter
		3 Engine coolant temperature meter
		4 Soot deposition meter
		5 DEF/AdBlue level gauge
D	Switch	6 Setting menu
		7 Switch setting
		8 Travel speed selection
		9 Work mode selection
		10 Attachment mode selection
		11 Auto acceleration ON/OFF selection
		12 Range of option display
E	Set flow rate of front attachment The flow rate at a light load work becomes a set value and is displayed.	

2

## [2. MACHINE FAMILIARIZATION]

### 2.3.2 SWITCH DISPLAY

The number of switch indications changes according to the position of the control lock lever.

#### Notice

When the control lock lever is raised upward to the locked(up) position, setting for changing the screen becomes possible.

**When the lever is raised upward to the locked(up) position**

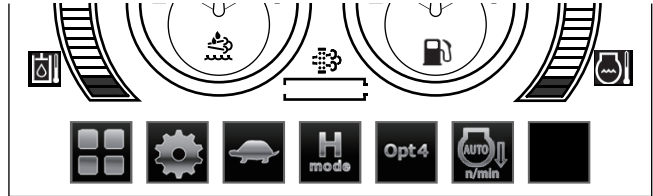

**When the lever is push down to the "UNLOCKED" position**

The switches for setting of changing the screen become invisible.

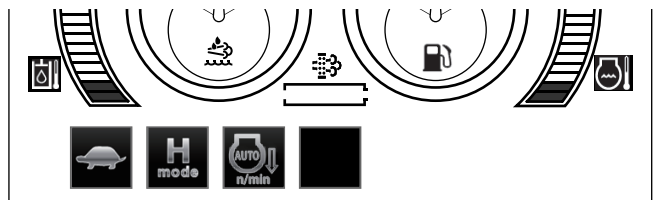

### 2.3.3 NOTIFICATION ICON

Display	Summary
	Seat belt display Displayed 30 seconds after the starter switch is turned "ON".
	Displayed at the operation of low fuel consumption.
	Displayed when the auto idle stop function is being actuated.
	Displayed when the glow plug is being actuated.
	Displayed at the auto warming-up.
	Displayed when the wiper is being actuated.

### 2.3.4 HYDRAULIC OIL TEMPERATURE METER

The meter shows the hydraulic oil temperature. After the starter switch is turned to the "ON" position, bars are displayed on the monitor.

As the hydraulic oil temperature rises, the bars increase. If the bars indicating a high temperature appear during operation, set the engine throttle to the low idle position, pull up the control lock lever to the locked(up) position, and do not perform any lever operations until the bars indicating a high temperature disappear and the bars are decreased to the normal temperature range(c).

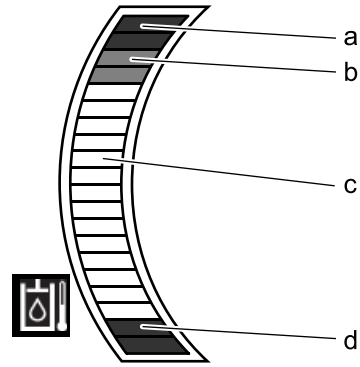

Symbol	Color of bars	Temperature
a	Red	High temperature Warning sounds.
b	Orange	High temperature
c	White	Normal
d	Blue	Low temperature

### 2.3.5 FUEL LEVEL METER

The meter shows the amount of fuel in the fuel tank. After the starter switch is turned to the "ON" position, the fuel level meter is displayed on the monitor. The remaining amount of fuel is indicated with the pointer, and when the fuel level is low, the pointer indicates point E. When the fuel level is low, see "CHECKING FUEL LEVEL AND REFUELING" in Chapter 3 in the operation manual, and supply fuel.

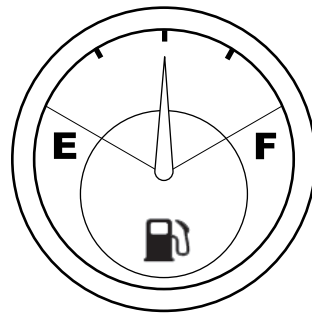

### 2.3.6 ENGINE COOLANT TEMPERATURE METER

The meter indicates the temperature of the engine coolant. After the starter switch is turned to the "ON" position, bars are displayed on the monitor. As the engine coolant temperature rises, the bars increase.

If the bars indicating a high temperature appear during operation, set the engine throttle to the low idle position, pull up the control lock lever to the locked(up) position, and do not perform any lever operations until the bars indicating a high temperature disappear and the bars are decreased to the normal temperature range(c).

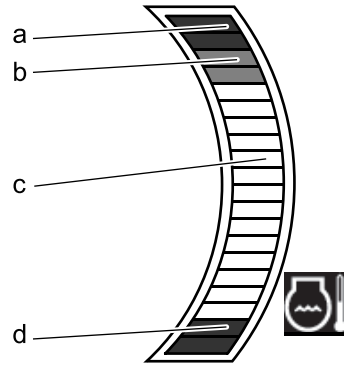

Symbol	Color of bars	Temperature
a	Red	Overheat Warning sounds. The engine speed becomes limited.
b	Orange	High temperature
c	White	Normal
d	Blue	Low temperature

### 2.3.7 DEF/ADBLUE LEVEL GAUGE

The level gauge indicates the DEF/AdBlue level in the DEF/AdBlue tank. After turning the starter switch "ON", the level gauge of DEF/AdBlue is displayed on the monitor.

The amount of DEF/AdBlue is indicated with a pointer, and when the DEF/AdBlue level is low, the pointer points E. The amount of DEF/AdBlue is proper if the pointer points the place higher than yellow (a). When the pointer points the range of yellow (a) or red (b), the warning is displayed on the monitor and the warning sounds. At that time, see "CHECKING DEF/ADBLUE LEVEL AND REFILLING" in Chapter 3 of the operation & maintenance manual and refill DEF/AdBlue.

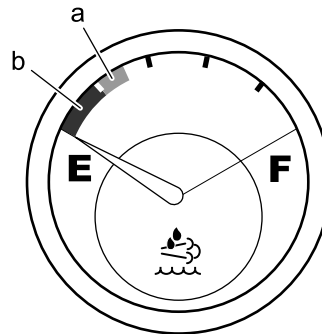

## 2.3.8 SWITCH BOX

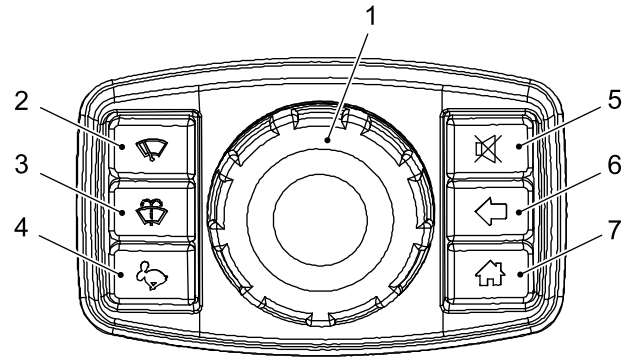

Item	Name	Function
1	Jog dial	Controls the cursor on the monitor and switches the screen.
2	Wiper switch	Activates the wiper.
3	Washer switch	Sprays the washer fluid to the front window.
4	Travel speed select switch	Switches the travel speed.
5	Buzzer stop switch	Stops buzzer sounding.
6	Return switch	Returns the monitor screen to the previous screen.
7	Home switch	Returns the monitor screen to the normal screen.

## [2. MACHINE FAMILIARIZATION]

Example of operating monitor

### Jog dial operation

#### Tilting (a,b,c,d) and rotating (e,f) the jog dial

To move the cursor on the monitor and adjust the values and others.

#### Pushing down (g) the jog dial

- To switch the screen to the selected setting screen.
- To determine the adjusted value and others.

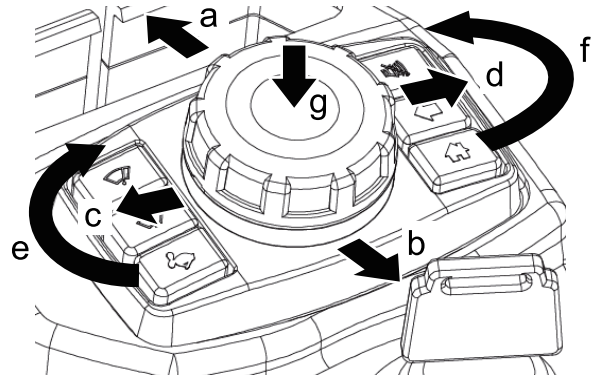

### How to move the cursor

- (c) Tilt the jog dial left
- (d) Tilt the jog dial right
- (e) Turn the jog dial clockwise
- (f) Turn the jog dial counterclockwise

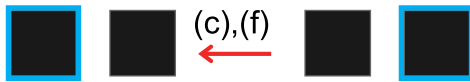

- (a) Tilt the jog dial forward
- (b) Tilt the jog dial rearward

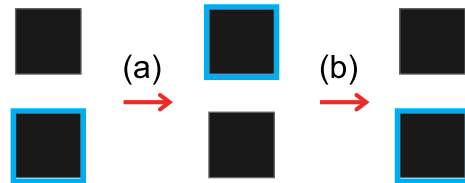

- (e) Turn the jog dial clockwise
- (f) Turn the jog dial counterclockwise

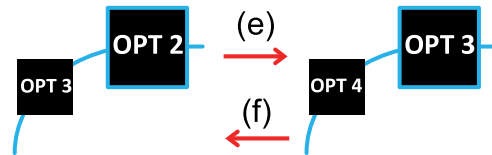

### How to set the adjustable value in each item

#### Increasing the value

- (a) Tilt the jog dial forward
- (e) Turn the jog dial clockwise

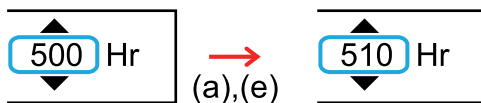

#### Decreasing the value

- (b) Tilt the jog dial rearward
- (f) Turn the jog dial counterclockwise

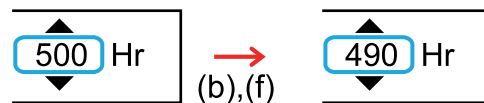

## 2.3.9 SETTING MENU SCREEN

**Notice**

When the control lock lever is raised upward to the "LOCKED" position, setting for changing the screen becomes possible.

### Jog dial operation

#### Tilting (a,b,c,d) and rotating (e,f) the jog dial

To move the cursor on the monitor and adjust the values and others.

#### Pushing down (g) the jog dial

- To switch the screen to the selected setting screen.
- To determine the adjusted value and others.

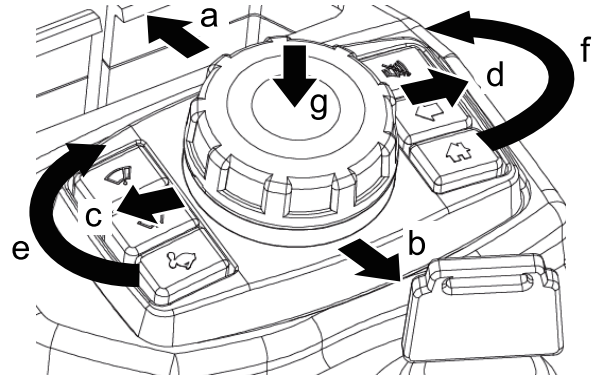

1. Tilt and turn the jog dial to move the cursor to setting menu (5) on the monitor.
2. Push down (g) the jog dial to switch the monitor to the [SETTING MENU] screen

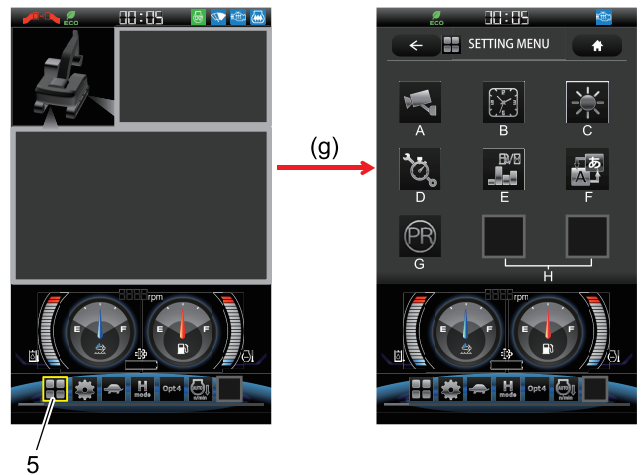

A	B	C
PICTURE OF CAMERA	CLOCK SETTING	SCREEN BRIGHTNESS
D	E	F
MAINTENANCE	CONSUMPTION	LANGUAGE SELECTION
G	H	
	An icon for option will be located.	
PRESSURE RELEASE		



## [2. MACHINE FAMILIARIZATION]

### PICTURE OF CAMERA

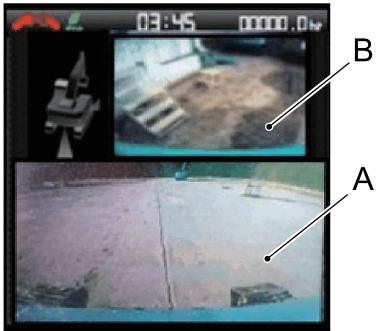
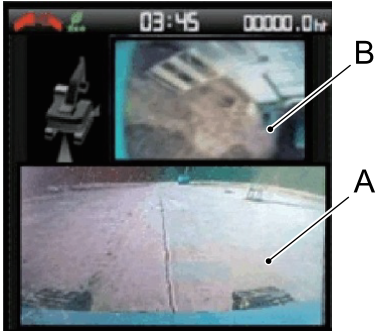

This menu allows you to select the picture layout of the camera displayed on the normal screen.

### Layout of camera images

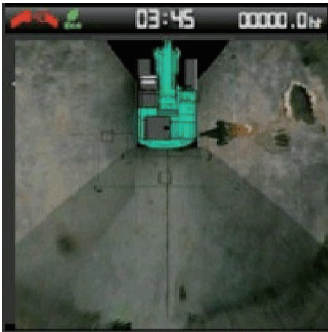
Layout 1	Layout 2	Layout 3
		
<p>(A) Image captured by rearview camera (B) Image captured by right side camera</p>	<p>(A) Image captured by rearview camera (B) Image captured by right side camera</p>	<p>Synthetic image made from images captured by right side camera and rearview camera</p>
Layout 4		
		
<p>Synthetic image made from images captured by left and right side cameras and rearview camera</p>		



**Jog dial operation**

**Tilting (a,b,c,d) and rotating (e,f) the jog dial**

To move the cursor on the monitor and adjust the values and others.

**Pushing down (g) the jog dial**

- To switch the screen to the selected setting screen.
- To determine the adjusted value and others.

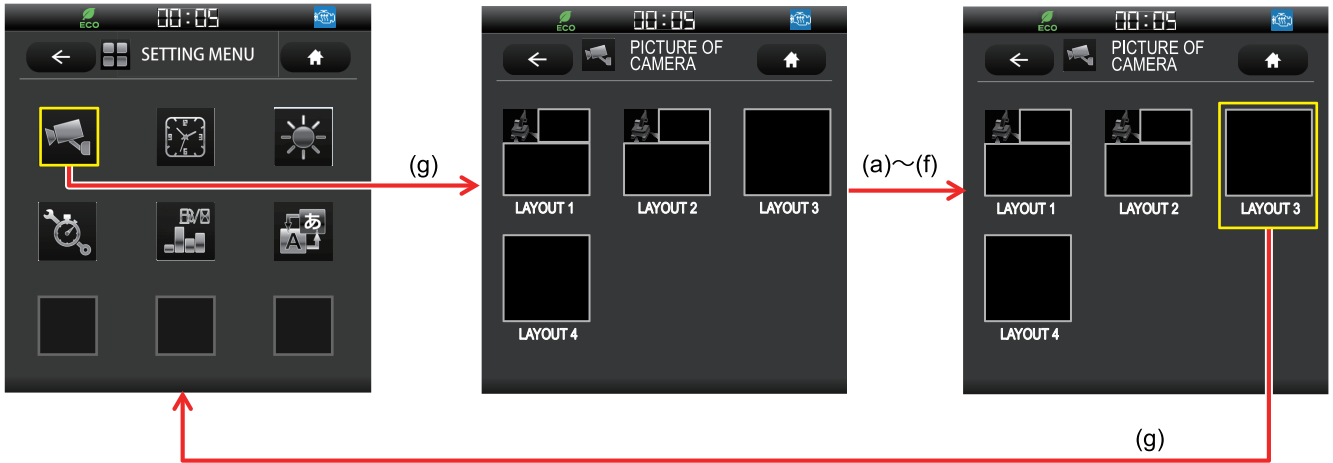
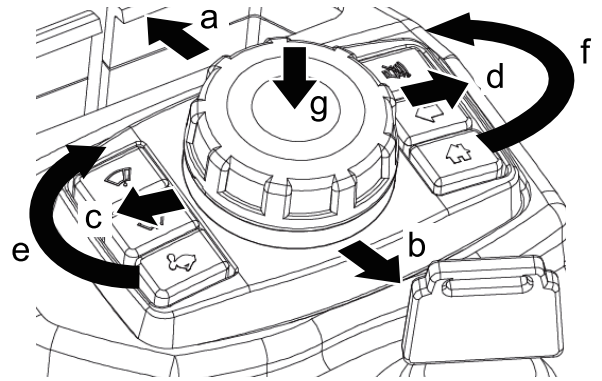

2

1. Switch the monitor to the [SETTING MENU] screen.
2. Tilt and turn the jog dial to move the cursor to [PICTURE OF CAMERA] on the [SETTING MENU] screen.
3. Push down (g) the jog dial to switch the monitor to the [PICTURE OF CAMERA] screen.
4. Tilt and turn the jog dial to move the cursor to a desired layout.
5. Push down (g) the jog dial to set the selected layout and return the monitor to the [SETTING MENU] screen.

CLOCK SETTING



This menu allows you to set the clock.

**Jog dial operation**

**Tilting (a,b,c,d) and rotating (e,f) the jog dial**

To move the cursor on the monitor and adjust the values and others.

**Pushing down (g) the jog dial**

- To switch the screen to the selected setting screen.
- To determine the adjusted value and others.

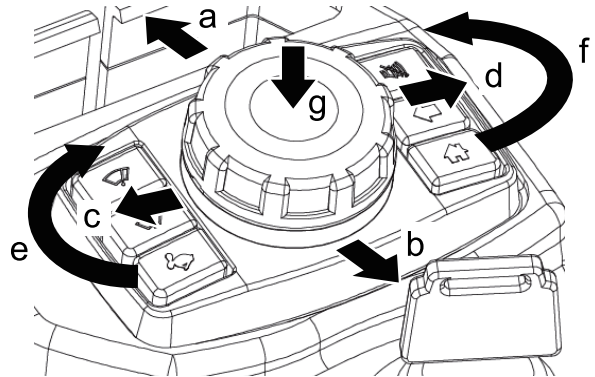

1. Switch the monitor to the [SETTING MENU] screen.
2. Tilt and turn the jog dial to move the cursor to [CLOCK SETTING] on the [SETTING MENU] screen.
3. Push down (g) the jog dial to switch the monitor to the [CLOCK SETTING] screen.
4. Tilt and turn the jog dial to move the cursor to a desired item to set.
5. Push down (g) the jog dial to enable the selected item to be adjustable.
6. Tilt and turn the jog dial to a desired value.
7. Push down (g) the jog dial to set the desired value.
8. Tilt and turn the jog dial to move the cursor to [OK].
9. Push down (g) the jog dial to return the monitor to the [SETTING MENU] screen.

SCREEN BRIGHTNESS



This menu allows you to adjust the screen brightness.

**Setting of day brightness**

Adjust the screen brightness when the working light is "OFF".

**Setting of night brightness**

Adjust the screen brightness when the working light is "ON".

**Jog dial operation**

**Tilting (a,b,c,d) and rotating (e,f) the jog dial**

To move the cursor on the monitor and adjust the values and others.

**Pushing down (g) the jog dial**

- To switch the screen to the selected setting screen.
- To determine the adjusted value and others.

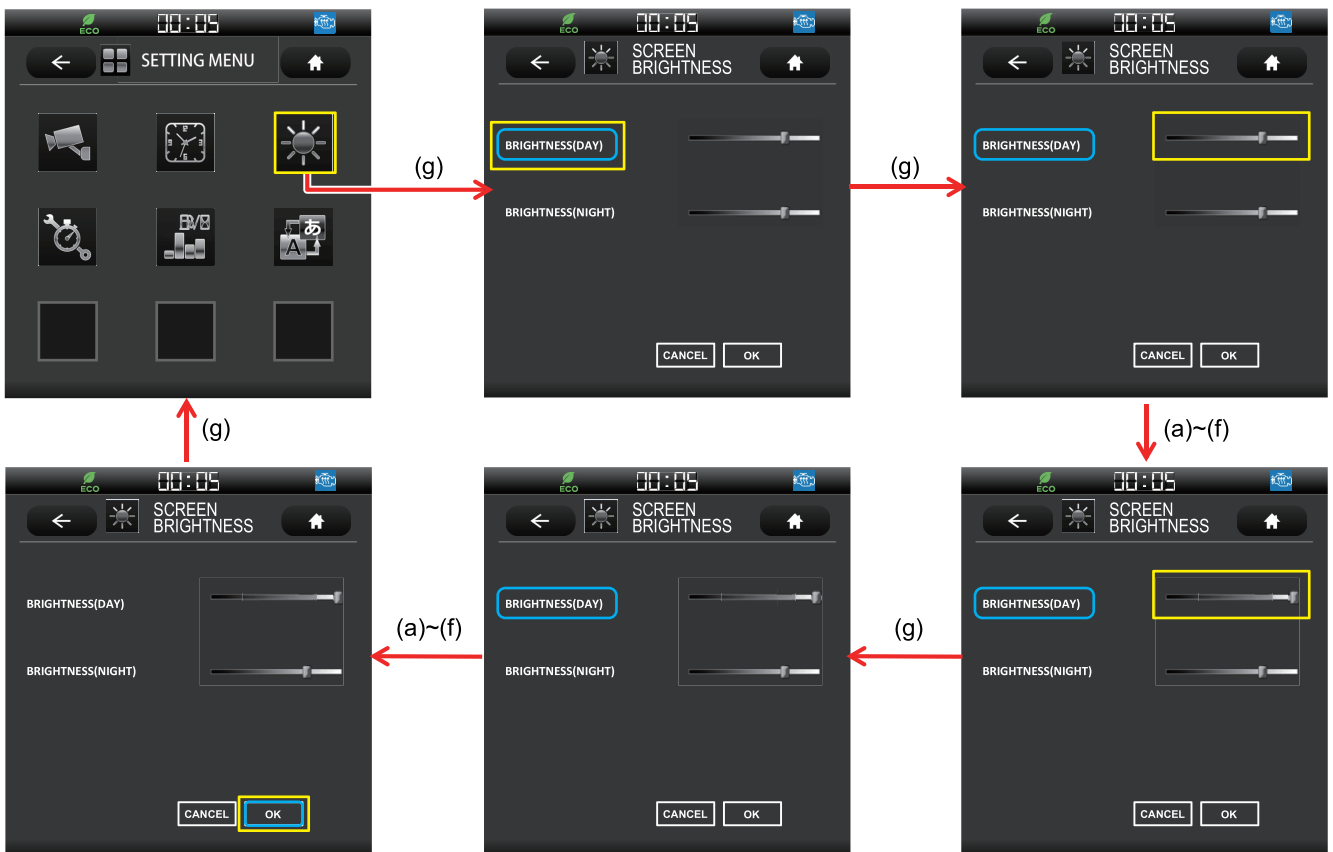
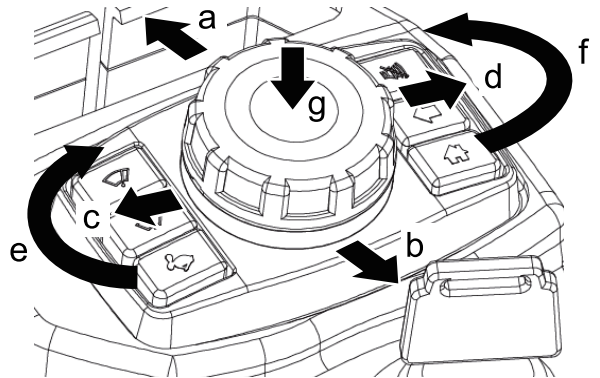

1. Switch the monitor to the [SETTING MENU] screen.
2. Tilt and turn the jog dial to move the cursor to [SCREEN BRIGHTNESS] on the [SETTING MENU] screen.
3. Push down (g) the jog dial to switch the monitor to the [SCREEN BRIGHTNESS] screen.
4. Tilt and turn the jog dial and move the cursor to a desired item to set.

## [2. MACHINE FAMILIARIZATION]

---

5. Push down (g) the jog dial to enable the selected item to be adjustable.
6. Tilt and turn the jog dial to move the slider left or right to desired screen brightness.
7. Push down (g) the jog dial to set the desired screen brightness.
8. Tilt and turn the jog dial to move the cursor to [OK].
9. Push down (g) the jog dial to return the monitor to the [SETTING MENU] screen.

MAINTENANCE



This menu allows you to display the remaining time to the end of the set replacement interval of the filter/oil. Also, you can set the next replacement interval.

After the replacement interval is reached, inspect and maintain the part following to "INSPECTION AND MAINTENANCE" in Chapter 4 in the operation manual.

**In case of after replacement interval**

- The warning is displayed on the monitor.
- The color of the remaining time display in the [MAINTENANCE] changes to red.

**Notice**

After the replacement interval is reached, the buzzer sounds, if the machine setting has been changed. If needed, contact your KOBELCO authorized dealer.

**Jog dial operation**

**Tilting (a,b,c,d) and rotating (e,f) the jog dial**

To move the cursor on the monitor and adjust the values and others.

**Pushing down (g) the jog dial**

- To switch the screen to the selected setting screen.
- To determine the adjusted value and others.

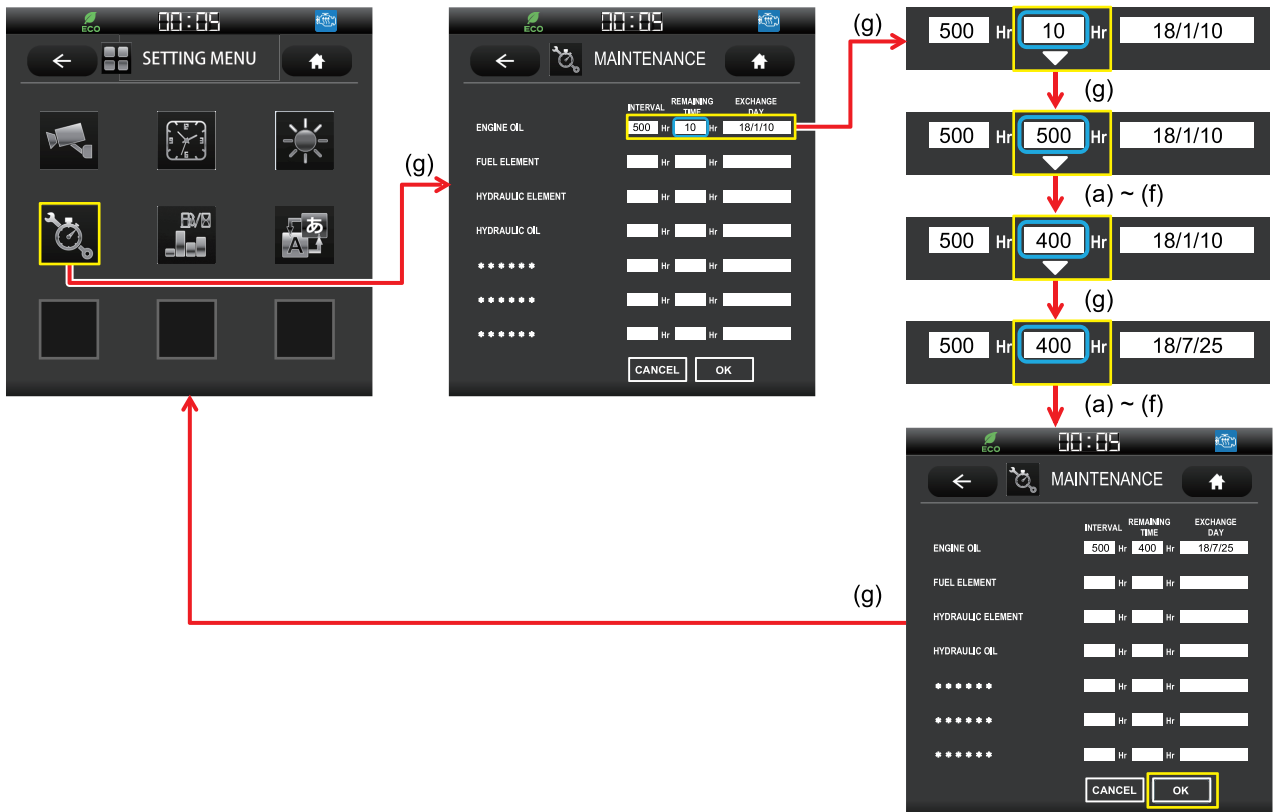
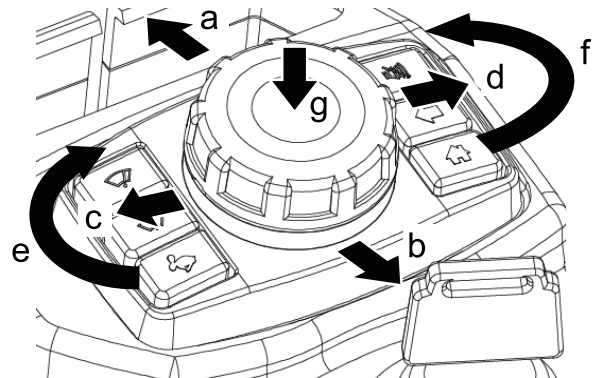

1. Switch the monitor to the [SETTING MENU] screen.

## [2. MACHINE FAMILIARIZATION]

---

2. Tilt and turn the jog dial to move the cursor to [MAINTENANCE] on the [SETTING MENU] screen.
3. Push down (g) the jog dial to switch the monitor to the [MAINTENANCE] screen.
4. Tilt and turn the jog dial to move the cursor to [REMAINING TIME] of a desired item to set.
5. Push down (g) the jog dial to reset [REMAINING TIME] to the equal value of [INTERVAL] and enable the selected item to be adjustable.
6. Tilt and turn the jog dial to a desired value.  
The value cannot exceed [INTERVAL].
7. Push down (g) the jog dial to set the desired value.  
At this time, [EXCHANGE DAY] is renewed.
8. Tilt and turn the jog dial to move the cursor to [OK].
9. Push down (g) the jog dial to return the monitor to the [SETTING MENU] screen.

CONSUMPTION



The monitor display of the fuel efficiency can be set.

**Jog dial operation**

**Tilting (a,b,c,d) and rotating (e,f) the jog dial**

To move the cursor on the monitor and adjust the values and others.

**Pushing down (g) the jog dial**

- To switch the screen to the selected setting screen.
- To determine the adjusted value and others.

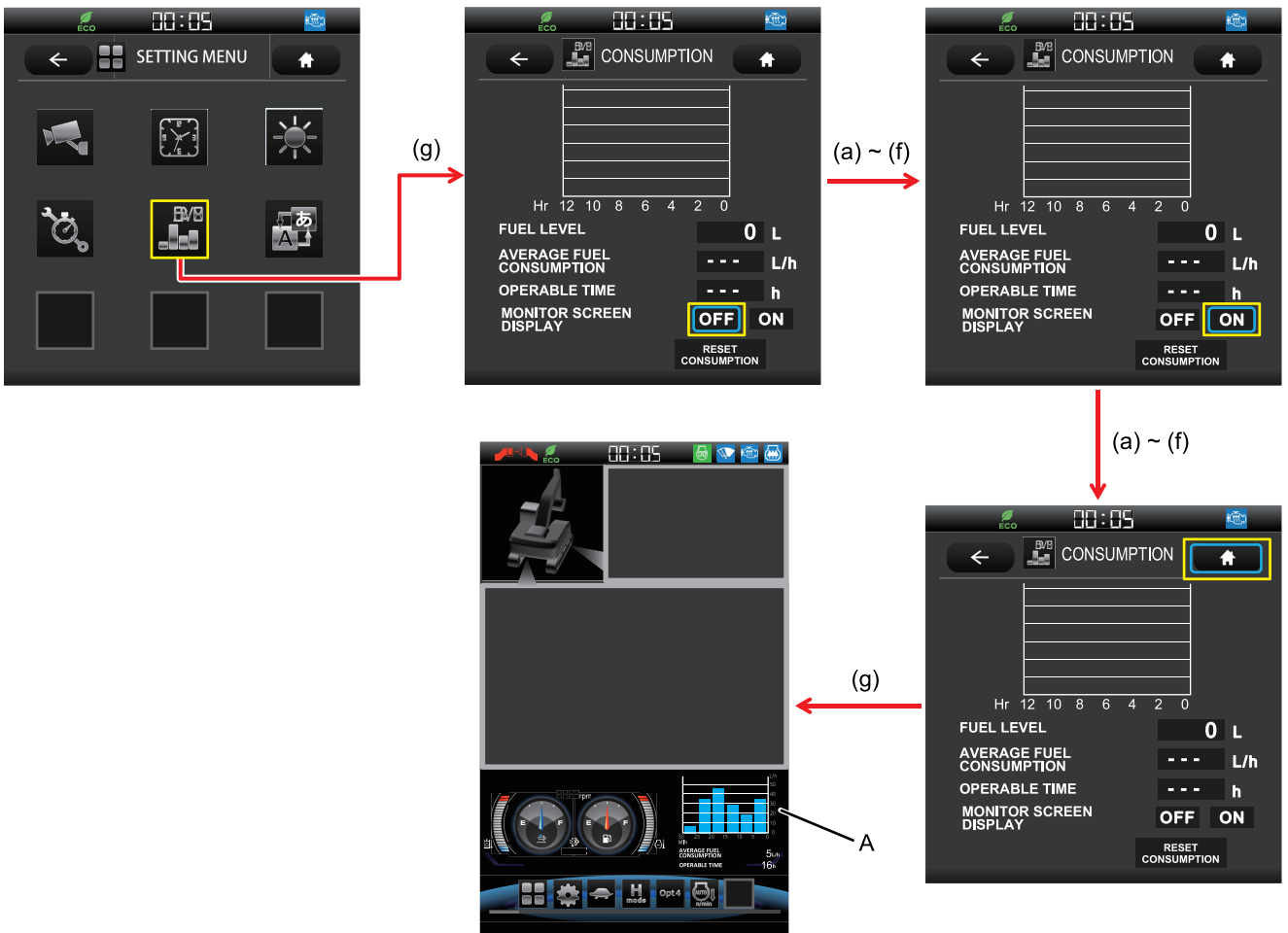
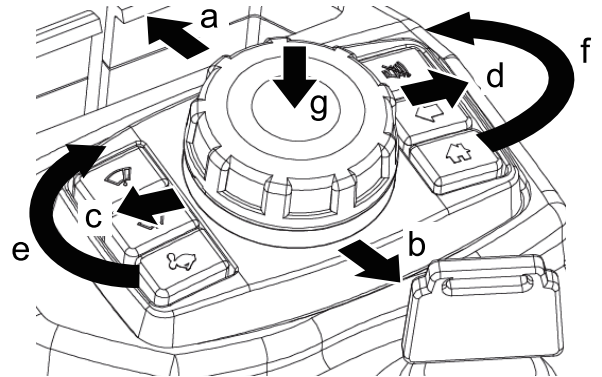

1. Switch the monitor to the [SETTING MENU] screen.
2. Tilt and turn the jog dial to move the cursor to [CONSUMPTION] on the [SETTING MENU] screen.
3. Push down (g) the jog dial to switch the monitor to the [CONSUMPTION] screen.
4. Tilt and turn the jog dial to move the cursor to [ON] of [MONITOR SCREEN DISPLAY]
5. Push down (g) the jog dial to switch the setting to [ON].
6. Move the cursor to [HOME].
7. Push down (g) the jog dial to switch the monitor to the normal screen.  
The normal screen displays the consumption graph (A).



## [2. MACHINE FAMILIARIZATION]

### LANGUAGE SELECTION



This menu allows you to set the language displayed on the monitor.

#### Jog dial operation

##### Tilting (a,b,c,d) and rotating (e,f) the jog dial

To move the cursor on the monitor and adjust the values and others.

##### Pushing down (g) the jog dial

- To switch the screen to the selected setting screen.
- To determine the adjusted value and others.

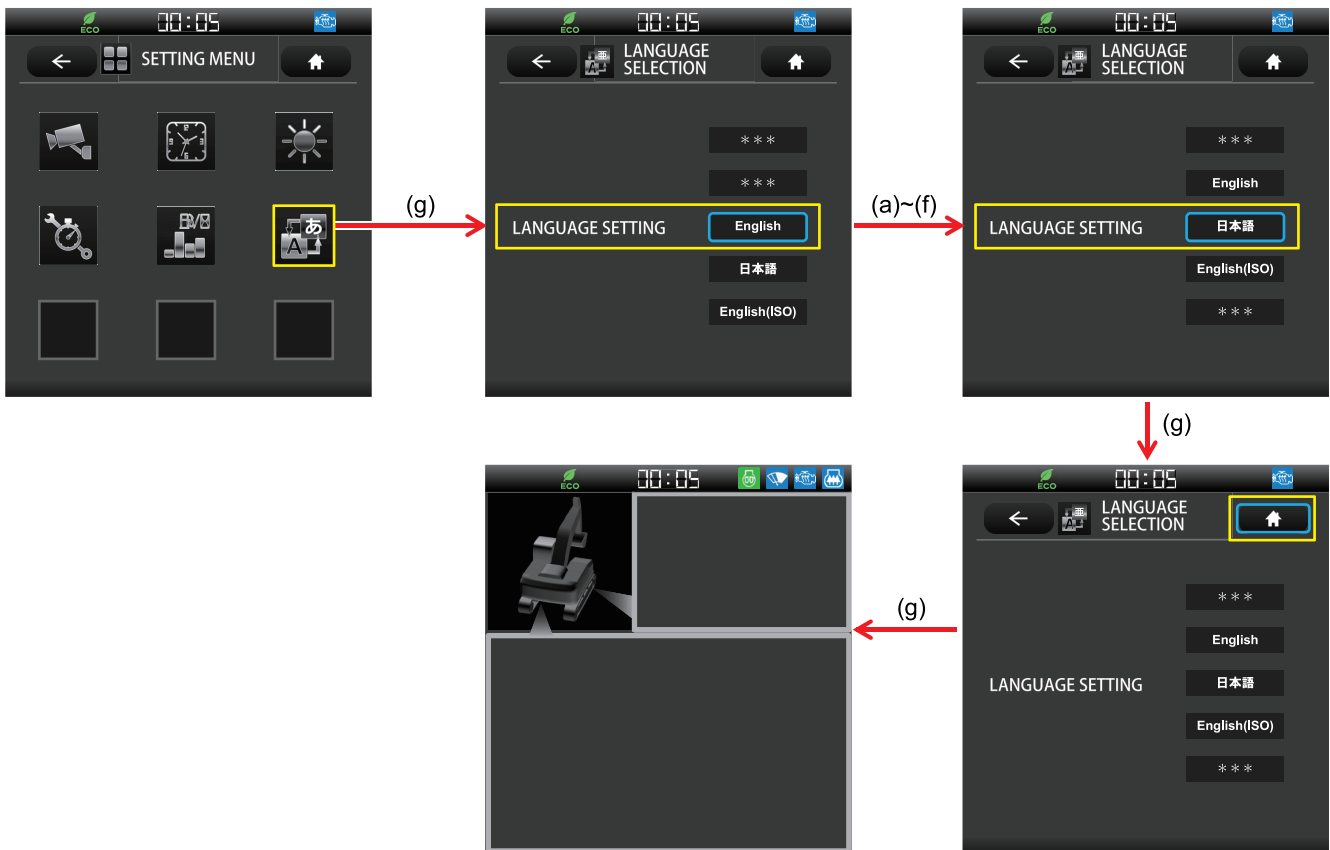
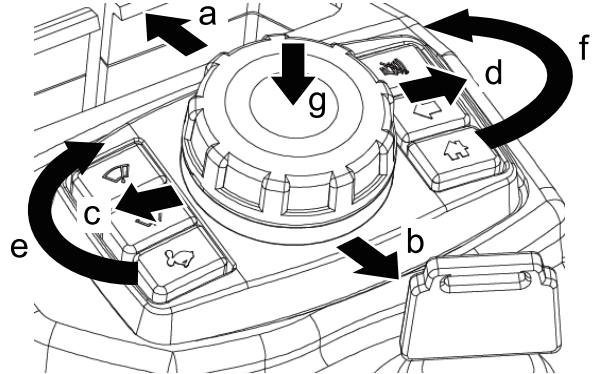

1. Switch the monitor to the [SETTING MENU] screen.
2. Tilt and turn the jog dial to move the cursor to [LANGUAGE SELECTION] on the [SETTING MENU] screen.
3. Push down (g) the jog dial to switch the monitor to the [LANGUAGE SELECTION] screen.
4. Tilt and turn the jog dial to move the cursor to [LANGUAGE SETTING].
5. Push down (g) the jog dial to enable the language to be selectable.
6. Tilt and turn the jog dial to select a desired language.
7. Push down (g) the jog dial to set the selected language.
8. Move the cursor to [HOME]
9. Push down (g) the jog dial to return the monitor to the [SETTING MENU] screen.



## PRESSURE RELEASE



This menu allows you to release the internal pressure of the hydraulic circuit.

See "RELEASING INTERNAL PRESSURE IN HYDRAULIC SYSTEM" in Chapter 4 in the operation & maintenance manual for details.

**Jog dial operation****Tilting (a,b,c,d) and rotating (e,f) the jog dial**

To move the cursor on the monitor and adjust the values and others.

**Pushing down (g) the jog dial**

- To switch the screen to the selected setting screen.
- To determine the adjusted value and others.

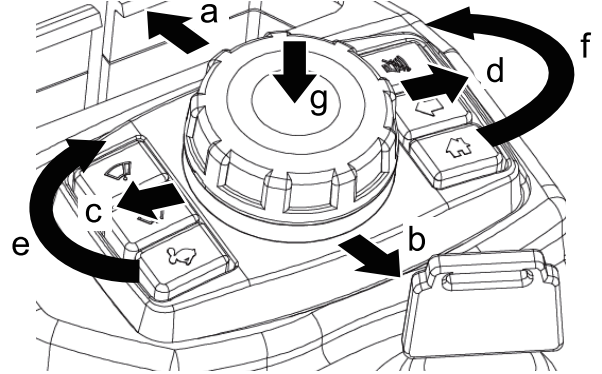

2



1. Switch the monitor to the [SETTING MENU] screen.
2. Tilt and turn the jog dial to move the cursor to [PRESSURE RELEASE] on the [SETTING MENU] screen.
3. Push down (g) the jog dial to set the machine to the pressure release mode.

## 2.3.10 SWITCH SETTING SCREEN

### Notice

When the control lock lever is raised upward to the locked(up) position, setting for changing the screen becomes possible.

### Jog dial operation

#### Tilting (a,b,c,d) and rotating (e,f) the jog dial

To move the cursor on the monitor and adjust the values and others.

#### Pushing down (g) the jog dial

- To switch the screen to the selected setting screen.
- To determine the adjusted value and others.

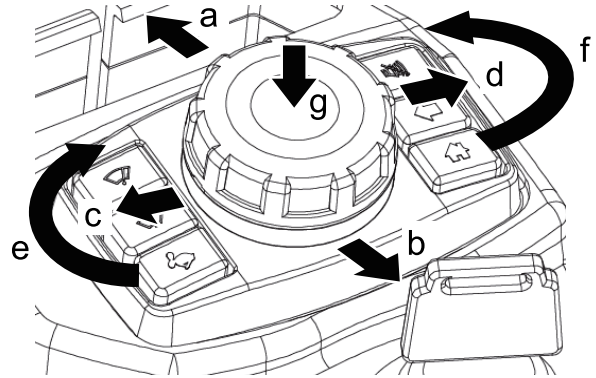

1. Tilt and turn the jog dial to move the cursor to switch setting (6) on the monitor.
2. Push down (g) the jog dial to switch the monitor to the [SWITCH SETTING] screen.

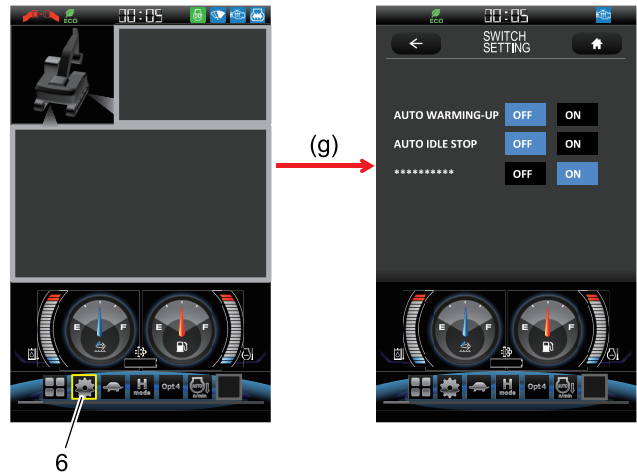

### Auto warming up setting

### CAUTION

- Do not leave the operator's seat during automatic warming-up.
- The attachment/equipment may slowly move to the internal direction but this is not failure. Check that the surroundings are clear of people and objects for avoiding being caught between the attachment/equipment and the machine, or interfered with the attachment/equipment.

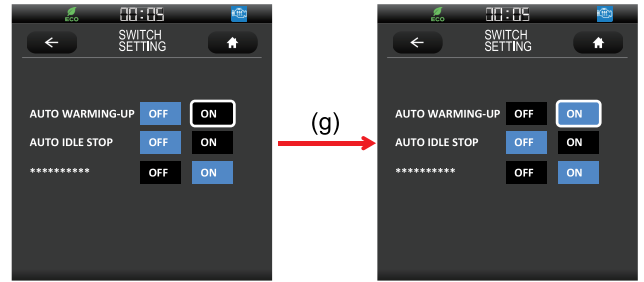
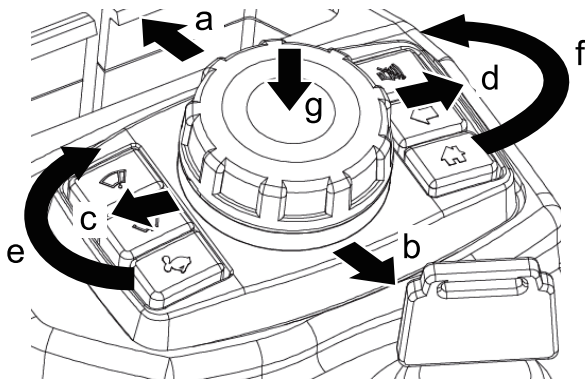

1. Tilt and turn the jog dial to move the cursor to [ON] of [AUTO WARMING-UP].
2. Push down (g) the jog dial to switch the setting to [ON].
3. Turn "OFF" the starter key switch once to store the setting.

#### Notice

Once "AUTO WARM-UP/ON" is set, there is no need to set it again.

4. Pull up the control lock lever to the "LOCKED" position.
5. When the engine is started in cold condition, auto warming-up starts. During warming-up of the hydraulic oil, the icon is indicated on the monitor.



#### Notice

- If "AUTO WARM-UP" is changed to [OFF] during hydraulic oil warming-up, the warming-up operation is forced to stop.
- In the hydraulic oil warming-up, if the control lever is operated, the warming-up operation is interrupted tentatively. Then the warming-up operation starts again, if the neutral lever condition continues for about 10 seconds.
- When the engine coolant temperature goes down, the automatic warming-up may start.

6. After the warming-up operation, "WARM-UP FINISHED" is displayed and the buzzer sounds for 5 seconds to tell the completion of the warming-up operation.

## [2. MACHINE FAMILIARIZATION]

### Setting of auto idle stop

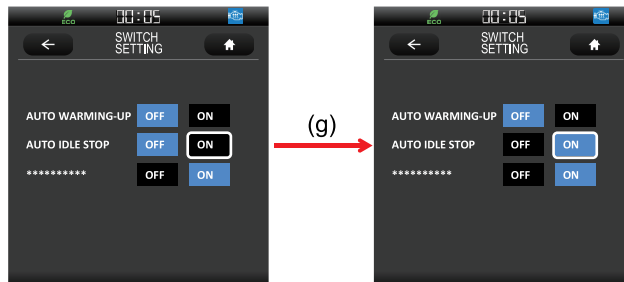
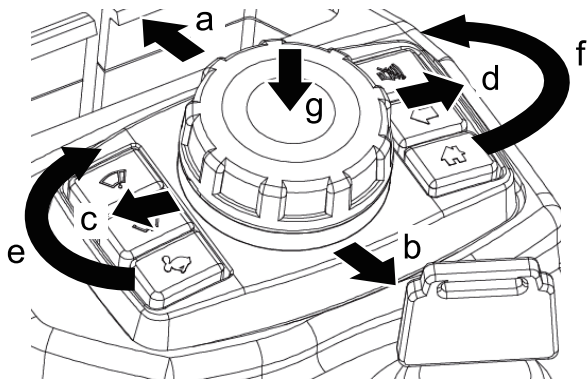

1. Tilt and turn the jog dial to move the cursor to [ON] of [AUTO IDLE STOP].
2. Push down (g) the jog dial to switch the setting to [ON].
3. Turn "OFF" the starter key switch once to store the status.
4. After the starter switch is turned "ON", the icon is displayed on the monitor.



2.3.11 TRAVEL SPEED SELECTION



ABOUT TRAVEL SPEED

The travel speed should be set to the LOW (1st) speed when the machine is traveling on a downhill, or being loaded to/unloaded from a trailer. A sudden change of the machine stability could cause personal injury.

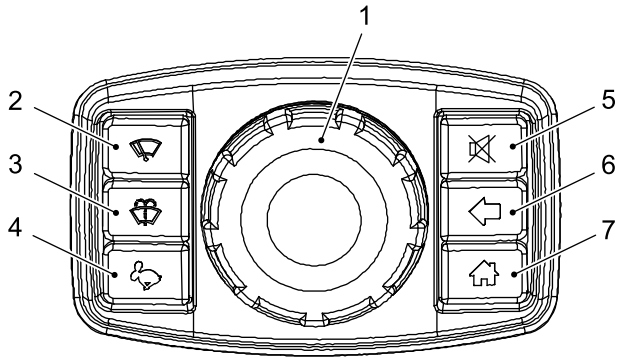

Each time the engine is started, the travel speed is automatically set to the LOW 1st (turtle) speed. Press switch (4) on the control panel and then the travel speed changes to the HIGH (2nd) speed and the icon displayed on the monitor changes to the HIGH (2nd) speed (rabbit).

LOW 1st speed: turtle



Set to LOW 1st speed when moving the machine on the rough or soft ground, slope, or in the narrow place, or when powerful tractive force is required.

HIGH 2nd speed: rabbit



Set to HIGH 2nd speed when moving the machine on a level and firm ground.

**Notice**

The HIGH (2nd) speed is automatically switched to the LOW (1st) speed when the load of traveling becomes high and automatically returned to the HIGH (2nd) speed when the load is lowered.



## 2.3.12 WORK MODE SELECTION

### Jog dial operation

#### Tilting (a,b,c,d) and rotating (e,f) the jog dial

To move the cursor on the monitor and adjust the values and others.

#### Pushing down (g) the jog dial

- To switch the screen to the selected setting screen.
- To determine the adjusted value and others.

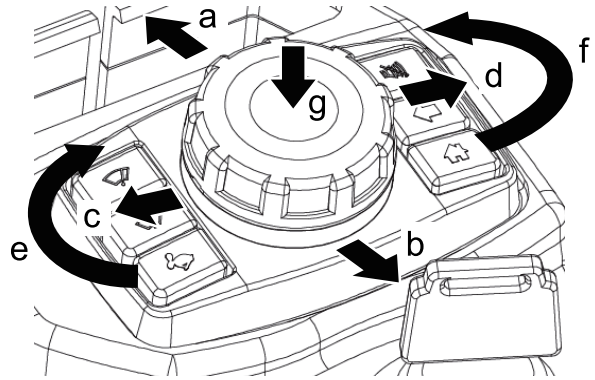

Select a proper work mode from three modes shown below according to the work condition and purpose. Move the cursor to [work mode selection] (8) and push down (g) the jog dial to switch the mode.

#### S mode:

"S mode" is suitable for a standard digging work and loading operations. It provides good fuel consumption and is well-balanced with a workload.

#### ECO mode:

"ECO mode" focuses on reduced fuel consumption operation.

#### H mode:



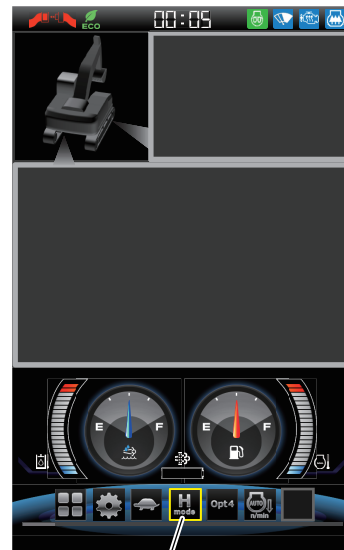



"H mode" is suitable for a heavy digging work, which provides high speed and gives priority to a workload.



Before beginning the work, make sure the selected work mode is correct.

### 2.3.13 SWITCHING ATTACHMENT MODE

Select an appropriate mode to use according to the attachment installed.

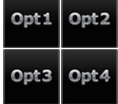
Display	Attachment mode	Summary
	Bucket	This mode needs to be selected for digging work.
	Breaker	This mode needs to be selected when an attachment using a single flow circuit such as a breaker is installed.
	Nibbler (crusher)	This mode needs to be selected when a hydraulic crusher such as a nibbler is installed.
	Rotary grapple	This mode is designed considering the operation such as a grapple.
	Processor	This mode is designed considering the operation such as a processor.
	Thumb bucket	This mode is designed considering the operation such as a thumb bucket.
	Rotary tilt	This mode is designed considering the operation such as a rotary tilt.
	Individual setting	This mode can be customized for an attachment other than those mentioned above.

#### CAUTION

- When the attachment mode is inappropriate, select a proper attachment mode.
- Always select the breaker mode when operating a breaker. Working in a mode other than the breaker mode causes damages to the hydraulic components and/or the breaker.
- Be sure to lower the attachment to the ground and ensure safety before switching the attachment mode.

#### Notice

- If tuning of operability is needed, contact your KOBELCO authorized dealer.
- When the control lock lever is raised upward to the "LOCKED" position, setting for changing the screen becomes possible.

## [2. MACHINE FAMILIARIZATION]

### ATTACHMENT MODE SELECTION

#### Jog dial operation

##### Tilting (a,b,c,d) and rotating (e,f) the jog dial

To move the cursor on the monitor and adjust the values and others.

##### Pushing down (g) the jog dial

- To switch the screen to the selected setting screen.
- To determine the adjusted value and others.

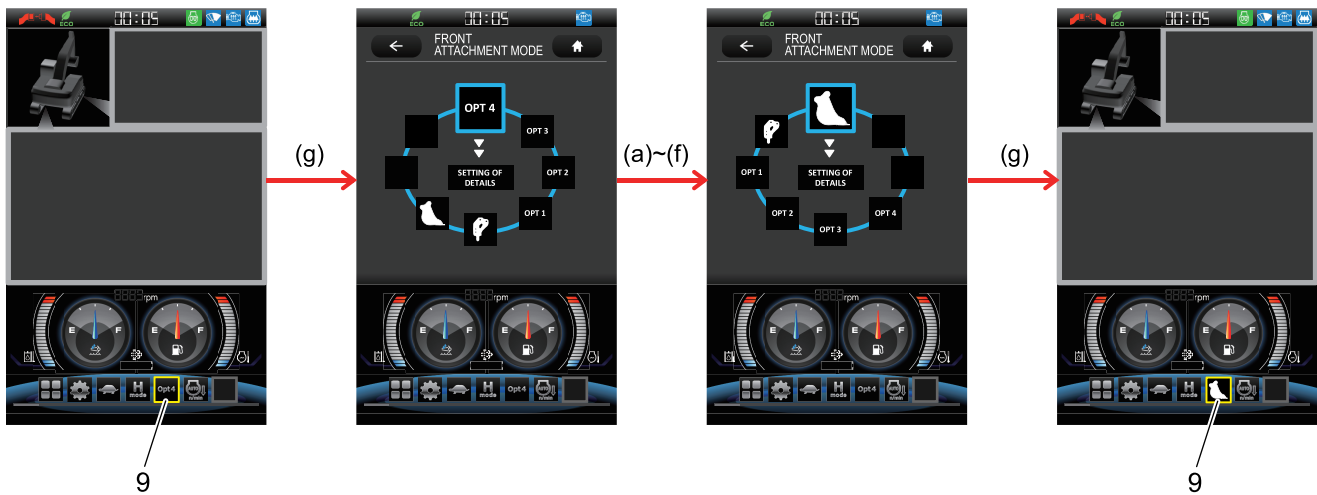
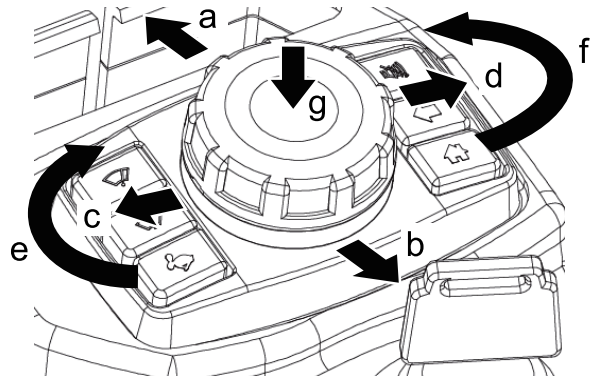

1. Tilt and turn the jog dial to move the cursor to attachment mode selection (9) on the monitor.
2. Push down (g) the jog dial to switch the monitor to the [FRONT ATTACHMENT MODE] screen.
3. Tilt and turn the jog dial to move the cursor to the icon of the front attachment being installed.
4. Push down (g) the jog dial to switch the icon of attachment mode selection (9) to the icon of the selected attachment.



## SETTING OF ATTACHMENT MODE DETAILS

**Notice**

Adjust them to a proper set value matching with an attachment to be used.

## Flow rate adjustment

**Jog dial operation****Tilting (a,b,c,d) and rotating (e,f) the jog dial**

To move the cursor on the monitor and adjust the values and others.

**Pushing down (g) the jog dial**

- To switch the screen to the selected setting screen.
- To determine the adjusted value and others.

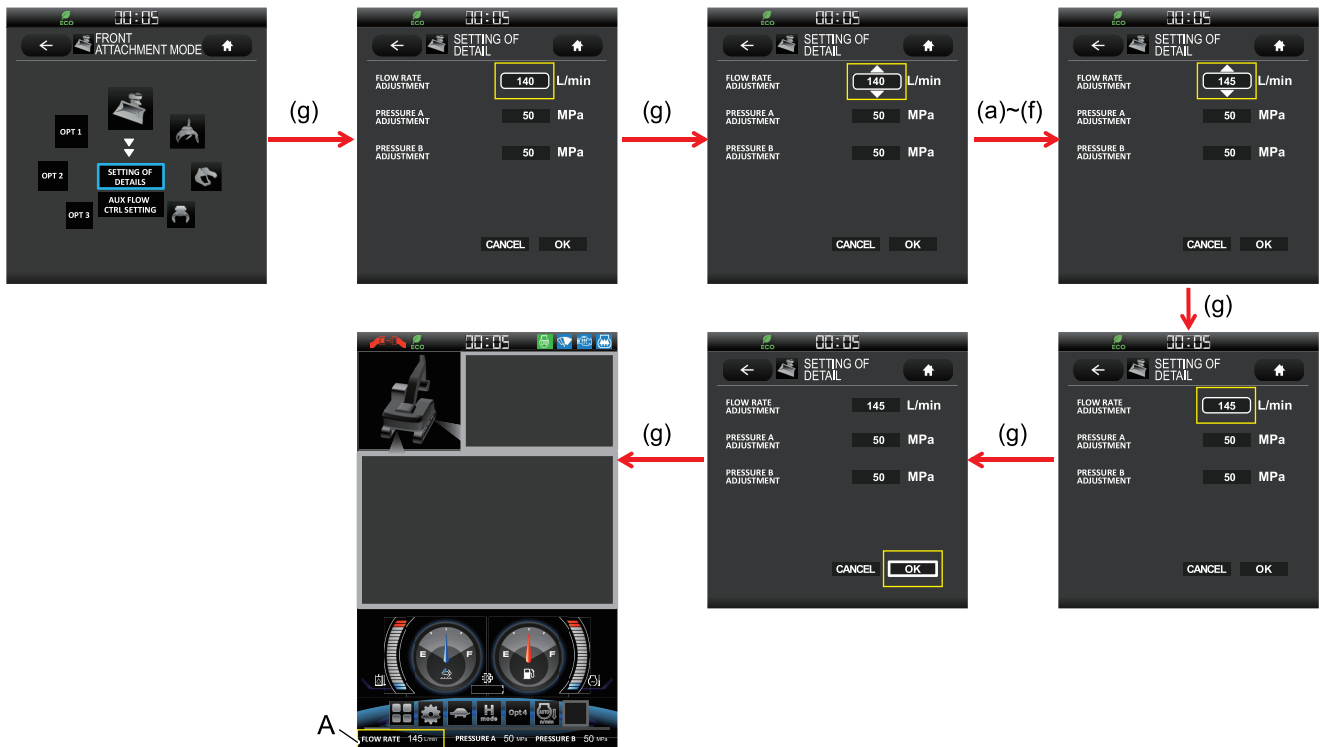
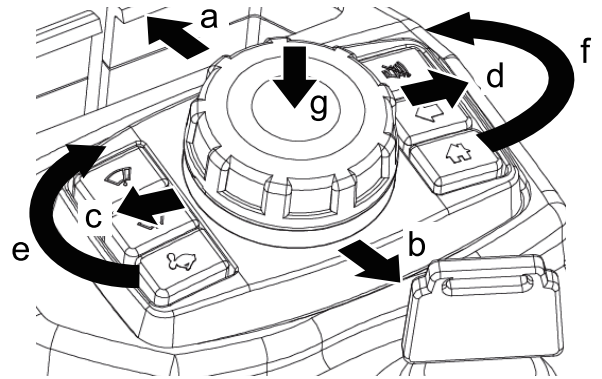

1. Move the cursor to [SETTING OF DETAIL] of the selected icon.
2. Push down (g) the jog dial to switch the monitor to the [SETTING OF DETAIL] screen.
3. Tilt and turn the jog dial to move the cursor to [FLOW RATE ADJUSTMENT].
4. Push down (g) the jog dial to enable the flow rate to be adjustable.
5. Tilt and turn the jog dial to a desired value.
6. Push down (g) the jog dial to set the desired flow rate.
7. Tilt and turn the jog dial to move the cursor to [OK].
8. Push down (g) the jog dial to return the monitor to the normal screen.  
Set value (A) is displayed on the lower side of the screen.

## [2. MACHINE FAMILIARIZATION]

### PRESSURE ADJUSTMENT

#### Notice

For some machines and specifications, the pressure B adjustment is only available.

#### Jog dial operation

##### Tilting (a,b,c,d) and rotating (e,f) the jog dial

To move the cursor on the monitor and adjust the values and others.

##### Pushing down (g) the jog dial

- To switch the screen to the selected setting screen.
- To determine the adjusted value and others.

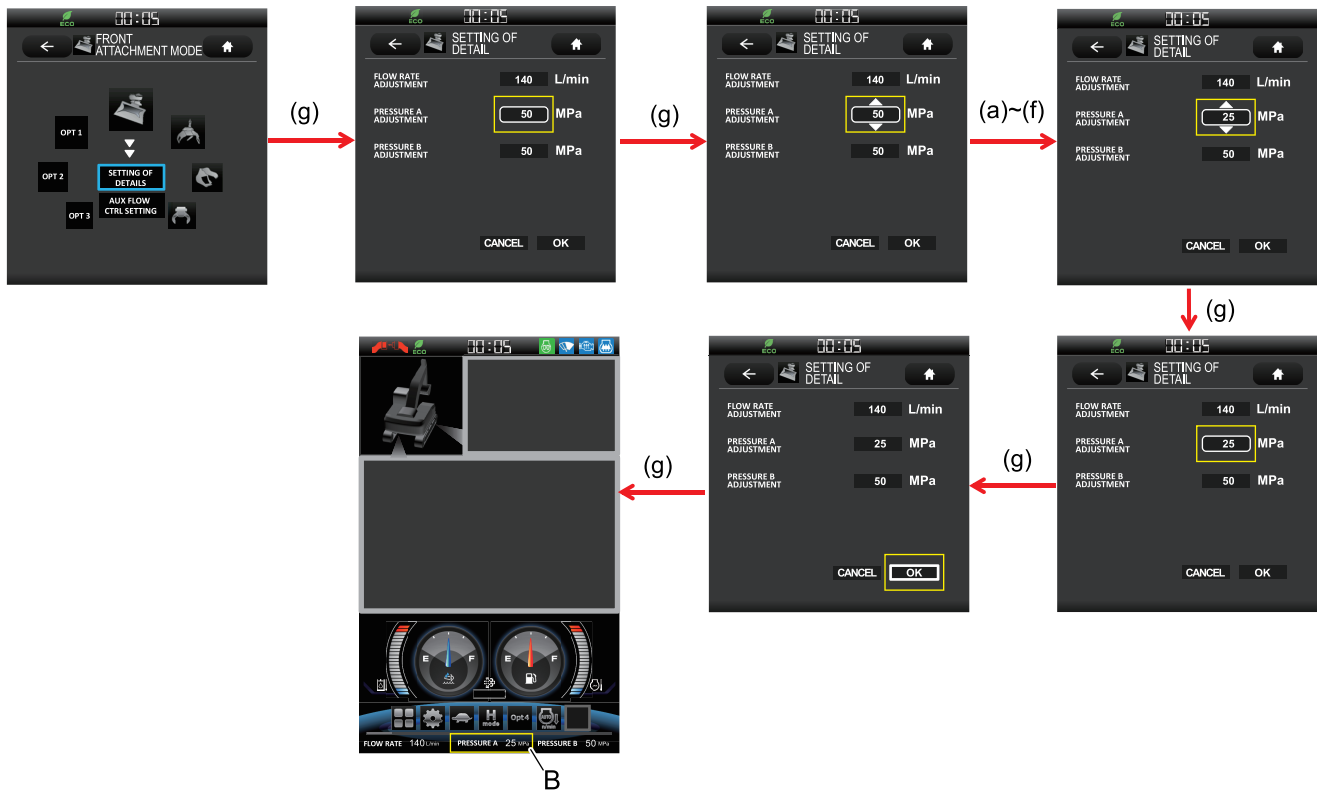
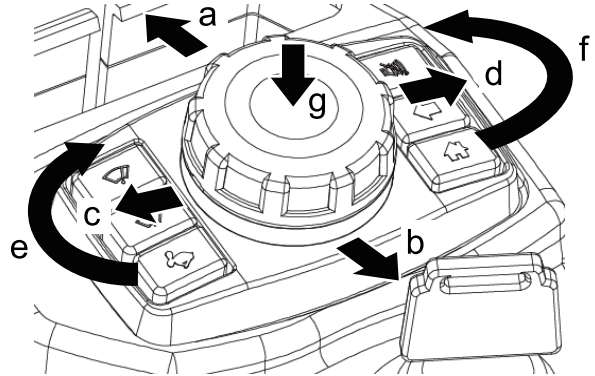

1. Move the cursor to [SETTING OF DETAIL] of the selected icon.
2. Push down (g) the jog dial to switch the monitor to the [SETTING OF DETAIL] screen.
3. Tilt and turn the jog dial to move the cursor to [PRESSURE A ADJUSTMENT] or [PRESSURE B ADJUSTMENT].
4. Push down (g) the jog dial to enable the flow rate to be adjustable.

5. Push down the control lock lever to "UNLOCKED" position (B).
6. Operate the subject front attachment for adjustment to perform relief operation.  
If it is not operated, "0" is displayed.
7. Tilt and turn the jog dial to a desired value.
8. Push down (g) the jog dial to set the desired pressure.
9. Tilt and turn the jog dial to move the cursor to [OK].
10. Push down (g) the jog dial to return the monitor to the normal screen.  
Set value (B) is displayed on the lower side of the screen.

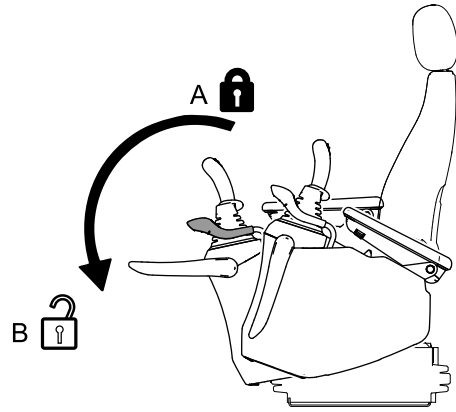

## [2. MACHINE FAMILIARIZATION]

### SETTING LIMIT OF AUX FLOW RATE OF ATTACHMENT MODE (ROTARY TILT)

#### Jog dial operation

##### Tilting (a,b,c,d) and rotating (e,f) the jog dial

To move the cursor on the monitor and adjust the values and others.

##### Pushing down (g) the jog dial

- To switch the screen to the selected setting screen.
- To determine the adjusted value and others.

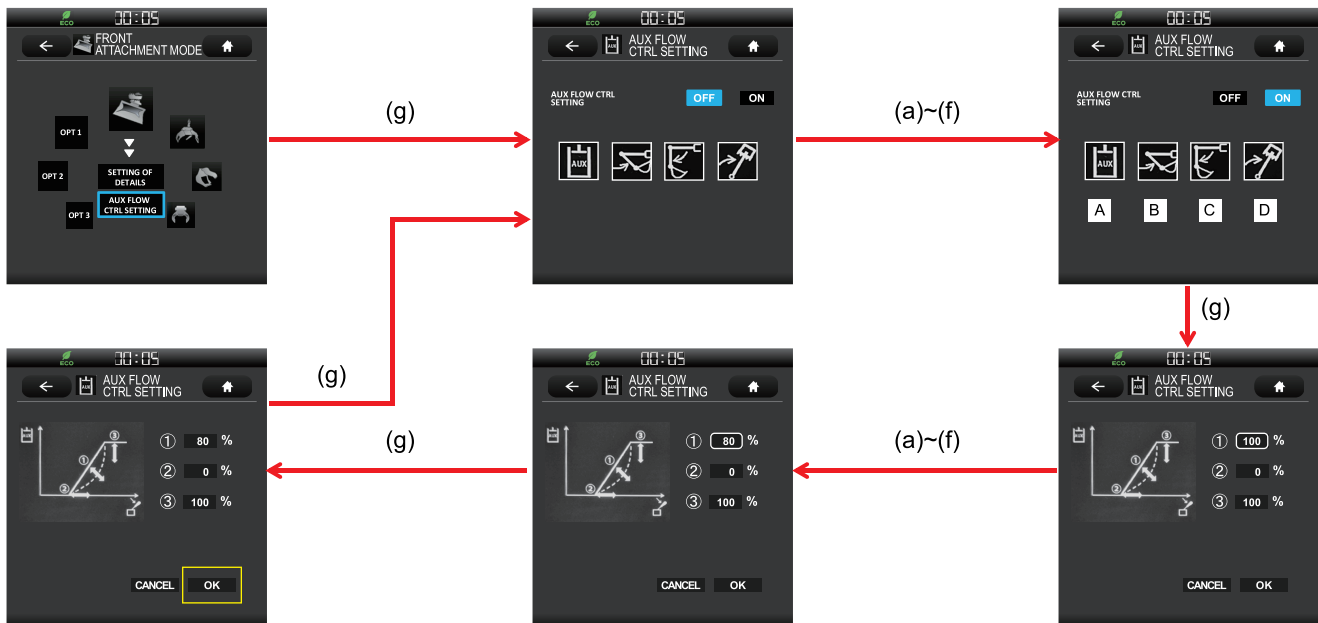
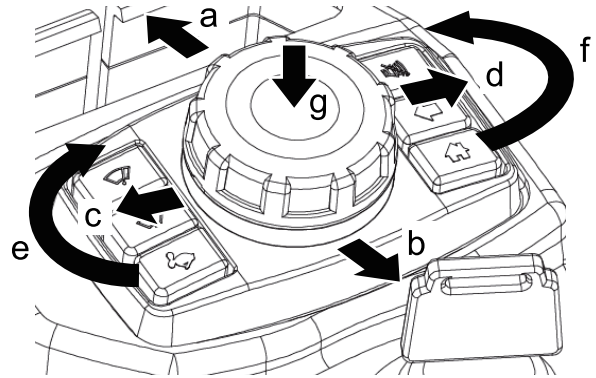

1. Move the cursor to [AUX FLOW CTRL SETTING] of the icon of the rotary tilt mode.
2. Push down (g) the jog dial to switch the monitor to the [AUX FLOW CTRL SETTING] screen.
3. Move the cursor to [ON] of [AUX FLOW CTRL SETTING].
4. Push down (g) the jog dial to switch the setting to [ON].
5. Tilt and turn the jog dial to move the cursor to a desired item to set.
6. Push down (g) the jog dial to enable the selected item to be adjustable.

Item	Adjusting operation pattern	Item possible to be adjusted *
A	Independent operation of rotary tilt	(1), (2)*, (3)*
B	Rotary tilt + arm in combined operation	(1)
C	Rotary tilt + arm out combined operation	(1)
D	Rotary tilt + swinging combined operation	(1)

#### Notice

\*(2) and (3) can be adjusted only at item A but the adjusted value affects the operability of items B, C, and D.

7. Tilt and turn the jog dial to a desired value.

Item	Adjusting item	Function
(1)	Transient property	Adjusts the flow rate increment per unit time (reaction ability for operation) when the attachment for adjustment is operated.
(2)	Starting point	Adjusts the lever displacement until the attachment starts moving.
(3)	Maximum flow rate	Adjusts the limit of the maximum flow rate when the control lever is operated.

8. Push down (g) the jog dial to set the desired value.
9. Tilt and turn the jog dial to move the cursor to [OK].
10. Push down (g) the jog dial to return the monitor to the [AUX FLOW CTRL SETTING] screen.

### 2.3.14 AUTO ACCELERATION ON/OFF SELECTION



#### WARNING Loading/unloading the machine

When loading or unloading the machine on a trailer, turn the auto acceleration switch off. If it is operated while the acceleration switch is on, the engine speed changes suddenly.

#### Jog dial operation

##### Tilting (a,b,c,d) and rotating (e,f) the jog dial

To move the cursor on the monitor and adjust the values and others.

##### Pushing down (g) the jog dial

- To switch the screen to the selected setting screen.
- To determine the adjusted value and others.

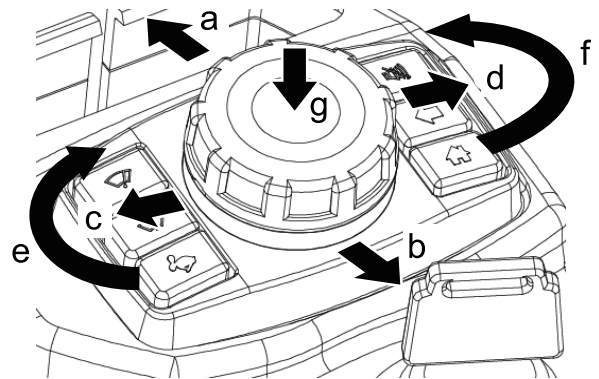

Move the cursor to auto acceleration (9) and push down (g) the jog dial to turn [ON] and actuate the auto acceleration.

When the jog dial is pushed down (g) again, it becomes [OFF] and then the auto acceleration is canceled. It sets the engine speed to low under the following conditions.

- When the acceleration dial position is set at a higher value than the range of the idle speed.
- When the control levers and/or pedals are not operated for 4 seconds or more.

When the control levers and/or pedals are operated, the engine speed rises back to the set level of the acceleration dial gradually according to the amount of operation of the lever and/or pedals.

If the switch (9) is pressed to turnoff during the auto acceleration operation, the engine speed rises back to the set level of the acceleration dial gradually.

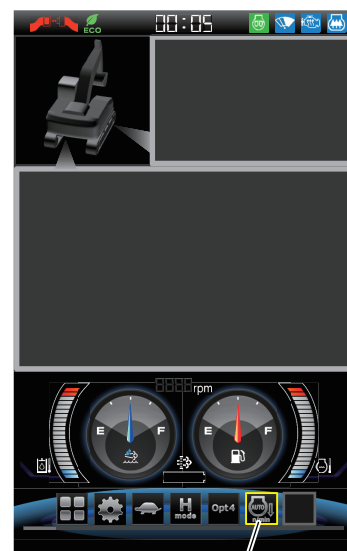

9

#### Notice

After key OFF, even if the machine is restarted, the setting is stored.

### 2.3.15 WIPER SWITCH

Push switch (2) to actuate the wiper of the front window.

Within 10 seconds after pushing switch (2), operate jog dial (1) and select a desired function.

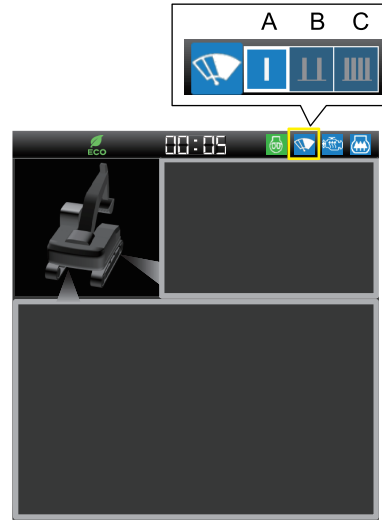
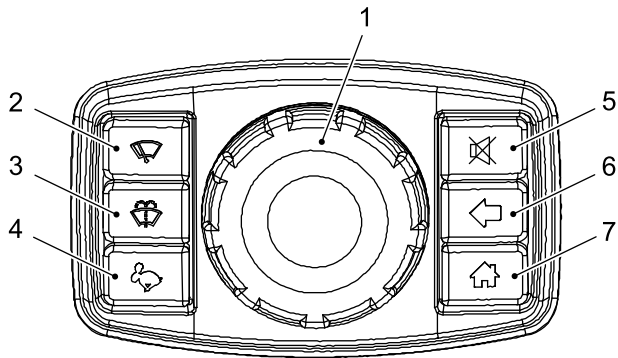

Symbol	Function
A	The wiper works one time.
B	The wiper works intermittently.
C	The wiper works continuously.

If switch (2) is pushed one more again, the wiper stops.

### 2.3.16 WASHER SWITCH

While switch (3) is being pressed, the washer fluid is sprayed through the nozzle of front window.

The washer fluid reservoir is located under the floor plate inside the cab.

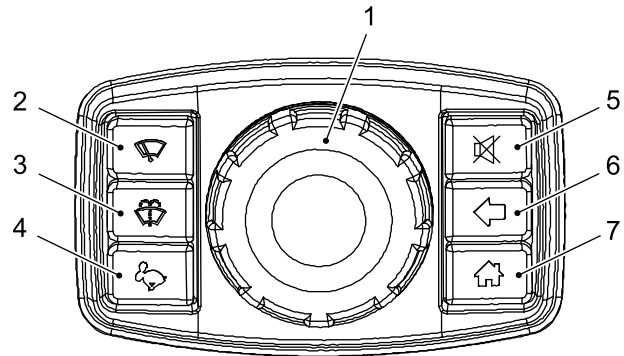

**Notice**

Make sure that the washer reservoir is filled with the washer fluid before operating the washer.

### 2.3.17 BUZZER STOP SWITCH

When warning (a) is displayed on the monitor and the buzzer sounds, press buzzer stop switch (5) to stop the buzzer of the items shown in the table.

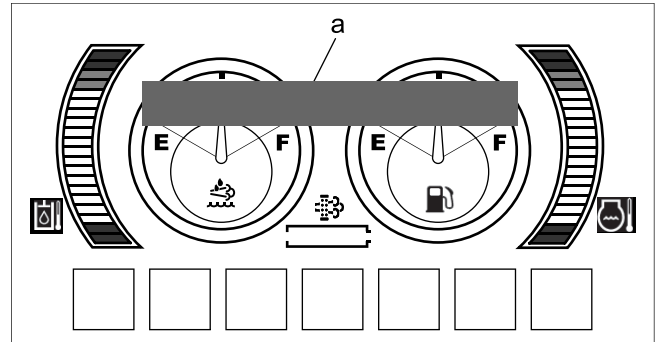
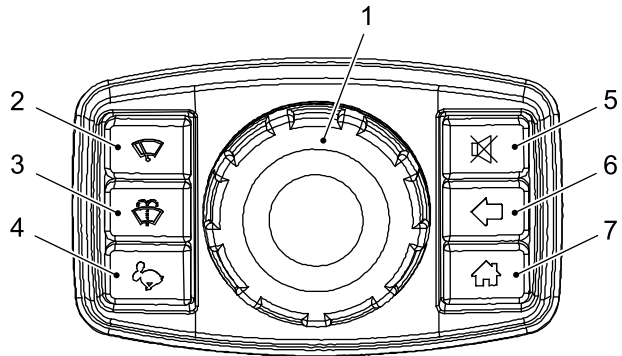

#### Items in the Warning Display Lists

##### Warning Level and Its Description

Level	Description
1	This is largely-concerned with the safety and machine movement. Stop the machine immediately and perform inspection and maintenance.
2	This notifies of the mode change of the machine.
3	This may lead to the failure of the machine. Immediately perform inspection and maintenance.
4	Difficulty may occur in working. Immediately perform inspection and maintenance.
5	This notifies of the machine status and maintenance.

##### Buzzer sound type

Buzzer sound type	Sounds
Type 1	Continuous
Type 2	Sound 0.2 seconds, stop 0.3 seconds
Type 3	Sound 0.5 seconds, stop 0.5 seconds













##### Priority Group A

Level	Display	Warning Details	Buzzer				
			Auto Stop	Manual Stop	Type	Starter Key ON	Engine Running
1	CPU DATA COMMUNICATION ERROR	Mechatro Controller does not send data.	Unavailable	Available	3	○	○
1	SWING BRAKE DISENGAGED	The swing parking brake release switch is switched to the "RELEASE LOCK" position.	Available (5 sec.)	Available	2	○	○
1	ENGINE STOP	An emergency stop is performed due to low engine oil pressure.	Available (5 sec.)	Unavailable	1	○	—



## [2. MACHINE FAMILIARIZATION]

### Priority Group B

Level	Display	Warning Details	Buzzer				
			Auto Stop	Manual Stop	Type	Starter Key ON	Engine Running
1	 NIBBLER AND BREAKER SWITCHING FAILURE PARK AND REPAIR MACHINE	Displayed when the selector valve malfunctions.	Unavailable	Available	2	—	○
1	 POOR DEF/ADBLUE QUALITY DETECTED  EXTREME POWER LIMITATION IN PROGRESS	Displayed when the DEF/AdBlue sensor detects the quality failure of DEF/AdBlue, and the machine becomes inoperable.	Unavailable	Unavailable	1	○	○
1	 DEF/ADBLUE TANK IS EMPTY  EXTREME POWER LIMITATION IN PROGRESS	Displayed when the DEF/AdBlue level gauge shows Level 0 (no display), and the machine becomes inoperable.	Unavailable	Unavailable	1	○	○
1	 NOx CONTROL SYSTEM FAILURE  EXTREME POWER LIMITATION IN PROGRESS P204F	Displayed when each device and sensor of NOx discharge control system fails or becomes abnormal, and the machine becomes inoperable. (The failure code is an example)	Unavailable	Unavailable	1	○	○
1	 DEF/ADBLUE INJECTION FAILURE  EXTREME POWER LIMITATION IN PROGRESS P204F	Displayed when the DEF/AdBlue dosing module fails or becomes abnormal, and the machine becomes inoperable. (The failure code is an example)	Unavailable	Unavailable	1	○	○
1	 EGR VALVE FAILURE  EXTREME POWER LIMITATION IN PROGRESS P1459	Displayed when the EGR valve fails or becomes abnormal, and the machine becomes inoperable. (The failure code is an example)	Unavailable	Unavailable	1	○	○
2	WARM FINISH WARM-UP	Displayed when automatic warming-up is done.	Available (5 seconds)	Unavailable	2	—	○
2	 1. LIFT UP LOCK LEVER 2. PUSH REGENERATION SW.	Displayed when regeneration of the exhaust gas cleaning device is required.	Unavailable	Available	3	—	○



Level	Display	Warning Details	Buzzer				
			Auto Stop	Manual Stop	Type	Starter Key ON	Engine Running
2	POOR DEF/ADBLUE QUALITY DETECTED POWER LIMITATION IN PROGRESS	Displayed when the DEF/AdBlue sensor detects the quality failure of DEF/AdBlue, and the engine output is limited.	Unavailable	Unavailable	2	○	○
2	DEF/ADBLUE LEVEL LOW POWER LIMITATION IN PROGRESS	Displayed when the DEF/AdBlue level gauge becomes Level 1 (Red), and the engine output is limited.	Unavailable	Unavailable	2	○	○
2	NOx CONTROL SYSTEM FAILURE POWER LIMITATION IN PROGRESS P204F	Displayed when each device and sensor of the NOx discharge control system fails or becomes abnormal, and the engine output is limited. (The failure code is an example)	Unavailable	Unavailable	2	○	○
2	DEF/ADBLUE INJECTION FAILURE POWER LIMITATION IN PROGRESS P204F	Displayed when the DEF/AdBlue dosing module fails or becomes abnormal, and the engine output is limited. (The failure code is an example)	Unavailable	Unavailable	2	○	○
2	EGR VALVE FAILURE POWER LIMITATION IN PROGRESS P1459	Displayed when the EGR valve fails or becomes abnormal, and the engine output is limited. (The failure code is an example)	Unavailable	Unavailable	2	○	○
2	NOx CONTROL SYSTEM FAILURE TORQUE LIMITATION IN PROGRESS P204F	Displayed when each device of NOx discharge control system or sensor fails or becomes abnormal, and the engine output is limited. (The failure code is an example)	Unavailable	Available	3	○	○
2	DEF/ADBLUE INJECTION FAILURE TORQUE LIMITATION IN PROGRESS P204F	Displayed when the DEF/AdBlue dosing module fails or becomes abnormal, and the engine output is limited. (The failure code is an example)	Unavailable	Available	3	○	○
2	EGR VALVE FAILURE TORQUE LIMITATION IN PROGRESS P1459	Displayed when the EGR valve fails or becomes abnormal, and the engine output is limited. (The failure code is an exam)	Unavailable	Available	3	○	○
3	POOR DEF/ADBLUE QUALITY DETECTED	Displayed when the DEF/AdBlue sensor detects the quality failure of DEF/AdBlue.	Unavailable	Available	3	○	○
3	DEF/ADBLUE LEVEL LOW	Displayed when the DEF/AdBlue level gauge becomes Level 2 (Yellow).	Unavailable	Available	3→2※1	○	○
3	LOW ENG OIL PRESS.	Displayed when the engine oil pressure reduces, and disconnection is detected.	Unavailable	Available	2	○	○
3	COOLANT OVERHEATING	Displayed when the engine coolant temperature rises.	Unavailable	Available	3	○	○
3	CLOGGED AIR FLTR	Displayed when the air cleaner element is clogged.	Unavailable	Available	3	○	○
3	I113	Self-diagnosis (failure on the pressure sensor, or the proportional valve, etc.)	Unavailable	Available	3	○	○

2

## 2.3.18 WARNING DISPLAY SCREEN





### WHEN WARNINGS ARE DISPLAYED















A warning displayed on the multi-display may lead to severe trouble. Stop the operation immediately, investigate the causes and take proper measures.

- The warning display has the order of priority and when many troubles such as level 1 and 2 in priority (A) occurred at the same time, level 1 is displayed in priority to level 2.
- The start-up inspection should be performed according to not only the monitor but also the instructions in "MAINTENANCE".

### WARNING CLASSIFICATION CHART (PRIORITY A)

Display	Level	Warning Details	Required Actions
 CPU DATA COMMUNICATION ERROR	1	Mechatro Controller does not send data.	Contact your KOBELCO authorized dealer for inspection/maintenance.
 SWING BRAKE DISENGAGED	1	The swing parking brake release switch is switched to the "RELEASE LOCK" position.	
 ENGINE STOP	1	An emergency stop is performed due to low engine oil pressure.	



















**WARNING CLASSIFICATION CHART (PRIORITY B)**













Display	Level	Warning Details	Required Actions
 NIBBLER AND BREAKER SWITCHING FAILURE PARK AND REPAIR MACHINE	1	Displayed when the selector valve malfunctions.	The attachment installed to the crusher or breaker specification machine does not match the selected attachment mode. Select an appropriate attachment mode by switching the attachment mode select switch. Breaker mode: When using a breaker Nibbler mode: When using a nibbler (crusher) Even when an adequate operation mode is selected and the indication of selector failure does not disappear, contact and ask your KOBELCO authorized dealer for inspection/maintenance.
 POOR DEF/ADBLUE QUALITY DETECTED  EXTREME POWER LIMITATION IN PROGRESS	1	Displayed when DEF/AdBlue sensor detects the quality failure of DEF/AdBlue, and the machine becomes inoperable.	Refer to Chapter 3 "CHECKING DEF/AdBlue LEVEL AND REFILLING" and Chapter 4 "DRAINING DEF/AdBlue" to drain the contents of DEF/AdBlue tank, and refill DEF/AdBlue.
 DEF/ADBLUE TANK IS EMPTY  EXTREME POWER LIMITATION IN PROGRESS	1	Displayed when DEF/AdBlue level gauge becomes Level 0 (No display), and the machine becomes inoperable.	Refer to Chapter 3 "CHECKING DEF/AdBlue LEVEL AND REFILLING", and supply DEF/AdBlue until DEF/AdBlue level gauge becomes Level 3 (Green) or more.
 NOx CONTROL SYSTEM FAILURE  EXTREME POWER LIMITATION IN PROGRESS P204F	1	Displayed when each device and sensor of the NOx discharge control system fails or becomes abnormal, and the machine becomes inoperable. (The failure code is an example)	Contact your KOBELCO service shop.
 DEF/ADBLUE INJECTION FAILURE  EXTREME POWER LIMITATION IN PROGRESS P204F	1	Displayed when DEF/AdBlue injection device fails or becomes abnormal, and the machine becomes inoperable. (The failure code is an example)	
 EGR VALVE FAILURE  EXTREME POWER LIMITATION IN PROGRESS P1459	1	Displayed when the EGR valve fails or becomes abnormal, and the machine becomes inoperable. (The failure code is an example)	
 EXH. GAS DEGRADATION FAILURE: EXH. GAS P-CLNG DEV.  ENGINE REGENERATION REQUIRED	1	Displayed when the soot is deposited exceeding the specified value on the DPF.	Press the regeneration switch during machine operation according to the display of the gauge cluster to restore the DPF. Restoring the DPF is possible while performing normal operation. The restoring will be completed approximately in 50 minutes (according to the conditions, the time of completion will be changed). If the error is still displayed even after performing the above-mentioned procedure, contact our service factory.
WARM FINISH WARM-UP	2	Displayed when the automatic warming-up is done.	The warming-up operation of the engine and hydraulic oil are completed. Refer to "STARTING ENGINE" in "3. MACHINE OPERATION", and start the engine with proper procedures.
 1. LIFT UP LOCK LEVER 2. PUSH REGENERATION SW.	2	Displayed when regeneration of the exhaust gas cleaning device is required.	Refer to Chapter 4 "ABOUT MANUAL REGENERATION", and perform manual regeneration.
 REGEN. IS BEING CARRIED OUT HI TEMP. AROUND MUFFLER ※1	2	Displayed when regenerating the exhaust gas cleaning device.	Refer to Chapter 4 "ABOUT AUTOMATIC REGENERATION" and "ABOUT MANUAL REGENERATION". If manual regeneration is in progress, wait until the display turns off.

\*1: This mark is also displayed during machine operation, when occasional automatic soot combustion is performed.

See "ABOUT MANUAL REGENERATION" in Chapter 4.

## [2. MACHINE FAMILIARIZATION]

Display	Level	Warning Details	Required Actions
 <b>POOR DEF/ADBLUE QUALITY DETECTED</b>  <b>POWER LIMITATION IN PROGRESS</b>	2	Displayed when DEF/AdBlue sensor detects the quality failure of DEF/AdBlue, and the engine output is limited.	Refer to Chapter 3 "CHECKING DEF/AdBlue LEVEL AND REFILLING" and Chapter 4 "DRAINING DEF/AdBlue" to drain the contents of DEF/AdBlue tank, and refill DEF/AdBlue.  Refer to Chapter 3 "CHECKING DEF/AdBlue LEVEL AND REFILLING", and supply DEF/AdBlue until DEF/AdBlue level gauge becomes Level 3 (Green) or more.  Contact your KOBELCO service shop.
 <b>DEF/ADBLUE LEVEL LOW</b>  <b>POWER LIMITATION IN PROGRESS</b>	2	Displayed when DEF/AdBlue level gauge becomes Level 1 (Red), and the engine output is limited.	
 <b>NOx CONTROL SYSTEM FAILURE</b>  <b>POWER LIMITATION IN PROGRESS</b> <b>P204F</b>	2	Displayed when each device and sensor of the NOx discharge control system fails or becomes abnormal, and the engine output is limited. (The failure code is an example)	
 <b>DEF/ADBLUE INJECTION FAILURE</b>  <b>POWER LIMITATION IN PROGRESS</b> <b>P204F</b>	2	Displayed when the DEF/AdBlue dosing module fails or becomes abnormal, and the engine output is limited. (The failure code is an example)	
 <b>EGR VALVE FAILURE</b>  <b>POWER LIMITATION IN PROGRESS</b> <b>P1459</b>	2	Displayed when the EGR valve fails or becomes abnormal, and the engine output is limited. (The failure code is an example)	
 <b>NOx CONTROL SYSTEM FAILURE</b>  <b>TORQUE LIMITATION IN PROGRESS</b> <b>P204F</b>	2	Displayed when each device or sensor of NOx discharge control system fails or becomes abnormal, and the engine output is limited. (The failure code is an example).	
 <b>DEF/ADBLUE INJECTION FAILURE</b>  <b>TORQUE LIMITATION IN PROGRESS</b> <b>P204F</b>	2	Displayed when the DEF/AdBlue dosing module fails or becomes abnormal, and the engine output is limited. (The failure code is an example)	
 <b>EGR VALVE FAILURE</b>  <b>TORQUE LIMITATION IN PROGRESS</b> <b>P1459</b>	2	Displayed when the EGR valve fails or becomes abnormal, and the engine output is limited. (The failure code is an exam)	
 <b>POOR DEF/ADBLUE QUALITY DETECTED</b>	3	Displayed when DEF/AdBlue sensor detects the quality failure of DEF/AdBlue, and the engine output is limited.	
 <b>DEF/ADBLUE LEVEL LOW</b>	3	Displayed when DEF/AdBlue level gauge becomes Level 2 (Yellow).	

Display	Level	Warning Details	Required Actions
 LOW ENG OIL PRESS.	3	<ul style="list-style-type: none"> <li>- Displayed when the engine oil pressure is lower than a specified value, and the output reduction control is performed.</li> <li>- Displayed when a disconnection is detected.</li> </ul>	<ul style="list-style-type: none"> <li>- Stop the engine promptly, check the oil level, and disconnection place, and refill or replace the specified engine oil referring to "LUBRICANT, FUEL &amp; COOLANT SPECIFICATIONS", if required.</li> <li>- If this is displayed while engine stop, the wire may be disconnected, etc. Contact your KOBELCO authorized dealer for repair.</li> </ul>
 COOLANT OVERHEATING	3	Displayed when the coolant temperature exceeds a specified value.	Stop operation, and lower the engine speed to the low idle speed to cool the engine. When the warning display does not disappear after a few minutes, stop the engine, and check the coolant level, fan belt tension, and radiator clogging.
 CLOGGED AIR FLTR	3	Displayed when the engine output reduces due to a clogged intake air filter.	Check and clean the filter. If necessary, replace the filter.
I113	3	Error code is displayed when failure occurred in the pressure sensor, proportional valve, etc.	Ask your KOBELCO authorized dealer for inspection/maintenance.
 PUSH REGENERATION SW.	3	FAILURE: EXH.GAS P-CLNG DEV. (P2BA6) is displayed when an error occurs.	Press the regeneration switch according to the display during machine operation. For the detail actions, follow the contents described in the item of FAILURE: EXH.GAS P-CLNG DEV. (P2BA6).
 CHARGE ERROR	4	<p>Battery failure. (High voltage/low voltage/ insufficient charge)</p> <p>The battery is not charged adequately if the warning does not disappear after a while from the engine is started or if the warning is displayed while the engine is running.</p>	Check the usage condition of the electrical components and the charge circuit.
 LOW FUEL LEVEL	4	The fuel is below a specified quantity.	Refill the specified fuel.
 HIGH HYD. OIL TEMP.	5	Displayed when the temperature of hydraulic oil rises abnormally.	Stop operation, and ask your KOBELCO authorized dealer for inspection/maintenance.
WARM AUTO WARMING UP	5	Displayed during the automatic warming-up operation.	Automatic warming-up operation is being performed. Wait until "WARM FINISH WARM-UP" appears.
 CHANGE ENG OIL	5	The remaining time to the engine oil change becomes zero.	Refill the specified new engine oil with the specified quantity.
 LIFT UP LOCK LEVER BEFORE ENGINE START	5	Displayed when the key switch is turned to "START" position while the control lock lever is down.	Set the key switch back to "ON" position, and secure safety by raising the control lock lever. Turn the switch to "START" again to start the engine.
 CHANGE FUEL FLTR	5	Displayed when the remaining time to the fuel filter change becomes zero.	Replace with a specified new fuel filter.
 CHANGE HYD. OIL FLTR	5	Displayed when the remaining time to the hydraulic oil filter change becomes zero.	Replace with a specified new hydraulic oil filter.
 CHANGE HYD. OIL	5	Displayed when the remaining time to the hydraulic oil change becomes zero.	Replace with a specified new hydraulic oil.

### 2.3.19 CLOGGING DETECTOR OF HYDRAULIC OIL FILTER

Change the hydraulic oil filter when "CHANGE HYD.OIL FLTR" appears on the monitor. (See "REPLACING RETURN FILTER" in Chapter 4 for replacement procedures.)

---

**Note**

When the clogging detector of the hydraulic oil filter is working, the pump operation noise becomes louder for approximately 3 seconds with the control lever in the neutral position, but it is not abnormal.

---

1. To release the warning, set the maintenance interval of the return filter again from the monitor. (Default value: 1000 hrs.)  
(See "MAINTENANCE" in Chapter 2 for setting procedures.)



2. After the setting of 1. is completed, operate the machine for a while, then the warning is released automatically.

## 2.4 HANDLING OF SWITCHES AND METERS

### 2.4.1 STARTER SWITCH

This switch is used to start or stop the engine.

- OFF (STOP):  
At this position, you can insert or remove the starter key. Before restarting or stopping the engine, turn the starter key to the "OFF" position.
- ON:  
Electricity flows in all circuits. During operation, the starter key should be in this position.
- START:  
When starting the engine, turn the key to the "START" position. When the engine starts, release your hand from the starter switch. The starter key will return to the "ON" position by itself.

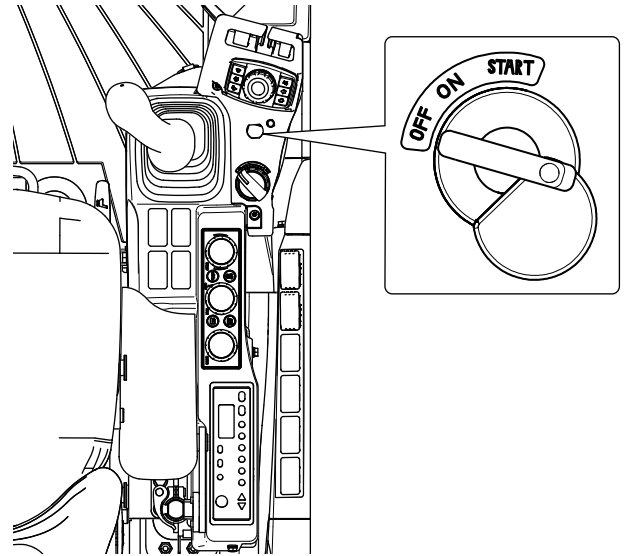

### 2.4.2 ENGINE THROTTLE

This dial adjusts the number of engine speed (output). This is a dial type rotary switch and a continuous adjustment type. If you release the dial at a rotated position, it stops at that position, and maintains assigned engine speed.

- LO (Low idle)  
The number of engine speed is minimum at the end of left rotation.
- H (High idle)  
The number of engine speed is maximum at the end of right rotation.

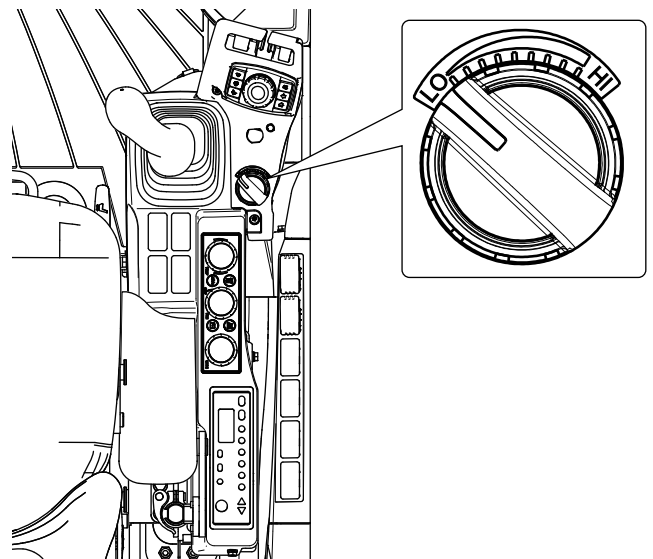

### 2.4.3 WORKING LIGHT (BOOM AND DECK)

Push the switch to turn on the working lights on the boom and deck .

Push the no symbol mark side to turn off the working lights on the boom and deck .

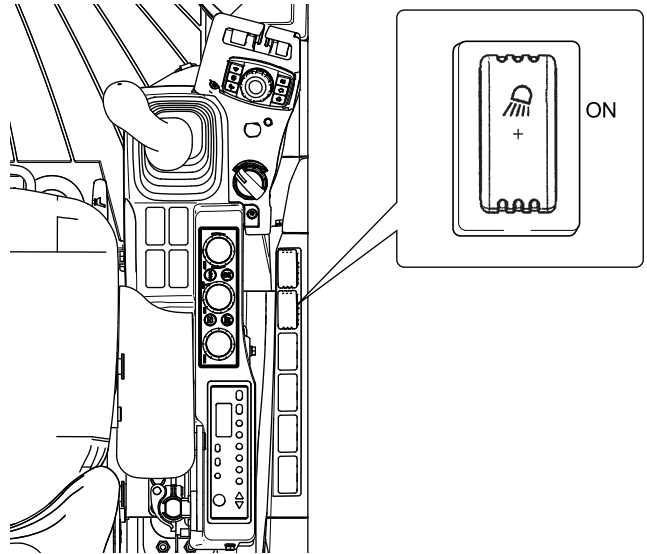

### 2.4.4 WORKING LIGHT SWITCH (CAB LIGHT)

Push the switch to turn on the working light of the cab.

Push the no symbol mark side to turn off the working light on the cab.

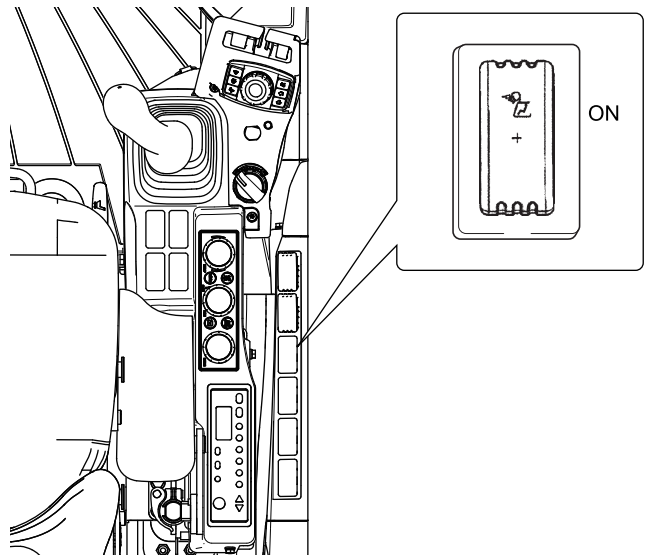

### 2.4.5 MANUAL REGENERATION SWITCH

When you press the manual regeneration switch, is regenerated.

For details, see "EXHAUST GAS CLEANING DEVICE (DOC)" in Chapter 4.

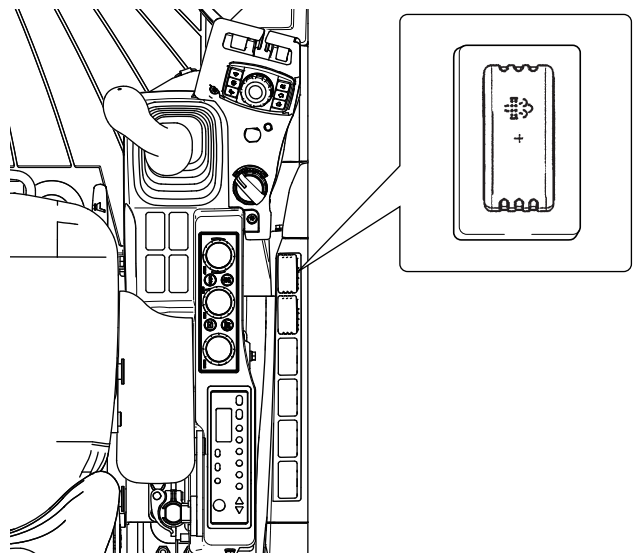



## 2.4.6 CAP (OPTION SWITCH)

This is a place to install an optional switch.

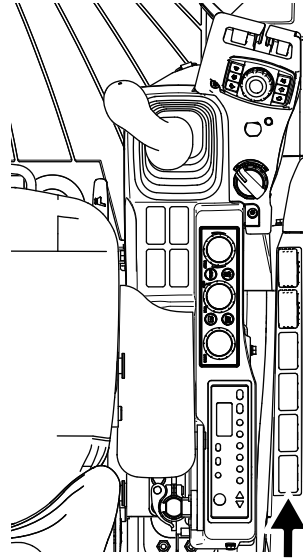

## 2.4.7 HORN SWITCH

### CAUTION

Be sure to sound the horn before starting this machine to warn surrounding personnel.

The horn sounds while the switch located on the top of the left control lever grip is being pressed.

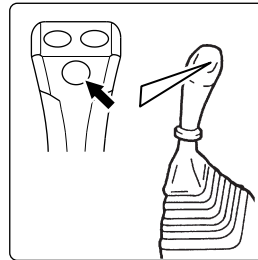

## 2.4.8 EMERGENCY ACCEL

This dial is used when the controller that controls this machine has trouble. When the engine speed cannot be adjusted with the engine throttle due to controller trouble, operate this emergency accel (1) to adjust the engine speed.

Under normal conditions, do not operate emergency accel (1).

When controller warning (2) is displayed on the monitor, contact your KOBELCO authorized dealer.

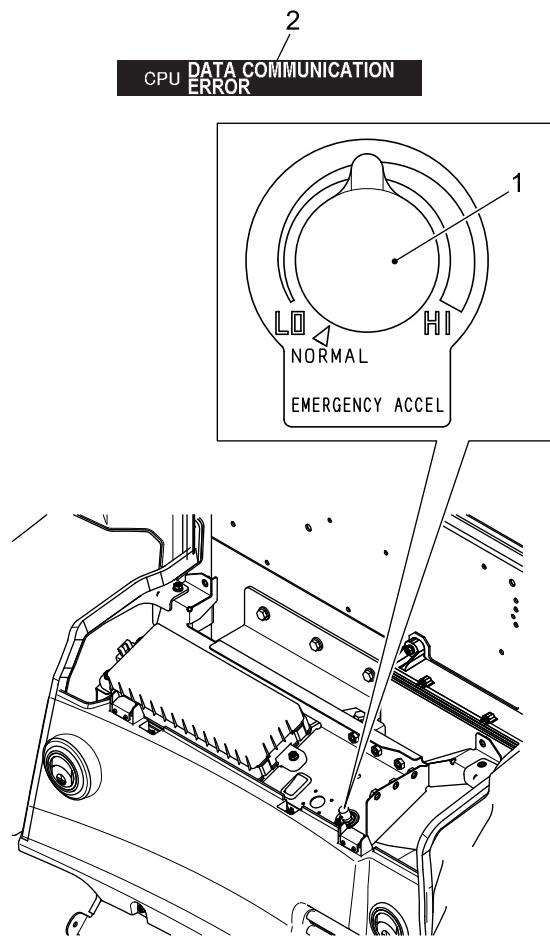

### OPERATION PROCEDURES

When operating the emergency accel, follow the procedures below.



#### HOW TO HANDLE EMERGENCY ACCEL

Be sure to follow the procedures for the emergency accel. Because the engine speed may rise suddenly when the engine starts, and it is extremely dangerous.

- 
1. Stop the engine, and set emergency accel (1) to "NORMAL".
  2. Start the engine.
  3. Turn emergency accel (1) to the HI side to adjust the engine speed.
  4. When stopping the engine, set emergency accel (1) to "NORMAL".

## 2.4.9 SWING PARKING BRAKE RELEASE SWITCH



### SWING PARKING BRAKE RELEASE SWITCH

Do not operate the swing parking brake release switch on slopes and soft grounds. The upper structure may turn unexpectedly and it is significantly dangerous.

This switch is used only when the swing parking brake cannot be released due to trouble. Set this switch to "RELEASE" to release the brake.

Generally, the switch should be on "NORMAL". When trouble is found in the swing parking brake systems, contact your KOBELCO authorized dealer promptly.

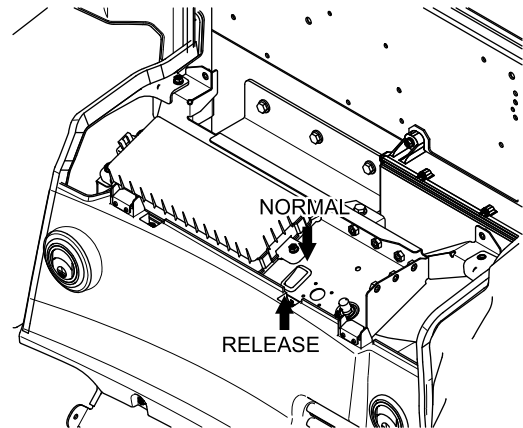

2

## 2.4.10 KPSS RELEASE SWITCH

Use this dial when the controller controlling this machine has failure. When operating this machine becomes impossible due to the controller failure, set this KPSS release switch (1) to "RELEASE" to operate the machine. However, the speed of the machine is limited. Under normal conditions, the switch should be on "KPSS (work mode)".

When controller warning (2) indicating failure of the controller is displayed on the monitor, immediately contact your KOBELCO authorized dealer.

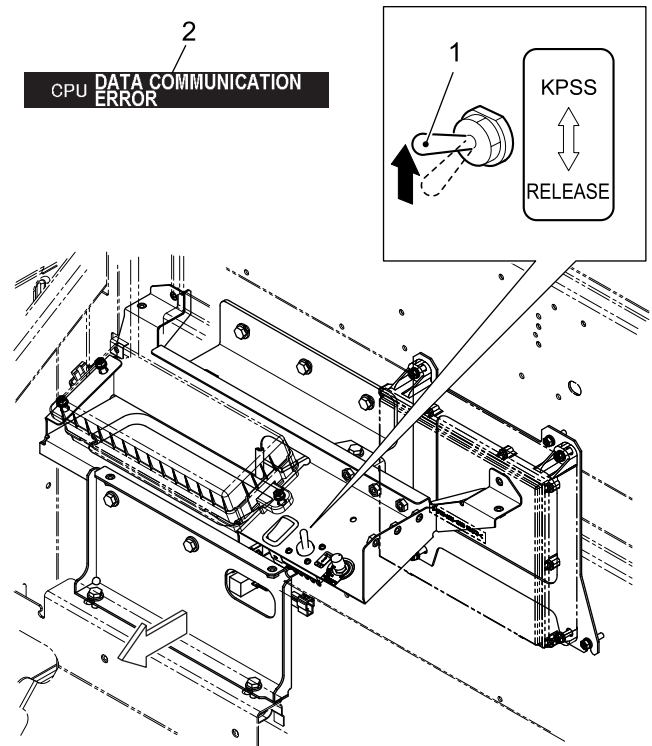

## 2.4.11 ENGINE STOP SWITCH

**Notice**

Do not use this switch to stop the engine under normal conditions.

When the engine does not stop due to trouble and damage of the machine even when turning the starter switch "OFF", lift up the switch near the lower left side of the seat to stop the engine. When not using this switch, always keep the switch down.

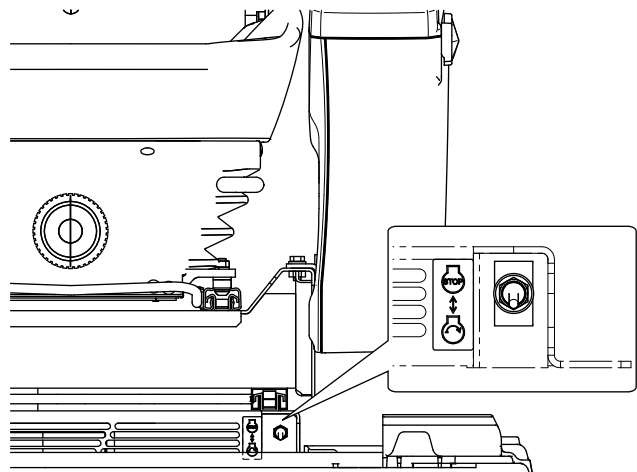

## 2.4.12 12 V POWER SUPPLY

Twelve volt power supply (1) is located at the lower side of the right control stand.

When using accessories such as a fan for general automobiles and other accessories that require the 12 V DC power supply, the 12 V power supply is required. Remove the cover from the 12 V power supply, and insert a 12 V male socket. After using the accessory, put the cover back on.

Maximum continuous output = 180 W

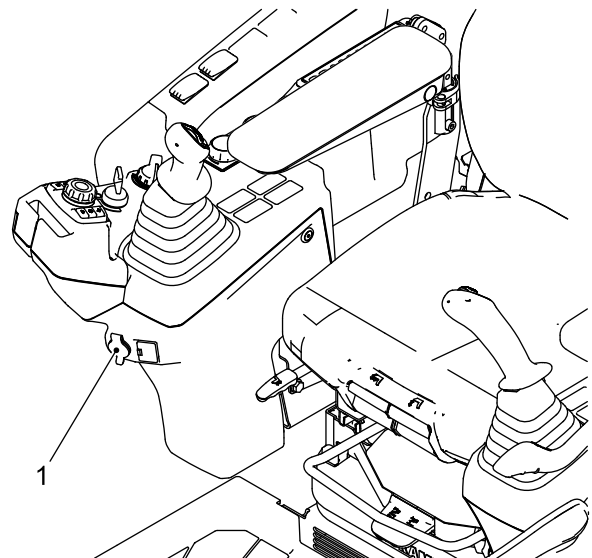

## 2.4.13 USB PORT/EXTERNAL INPUT TERMINAL (AUX)

### Notice

- This part does not guarantee connection with all types of USB terminals and AUX terminals. Also, when each terminal does not match the inlet of this machine, connection is not available.
- For use of external sound devices and USB memories, follow the manuals for them respectively.

Using the USB port/external input terminal (AUX), you can listen to music from a cell phone and external sound device.

The USB port and the external input terminal are located at the lower side of the right control stand inside the cab. When using them, open cap (1), and connect each cable (sold separately). When they are is not used, close cap (1).

### USB PORT

Use your USB device memory to listen to music files from the machine's speakers. For playable music files, and connection with USB memories, see "HANDLING OF RADIO" in Chapter 2.

### EXTERNAL INPUT TERMINAL (AUX)

Connect a digital audio player, etc. to listen to music from the machine's speakers. For connection cables, see "HANDLING OF RADIO" in Chapter 2.

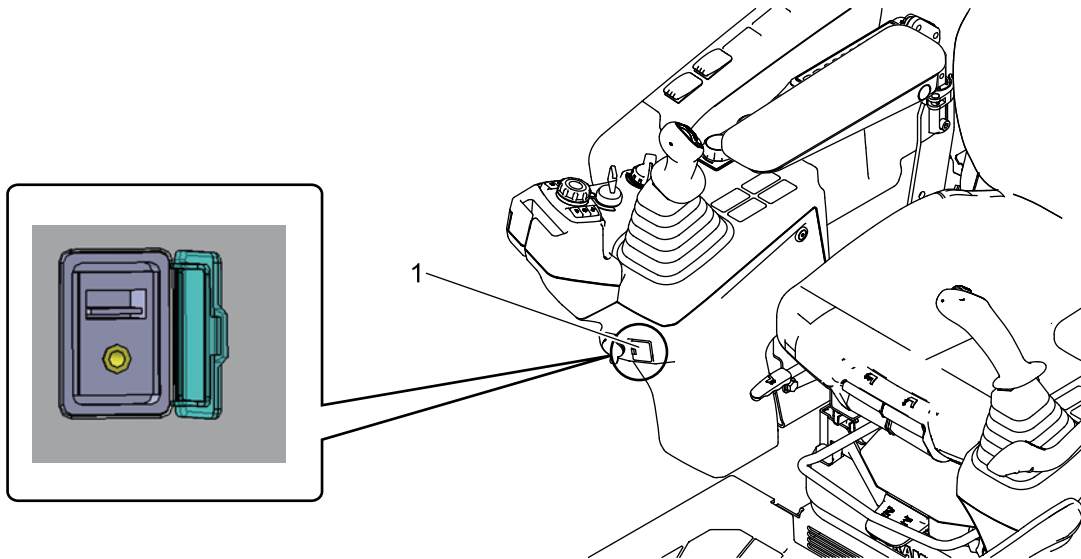

## 2.5 HANDLING OF LEVERS AND PEDALS

### 2.5.1 LOCATION OF LEVERS AND PEDALS

- (1) Control Lock Lever
- (2) Operator Control Levers
- (3) Travel Levers
- (4) Operator Control Lever for Dozer

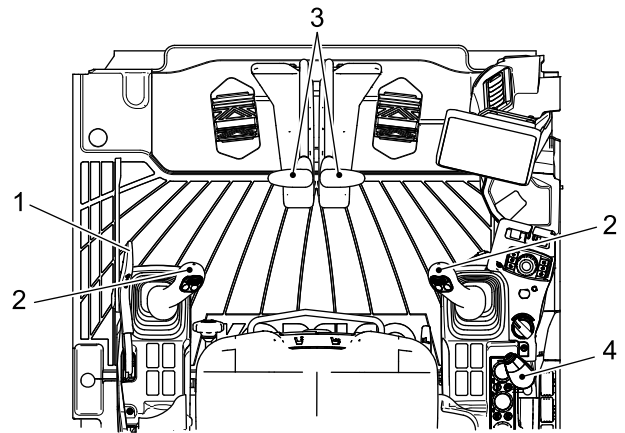

## 2.5.2 CONTROL LOCK LEVER

The control lock lever is provided to prevent any unexpected operation due to unexpected contact with the left/right control levers or travel levers.



### HANDLING OF CONTROL LOCK LEVER

- Do not stand up and move during operation, or unexpected contact with the control levers may cause a sudden movement of the machine. Raise the control lock lever securely to the "LOCKED" position before standing up or moving.
- Set the control lock lever to the "LOCKED" position securely, or it may not be locked. Make sure that the control lock lever is at the "LOCKED" position shown in the figure.
- When unlocking, do not touch other levers unintentionally. Touching other levers may cause danger due to unexpected machine movement.
- After completion of work or during transportation, be sure to set the control lock lever to the "LOCKED" position.
- Do not get on and off the machine holding the control lock lever.

### LOCKING HYDRAULIC SYSTEM

When the control lock lever is raised to "LOCKED" position (A), the operation control function is locked.

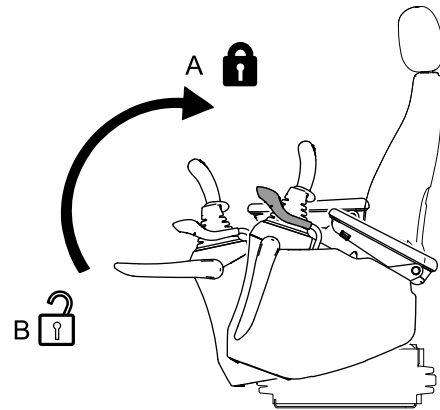

### UNLOCKING HYDRAULIC SYSTEM

When the lever is lowered to the "UNLOCKED" position (B), the hydraulic system is unlocked.

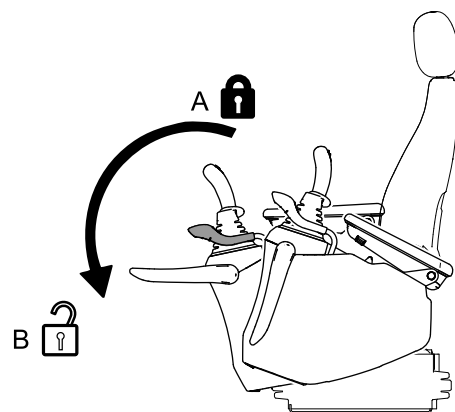

## 2.5.3 OPERATOR CONTROL LEVERS



### CONTROL OF LEVERS

- Before operation, be sure to pay attention to the safety of the surroundings and operate each lever slowly to fully make sure that the machine movement is in accordance with the control pattern indicated on the control pattern label in the cab.
- If you operate the machine while the control pattern label in the cab does not match the actual machine movement, it may cause severe personal injury.
- When the label does not match the actual machine movement, replace them with a proper one.
- When stopping swing operation, stop it earlier than your intended position by taking the swing distance after returning the swing lever to the neutral position into account.

The swing operation and the attachment/equipment are operated with the left and right control levers.

The left control lever is used for swing and arm operations.

The right control lever is used for boom and bucket operations.

Release the lever to return it to the neutral position and stop the attachment/equipment from moving. It is possible to perform various operations at the same time.

#### Left control lever

(1) Swing right

(2) Swing left

(3) Arm out

(4) Arm in

N (Neutral): Upper structure and arm are held in the position at that time

#### Right control lever

(5) Boom down

(6) Boom up

(7) Bucket in

(8) Bucket out

N (Neutral): Boom and bucket are held in the position at that time

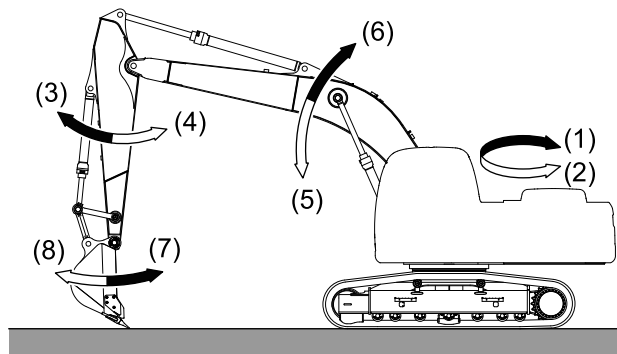
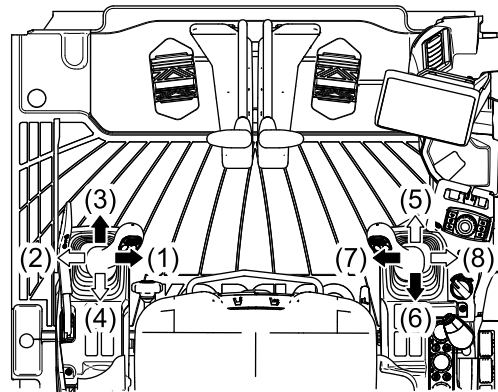



## 2.5.4 TRAVEL LEVER & PEDAL



### HANDLING OF THE TRAVEL LEVER & PEDAL

- During travel operation, pay attention to the control levers. There is a possibility of accident because the attachment is suddenly swung and moved by the unexpectedly touching and shifting the control lever.
- When operating the travel levers, check the crawler frame direction. When the travel motor is positioned on the front side, the traveling lever operation is reversed.
- If you put your foot on a pedal during work, there is a possibility of severe injury because the machine will start abruptly if the pedal is depressed unintentionally. Do not put your foot on a pedal, except for driving or turning with pedals.
- Pay attention when driving and operating with pedals.

### FRONT/REAR AND LEFT/RIGHT OF MACHINE

In this manual, front/rear and left/right are determined by looking the forward direction from the operator's seat with the travel motors at the rear side.

The manual levers and travel pedals are used for the travel operation of this machine.

(a) Travel forward: Push the travel levers to the front

(Depress the front of travel pedals)

(b) Travel backward: Pull the travel levers toward yourself (Depress the back of travel pedals)

(N) Neutral: The machine stops traveling.

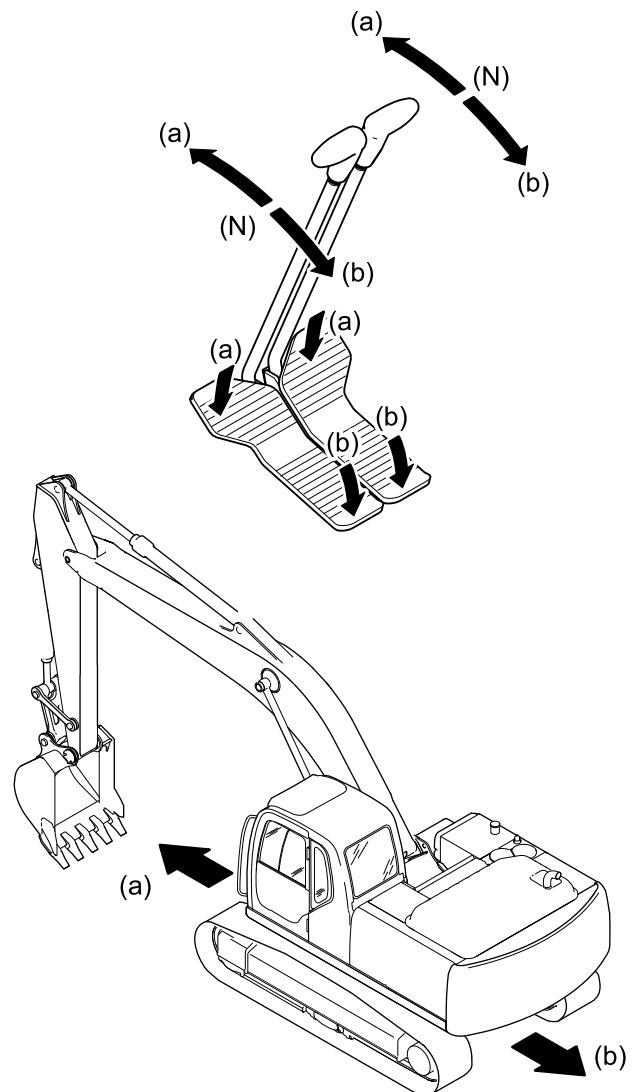

## 2.5.5 DOZER OPERATION LEVER

The dozer is operated with dozer control lever (1) located on the right of the right control lever as shown in the right figure. If dozer control lever (1) is released, the lever returns to the neutral position and the dozer is held at the position at that time.

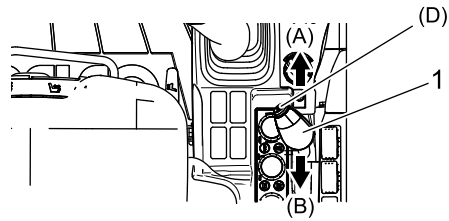

LEVER CONTROL	DOZER MOTION
PUSH LEVER FORWARD (A)	DOZER DOWN
PULL LEVER BACKWARD (B)	DOZER UP
NEUTRAL (C)	HOLD
TRAVEL SPEED SELECT SWITCH (D)	Changes travel speed to LOW (1st) or HIGH (2nd)

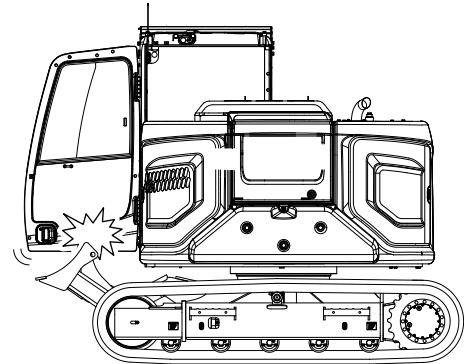
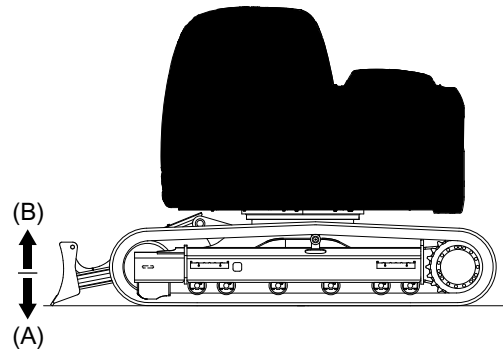

### **CAUTION**

In case of dozer machines, when setting the upper structure laterally with the dozer raised uppermost, it can cause the open door to interfere with the dozer depending on the specifications.

## 2.6 HANDLING OF FUSE & RELAY BOX

### 2.6.1 ABOUT FUSE & RELAY BOX

The fuses protect the wiring and electrical components from damage of burning out due to excess current. If the electrical system does not work properly, check to replace any blown fuses with new ones. If there is a corroded fuse generating white powder on it, or if some looseness exists between a fuse and its fuse holder, replace it as well.

### 2.6.2 REPLACING FUSES

#### **CAUTION**

Make sure the starter switch is in the "OFF" position when replacing fuses.

#### **Notice**

- The spare fuses are stored in the fuse & relay box.
- A fuse must be replaced with a one of the same type and capacity of that of the blown fuses. The electrical system may be damaged if a different one is used.  
If fuse replacement is frequently required, it may be due to a failure in the electrical system. Please contact KOBELCO authorized dealer/distributor.

1. To remove the fuse box cover at the rear side of the operator's seat, push lock part (2) of cover (1) inward and release the lock and then lift the cover.
2. When replacing the fuse, use a fuse extractor to remove it from the fuse box.
3. After replacing the fuse, install the cover securely.

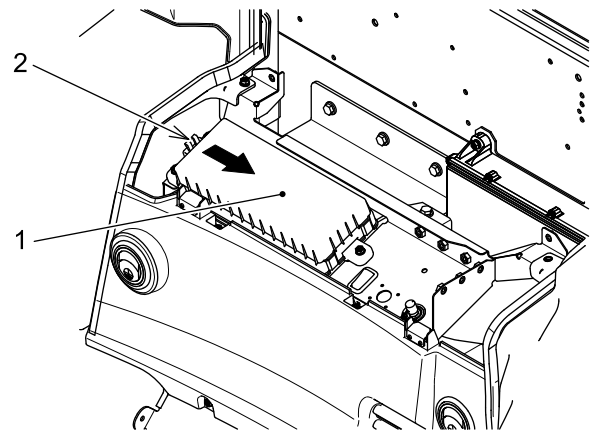

## [2. MACHINE FAMILIARIZATION]

### 2.6.3 FUSE CAPACITY AND CIRCUIT NAME

The following shows each fuse capacity and circuit name.

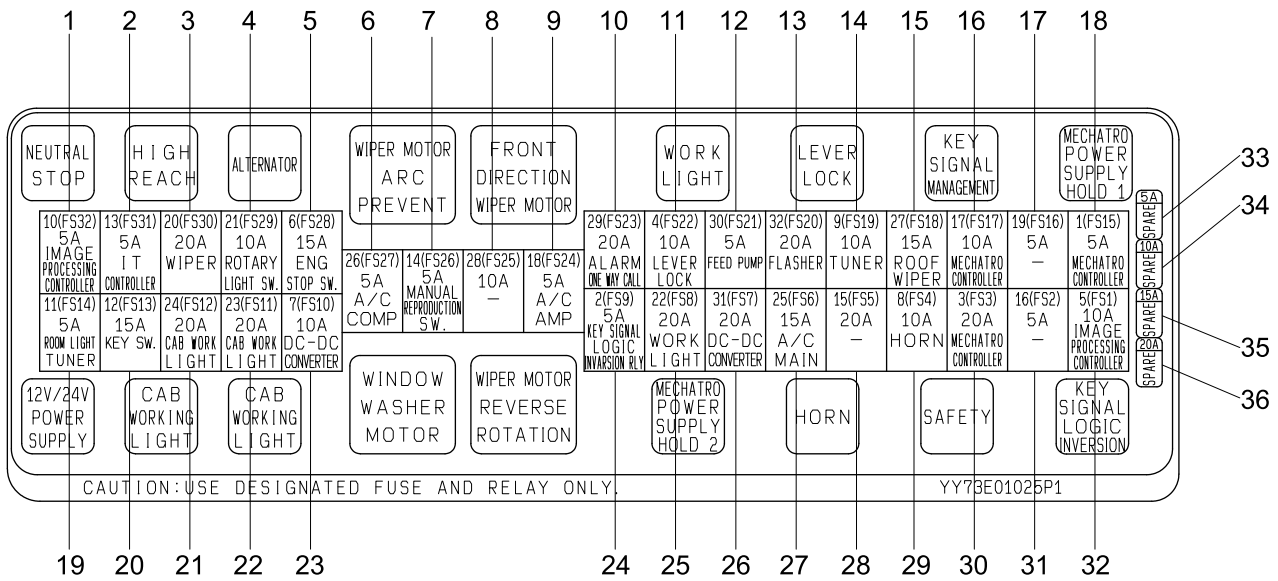

Item	Capacity	Circuit Name	Item	Capacity	Circuit Name
1	5A	Image processing controller	19	5A	Room lamp, tuner
2	5A	IT controller	20	15A	Key switch
3	20A	Wiper	21	20A	Cab working light
4	10A	Rotary light switch	22	20A	Cab working light
5	15A	Engine stop switch	23	10A	DC-DC converter
6	5A	Air conditioner	24	5A	Key signal logic inversion relay
7	5A	Manual regeneration switch	25	20A	Working light
8	10A	-	26	20A	DC-DC converter
9	5A	Air con. Amp.	27	15A	Air conditioner
10	20A	Travel alarm	28	20A	-
11	10A	Lever lock	29	10A	Horn
12	5A	Feed pump	30	20A	Mechatro controller
13	20A	Flasher	31	5A	-
14	10A	Tuner	32	10A	Image processing controller
15	15A	Skylight wiper	33	5A	Spare fuse
16	10A	Mechatro controller	34	10A	Spare fuse
17	5A	-	35	15A	Spare fuse
18	5A	Mechatro controller	36	20A	Spare fuse

## 2.7 HANDLING OF FUSIBLE LINK (FOR STARTER)

### Notice

The fusible link is a fuse wiring of big size provided in a large capacity circuit. As with normal fuses, it protects electrical components and wiring from burn out due to excess current.

In case the starter does not work when the starter switch is turned "ON", disconnection of the fusible link is suspected. Check and replace it as needed.

### 2.7.1 FUSIBLE LINK INSPECTION/REPLACEMENT

#### CAUTION

Remove the negative (-) terminal of the battery to shut down the flow of electricity to avoid electric shock and short circuit leading to damages of the component.

When the battery power-off switch is provided, set it to "OFF".

1. Use the starter key to open the side door at the left side of the machine and hold it with the stay.
2. Remove fusible link (1), and perform inspection or replace it with a new one.
3. Remove the supporting stay, and close the side door.

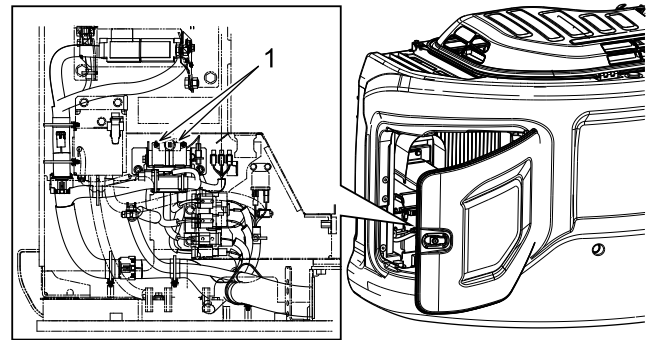

## 2.8 CONTROLLER

### **CAUTION**

- Be careful not to splash water, mud and drinks on the controller. It may cause failure.
- When the controller warning is displayed on the monitor, contact your KOBELCO authorized dealer. See "WARNING DISPLAY SCREEN" in Chapter 2 for warnings.

The controller controlling the machine and the engine is equipped in this machine.

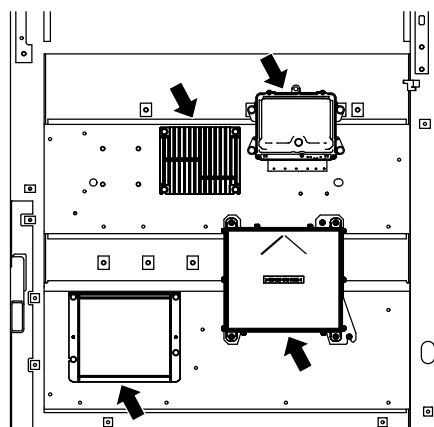
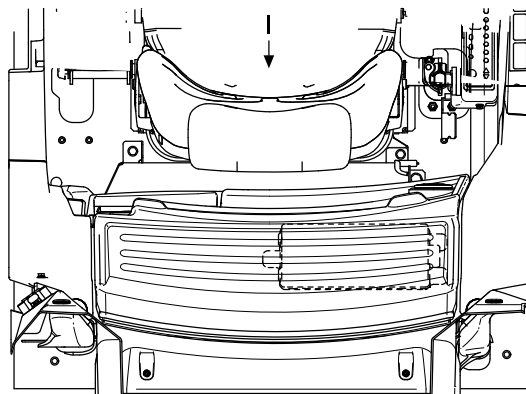

VIEW I

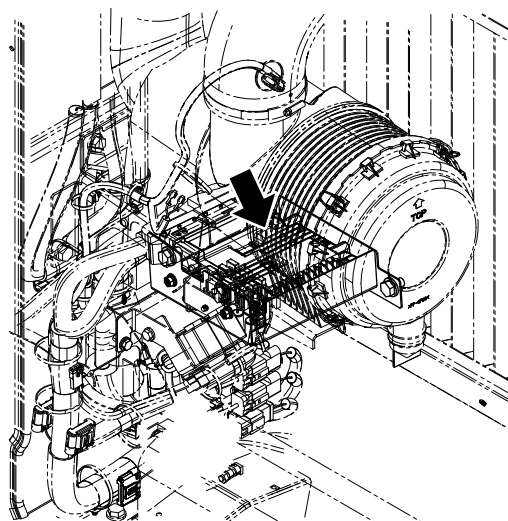

## 2.9 HANDLING OF RADIO

### **CAUTION**

Do not operate the radio during operation.

Lower the attachment to the ground, pull up the control lock lever to the "LOCKED" position, and then operate the radio.

### 2.9.1 NAME OF EACH PART

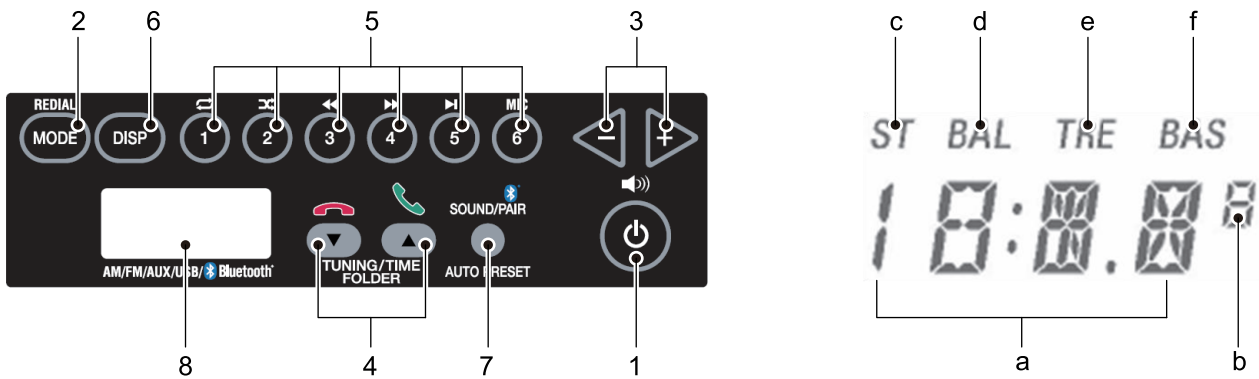

Item	Name	Function
1	[PWR] Key	Turns the power of the radio ON/OFF. In each explanation, "ON" is described as "OnAir".
2	[MODE] Key	Switches the band (AM/FM1/FM2) and the radio (AM/FM1/FM2), AUX, USB, and BT(Bluetooth). If pressed and hold, redial is performed.
3	[VOL+] [VOL-] Key	Adjusts the volume.
4	[UP] [DOWN] Key	Switches the frequency, adjusts steps at the sound adjustment, and adjusts the clock. Also, when a call is received, press [UP] to start conversation, and press [DOWN] to finish the conversation.
5	[PRESET] Key (1 to 6)	Recalls and registers preset frequency. Also, in use of BT(Bluetooth)/USB, performs repeat, random, track forward/backward, and pause.
6	[DISP] Key	Switches the display (frequency/clock).
7	[SOUND PAIR] Key	Adjusts the sound (balance/bass/treble) and performs pairing.
8	LCD Display	Displays the frequency and the clock.
a	Segment (Large)	Displays the letter/value information such as the name of the source, the frequency, and the clock.
b	Segment (Small)	Displays the frequency at the step of FM50kHz.
c	ST Pict	Turns on if stereo sound is received with FM1/FM2 selected.
d	BAL Pict	Turns on at balance adjustment in sound adjustment.
e	TRE Pict	Turns on at treble adjustment in sound adjustment.
f	BAS Pict	Turns on at bass adjustment in sound adjustment.



## 2.9.2 ON-AIR (NORMAL CONDITION)

With the radio component in the OFF condition, press [PWR] key to turn the radio ON (on-air condition). Then the frequency selected now starts to be received.



OFF (clock display)  
 {Colon blinks (ON: 700 ms, OFF: 300 ms)}

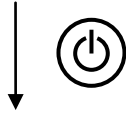

After 1 sec.



ON (on-air): Band name display

In this condition, press [DISP] key to switch the frequency display and the time display.

If the source is AUX, the AUX display and the clock display are switched.

(When the clock display is switched to the frequency display, the band name is displayed for 1 sec. and then the display is changed to the frequency display.)



Frequency display

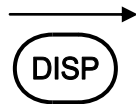

Clock display  
 {Colon blinks (ON: 700 ms, OFF: 300 ms)}

After 1 sec.



ON (on-air): Band name display



### 2.9.3 SWITCHING SOURCE

With the radio component in the on-air (normal) condition, press [MODE] key to switch the source.

After the source is switched, each source works as follows.

- AM/FM: Receives the frequency received at the previous time by the selected band.
- AUX: Outputs the sound of the device connected to the AUX terminal from the speakers of this radio component.
- USB: Plays the mp3 file inside the USB memory connected to the USB terminal and outputs the sound from the speakers of the radio component.
- BT: Outputs the sound of the device connected though Bluetooth (A2DP) from the speakers of this radio component.

The sources are switched in the order of AM→FM1→FM2→AUX→USB→BT→AM.

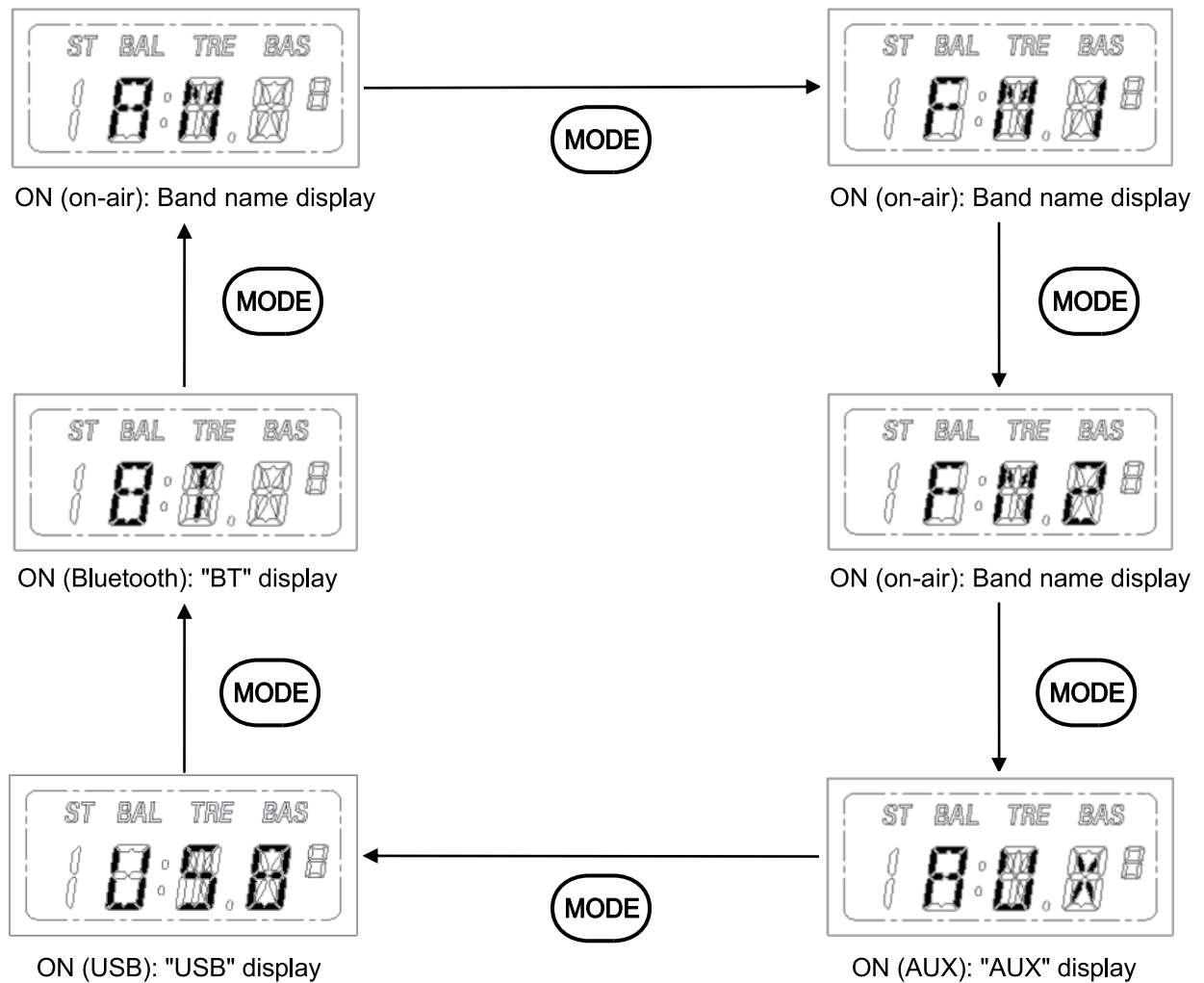

## [2. MACHINE FAMILIARIZATION]

### 2.9.4 FM/AM

#### FREQUENCY ADJUSTMENT (1 STEP UP OR 1 STEP DOWN)

With the radio component in the on-air (normal) condition, press [UP] key to increase the frequency by 1 step. Also, press [DOWN] key to decrease the frequency by 1 step.

(In case that selected band is FM1/FM2)



Frequency display  
(When stereo sound is received, "ST" pict turns on)

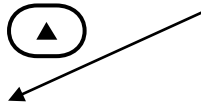

Frequency display  
(When stereo sound is not received, "ST" pict turns off)



Frequency display  
(When stereo sound is not received, "ST" pict turns off)

(In case that selected band is AM)



Frequency display  
(When AM is selected, "ST" pict always turns on)

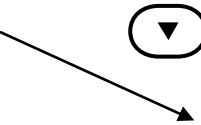
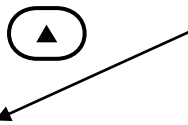

Frequency display  
(When AM is selected, "ST" pict always turns on)



Frequency display  
(When AM is selected, "ST" pict always turns on)

FREQUENCY ADJUSTMENT (AUTOMATIC SEEKING)

With the radio component in the on-air (normal) condition, press and hold [UP] key to increase the frequency by 1 step consecutively.

Also, press and hold [DOWN] key to decrease the frequency by 1 step consecutively.

When the well-received frequency is detected, the auto seeking operation stops and the radio becomes the on-air condition.

(In case that selected band is FM1)

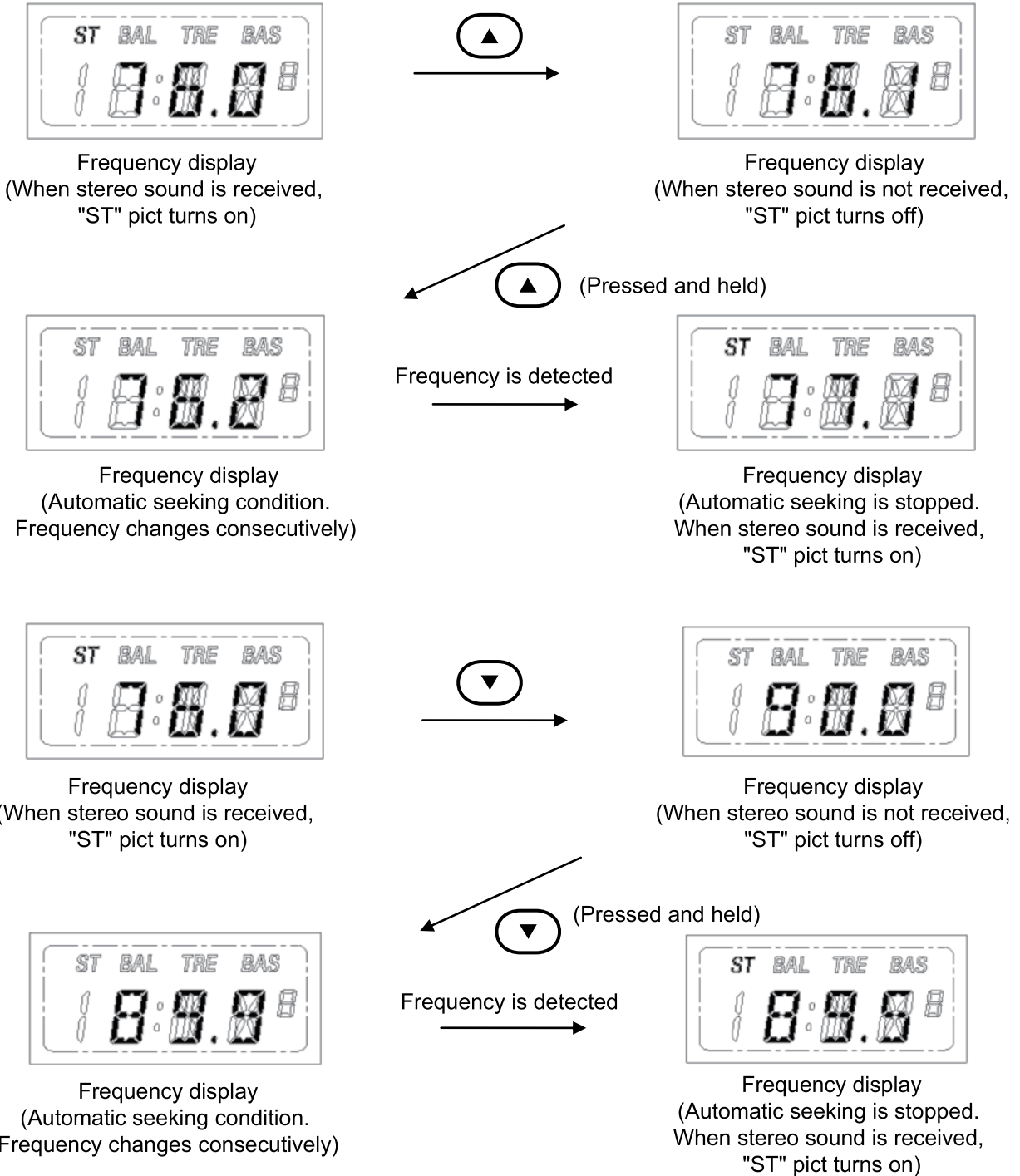

## [2. MACHINE FAMILIARIZATION]

### FREQUENCY ADJUSTMENT (AUTOMATIC PRESETTING)

With the radio component in the on-air (normal) condition, press and hold [SOUND/PAIR] key to start the automatic presetting function of which the well-received frequency is detected and stored in the preset memories of 1 to 6 automatically.

In the presetting function, the frequencies are set to the preset memories of 1 to 6 in the order of strongly received radio waves.

During operation of the automatic presetting function, the following automatic presetting display (the display position of "A" is renewed at every certain period) is displayed and when the operation is finished (with 2 beep sounds), this display is turned off and the frequency stored in preset 1 is on-aired.

(In case that selected band is FM1)

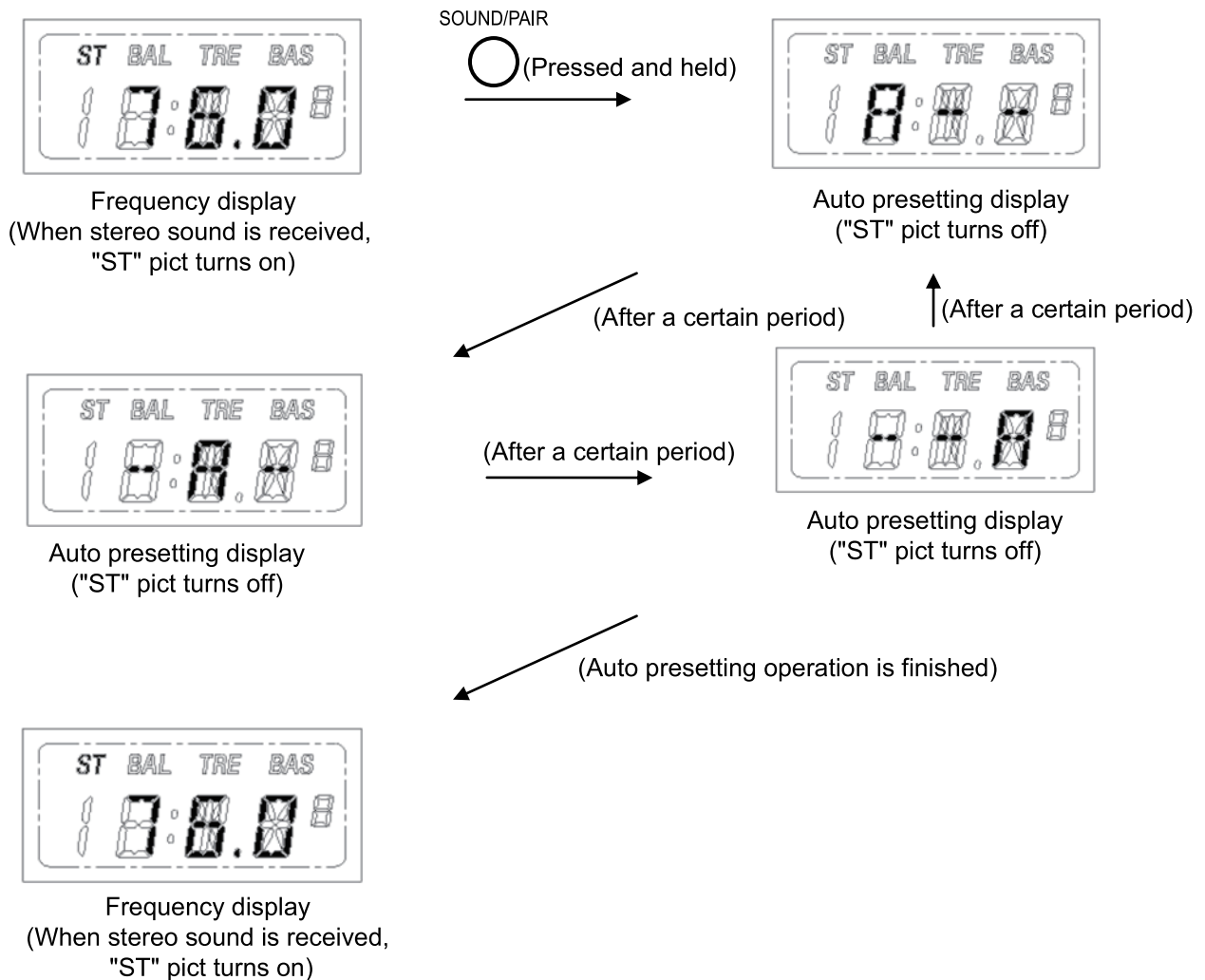

RECALLING PRESET FREQUENCY

With the radio component in the on-air (normal) condition, press any of [PRESET] key (1 to 6) to recall the frequency stored in that preset number and on-air it.

{In case that selected band is FM1 (76.0 MHz has already been stored in preset No.1)}

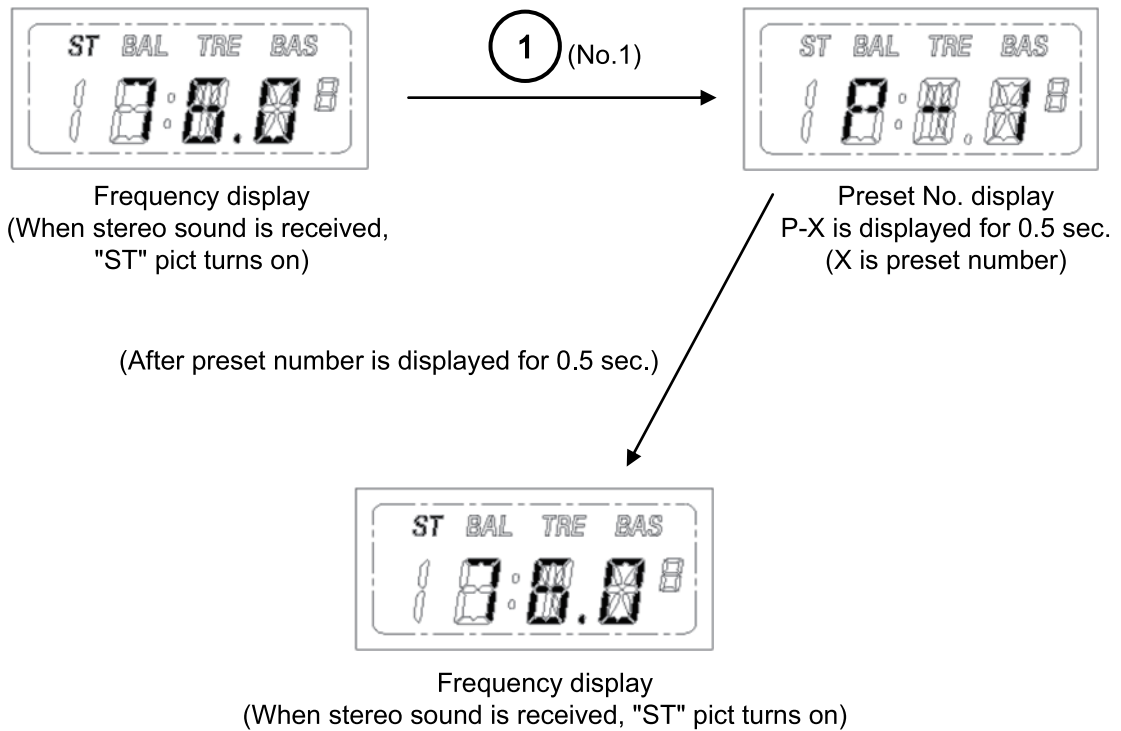

## [2. MACHINE FAMILIARIZATION]

### PRESET MEMORY

If any one of [PRESET] keys (1 to 6) is pressed and held under the on-air (normal) condition, the frequency received now is stored to that preset number.

At this time, the preset number display blinks 3 times and then the frequency display turns on.

(In case that selected band is FM1)

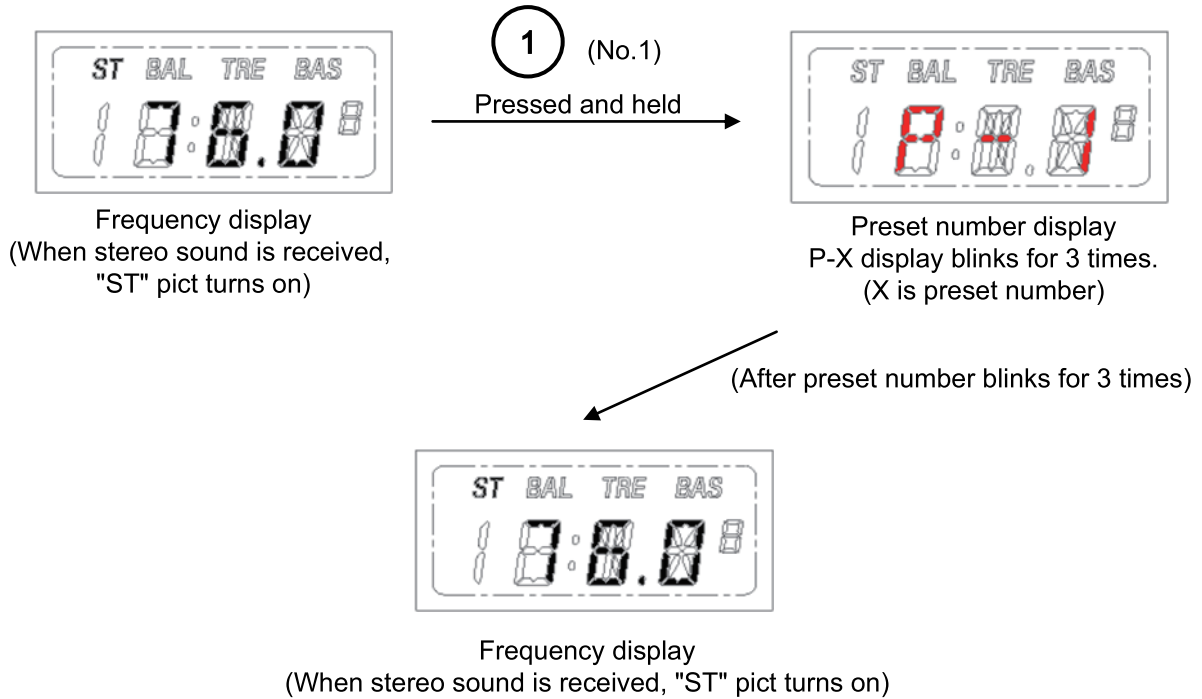

## 2.9.5 BLUETOOTH AUDIO FUNCTION, AND USB PORT/EXTERNAL INPUT TERMINAL

Using the Bluetooth Audio function, and USB port/external input terminal (AUX) of this machine, you can listen to music from a cell phone and external sound device.

### Notice

#### Bluetooth Audio

- The Bluetooth Audio function of this machine does not guarantee wireless connection with all types of devices supporting Bluetooth. Devices like cell phones, etc. to be connected need to meet the Bluetooth standard determined by SIG and to be certified. Even if devices to be connected meet the Bluetooth standard, some devices may have connection problems, display/operation differences, or skipping sound.
- For the use of Bluetooth, follow the instruction manual of each device.
- Bluetooth in this machine may adversely affect some medical electric devices such as a cardiac pacemaker. When using Bluetooth Audio near medical electric devices, be very careful and ask applicable medical electric device manufacturers beforehand for use of Bluetooth.

#### USB PORT/EXTERNAL INPUT TERMINAL (AUX)

- USB port and external input terminal in this machine do not guarantee connection with all types of USB terminal and AUX terminal. Also, when each terminal does not match the inlet of this machine, a connection is not available.
- For use of external sound devices and USB memories, follow the manuals for them respectively.

#### File System Condition

Item		Contents	
File system		FAT16/32, no distinction between upper and lower case letters	
Number of files		Root folder	Sub folder
	FAT16	512	65534
	FAT32	65535	65534
Number of layers		16 layers, full pass including file name is within 260 letters	
Sort order		Plays in UNICODE order	
Supported file format		MP3 / WMA / AAC	

## [2. MACHINE FAMILIARIZATION]

### Supported format

Item		MP3	WMA	AAC
Supported format		MPEG 1/2, 2.5 Layer1, 2 and 3	WMA Ver.9 Standard (DRM is not supported)	MPEG4 AAC-LC (DRM is not supported)
Sampling rate	8k	Yes	Yes	
	16k	Yes	Yes	
	32k	Yes	Yes	
	11.025k	Yes	Yes	
	22.05k	Yes	Yes	
	44.1k	Yes	Yes	Yes
	12k	Yes		
	24k	Yes		
	48k	Yes	Yes	
Bit rate		Compatible with 8 to 320 kbps VBR	Compatible with 5 to 384 kbps VBR	Compatible with 64 to 320 kbps VBR
TAG information		Compatible with ID3TAG (V1.0/V1.1/V2.2/V2.3/V2.4)	Compatible with WMATAG	Compatible with AAC TAG
Extension		mp3	asf, wma	m4a, 3gp, mp4

- When the file data is constructed with a format other than the supported formats, or when the data header part is broken, the track is skipped to the next track.
- The supported files of AAC are that encoded with iTunes (version confirmed for support: 4.\*, 5.\*, 6.\*, 7.0-7.5). The AAC files encoded with other software may cause failures such as skipping to the next track during playing.

### Basic specification of Bluetooth

Item	Contents
Bluetooth version	3.0
Field intensity	Class 2
Maximum number of devices for pairing registration	16 units
Supported profile	A2DP / AVRCP / HFP / HSP / SPP

### RESUMING

With a USB file being played, if source change, SRC OFF, or ACC OFF is performed and then the USB is selected again, the part played before starts playing.

If the same USB memory is pulled out and inserted, the part played before starts playing.

If the USB memory is pulled out during playing, sometimes resuming becomes impossible.

If a different USB memory is inserted between the insertions of the same memory, resuming becomes impossible.



USB CHARGE

- A USB device connected to the USB (mobile phone or audio device) can be charged.
- In the USB charge, normal mode and charge dedicated mode are available, and at the charge dedicated mode, USB communication becomes impossible.  
(When the USB communication is impossible, playing audio files is impossible.)

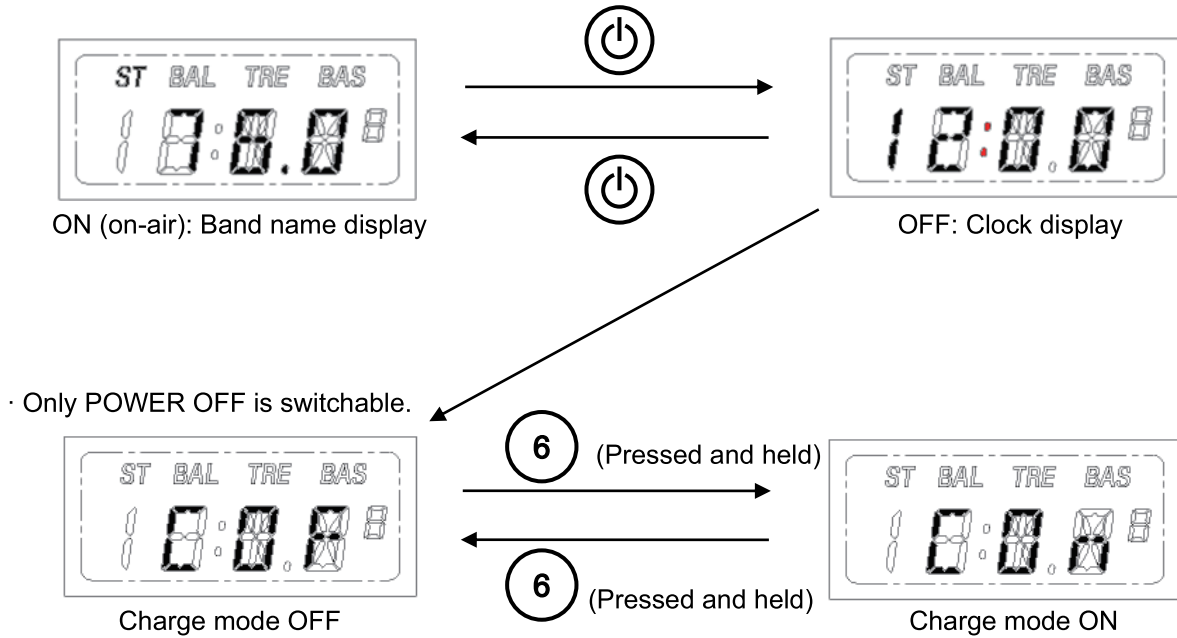

\* In the charge mode, the setting is obtained after POWER ON.

## 2.9.6 PAIRING (REGISTRATION OF DEVICES)

Bluetooth devices need prior registration of devices to be connected by each other. This registration is called "pairing".

The pairing is required between this radio component and a mobile phone or other Bluetooth device.

With the OnAir (normal) condition, push the [MODE] key and switch the band to Bluetooth condition.

With the band selecting Bluetooth, press and hold [SOUND/PAIR] to display "WA" and start the preparation of the pairing.

After the preparation of this radio component is finished, "PA" is displayed, and this radio component enters the pairing waiting condition.

If a device is searched from the Bluetooth device to be connected to this radio component, the screen of that Bluetooth device displays "BT-\*\*\*\*" (\* is 4 digits of English letters and numbers). The pairing operation shall be performed from the Bluetooth device to be connected.

If the pairing is performed normally, "P0" is displayed and the pairing is finished normally.

When the pairing is not completed within the limited time (180 sec.) or error occurs, "PX" is displayed and the radio component returns to the Bluetooth ON condition.

During the pairing operation, by pressing [PWR] key, the pairing is canceled.

\* Some mobile phones need entering of a pass key. Enter "0000" as a pass key.

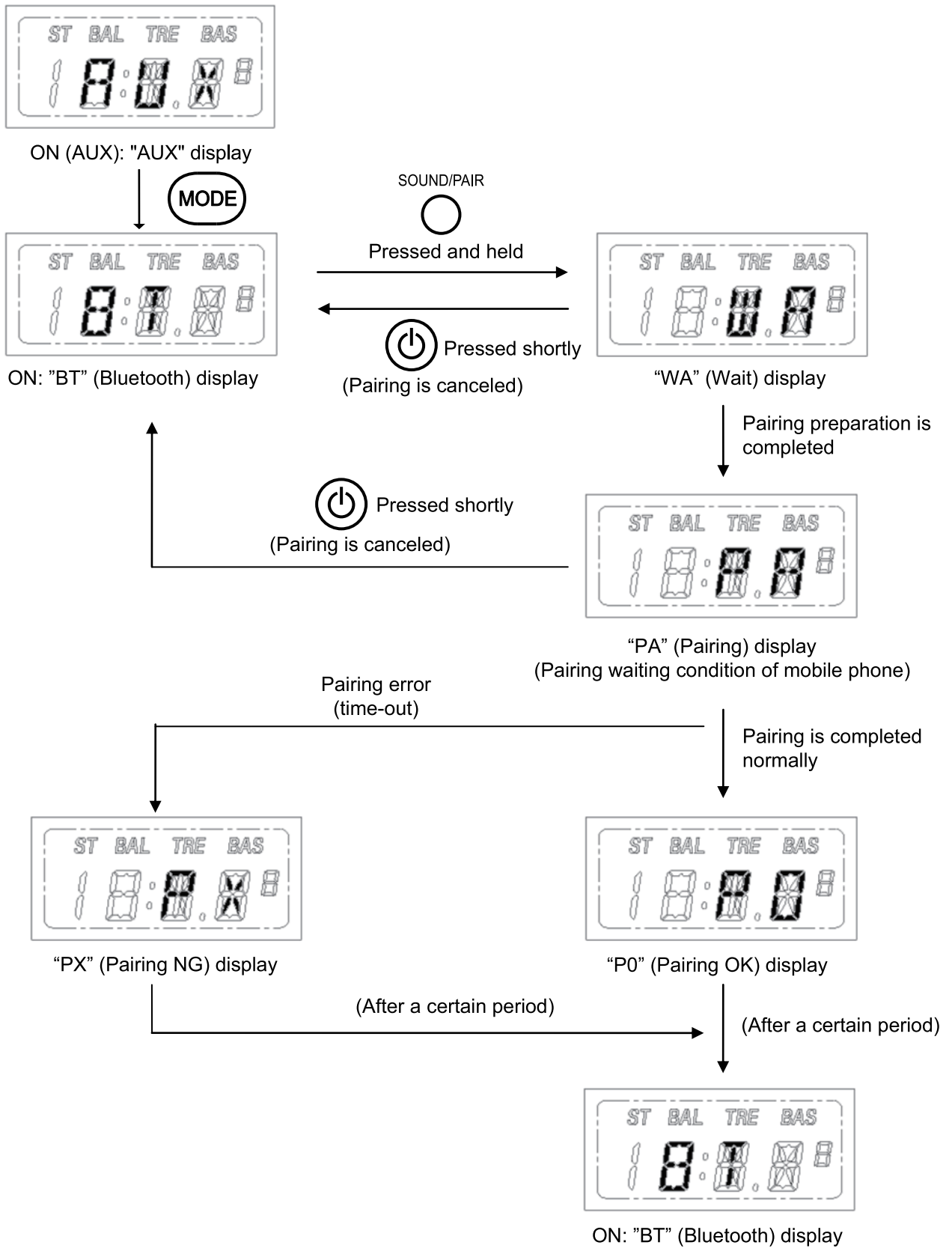

## 2.9.7 TELEPHONE FUNCTION

Before using this function, perform pairing (registration of a device).

### CONVERSATION

If the mobile phone connected through Bluetooth receives a phone call, regardless of the band selected at that time, "CL" is displayed and blinked and the ringtone is output from the speakers.

Even when this radio component is OFF, it automatically turns ON when receiving a phone call, and then displays and blinks "CL", and outputs the ringtone.

With the radio component receiving a phone call, press [UP] key to answer the phone call.

If the telephone number for which incoming call rejection has been performed is received, the radio component does not enter the communication status but changes to the band selected before receiving the phone call.

During the telephone conversation, by pressing [DOWN] key, the conversation is finished and the radio component changes to the status before receiving the phone call.

Moreover, by pressing [PRESET 6] key, the microphone can be turned OFF/ON.

When the microphone is turned OFF, input of the speaker's voice is stopped.

The previous turning OFF of the microphone is not stored. It is canceled by every time.

(In case that selected band is FM1)

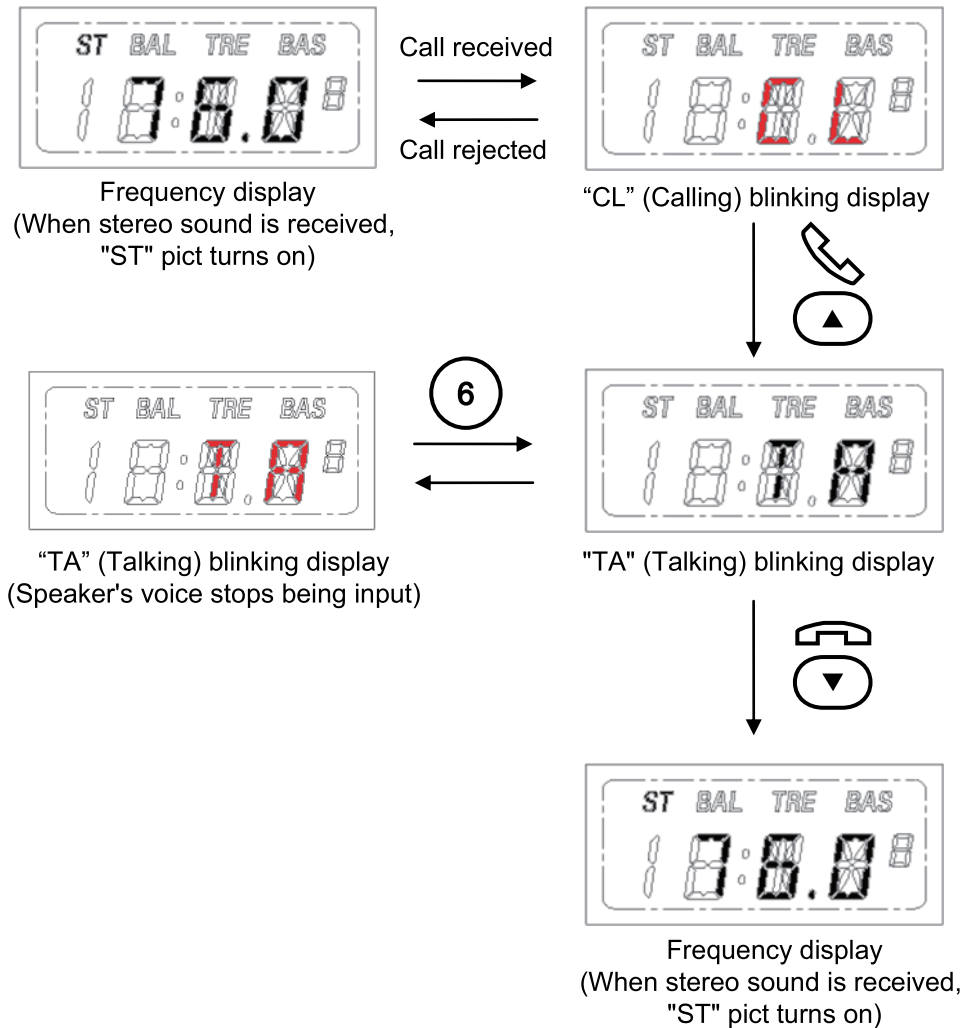

**REDIALING**

Regardless of the band selected now, by pressing and holding [MODE] key, "RE" is displayed for 3 sec. and after redialing is started, "DL" is displayed and blinked, and the ringtone is output from the speakers.

Even when this radio component is OFF, it automatically turns ON when performing redialing and enters the redialing process.

While making a phone call, if it is canceled, the radio component returns to the status before making the phone call.

The redialing function redials the telephone number received last time, after ACC ON.

If a phone call is received for a short time, some mobile phones cannot be applied to redialing.

(In case that selected band is FM1)

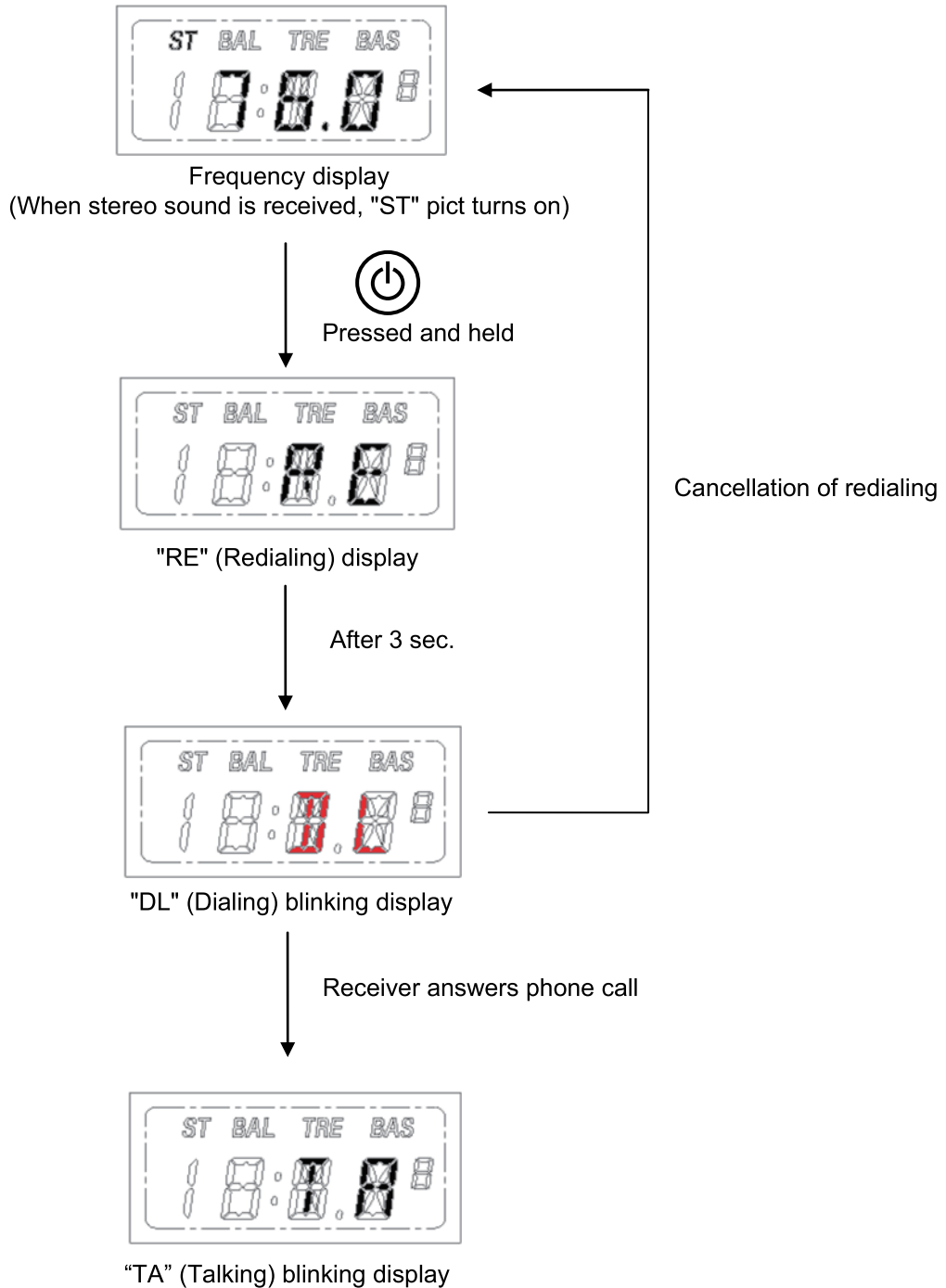

## 2.9.8 FILE PLAYING FUNCTION

Before using this function, pairing (registration of a device) shall be done.

### TRACK FORWARD/BACKWARD (USB/BT-AUDIO)

While a USB memory or BT-Audio is being played, press [PRESET 3] or [PRESET 4] to change the track forward/backward.

If moving track backward is operated after less than 1 sec. from the start of playing the track, the track moves to the previous track, however, in case of 1 sec. or more from the start, the playing part moves to the beginning of the same track.

(However, the playing time is not displayed.)

(In case of USB)

- In case of less than 1 sec.

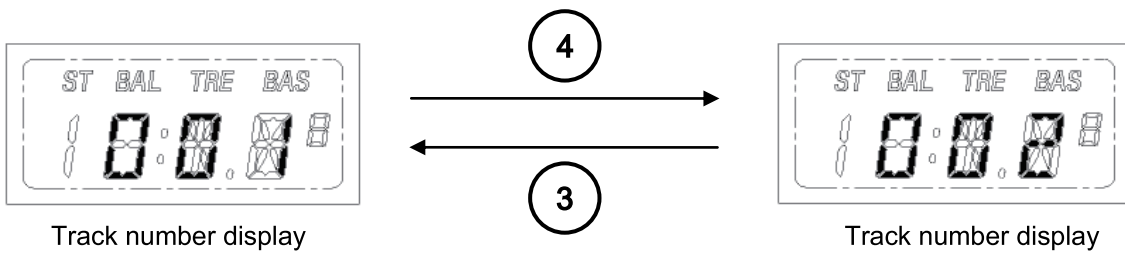

- In case of 1 sec. or more

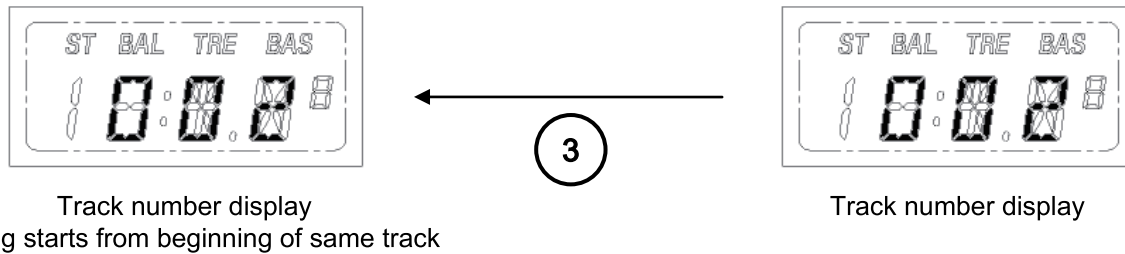

File number of 1000 or after is displayed as “---“



(In case of BT-Audio)

Due to the Bluetooth device limitation, the track number cannot be displayed.

FOLDER FORWARD/BACKWARD (USB)

A folder in the USB memory can be changed to another one to play MP3 files.

The numbers are also allocated to folders not including tracks capable of playing, so that during changing the folder forward/backward, sometimes the number is skipped.

Moreover, the root is F00.

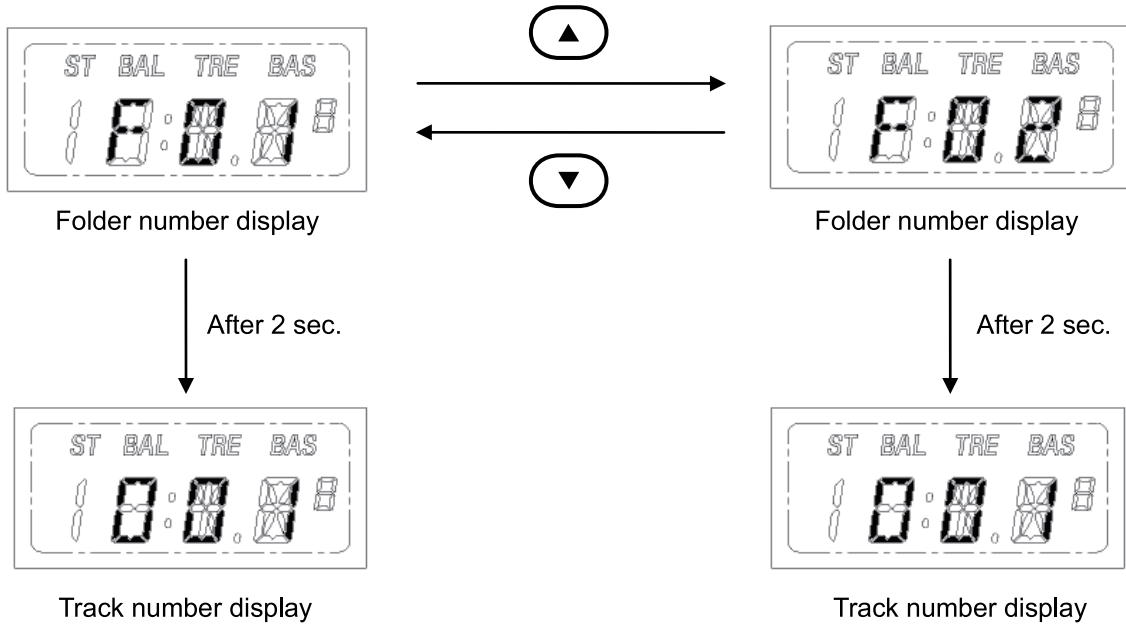

Folder number of 100 or after is displayed as “---”



(In case of iPhone/iPod)

An album can be changed forward/backward.

However, depending on the type of the iPhone/iPod connected, the track change may occur.

(Depending on the type of the iPhone/iPod)

## [2. MACHINE FAMILIARIZATION]

---

### PAUSE (USB AND BT-AUDIO)

While the USB memory or BT-Audio is being played, press [PRESET 5] to pause the track.

By pressing [PRESET 5] again, the track starts playing.

(In case of USB)

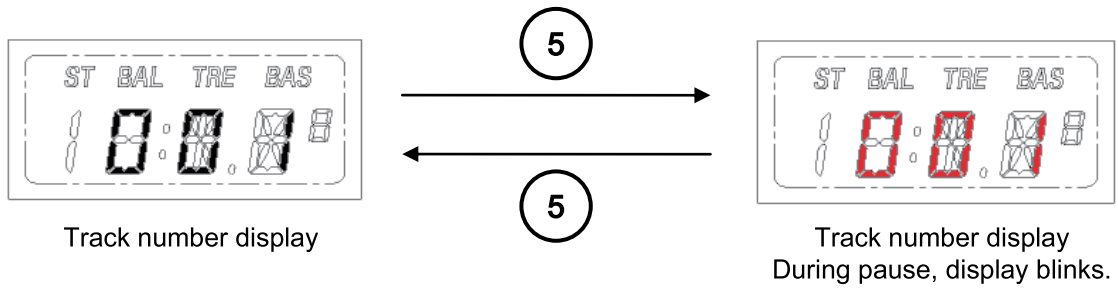

(In case of BT-Audio)

Due to the Bluetooth device limitation, during pause, the display does not blink.



REPEAT (USB)

While the USB memory is being played, press [PRESET 1] to display the present setting.  
Then, by pressing [PRESET 1], the setting is changed.

As for the setting of repeat and random, the last setting is effective.

(In case of USB memory)

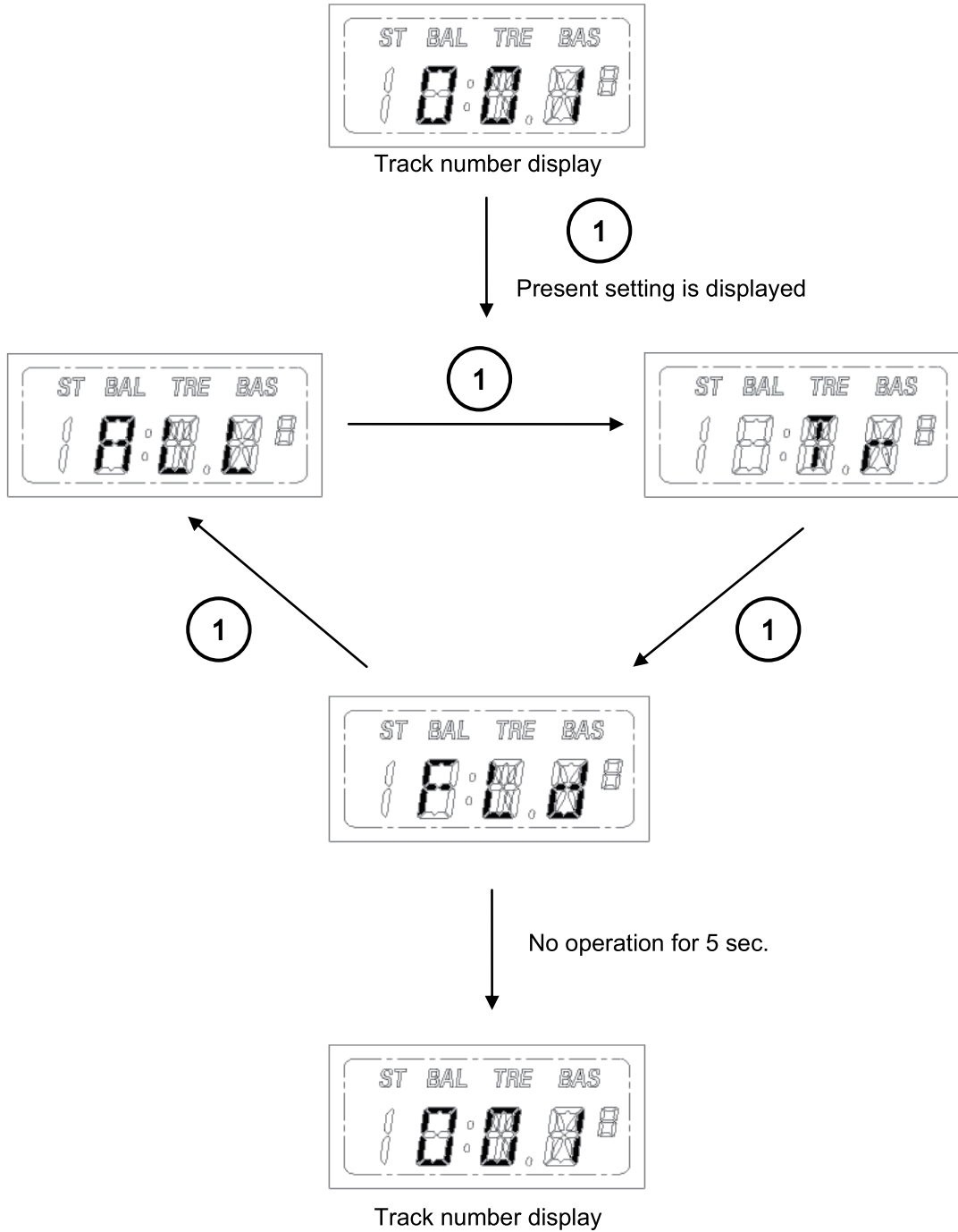

## [2. MACHINE FAMILIARIZATION]

(In case of iPhone/iPod)

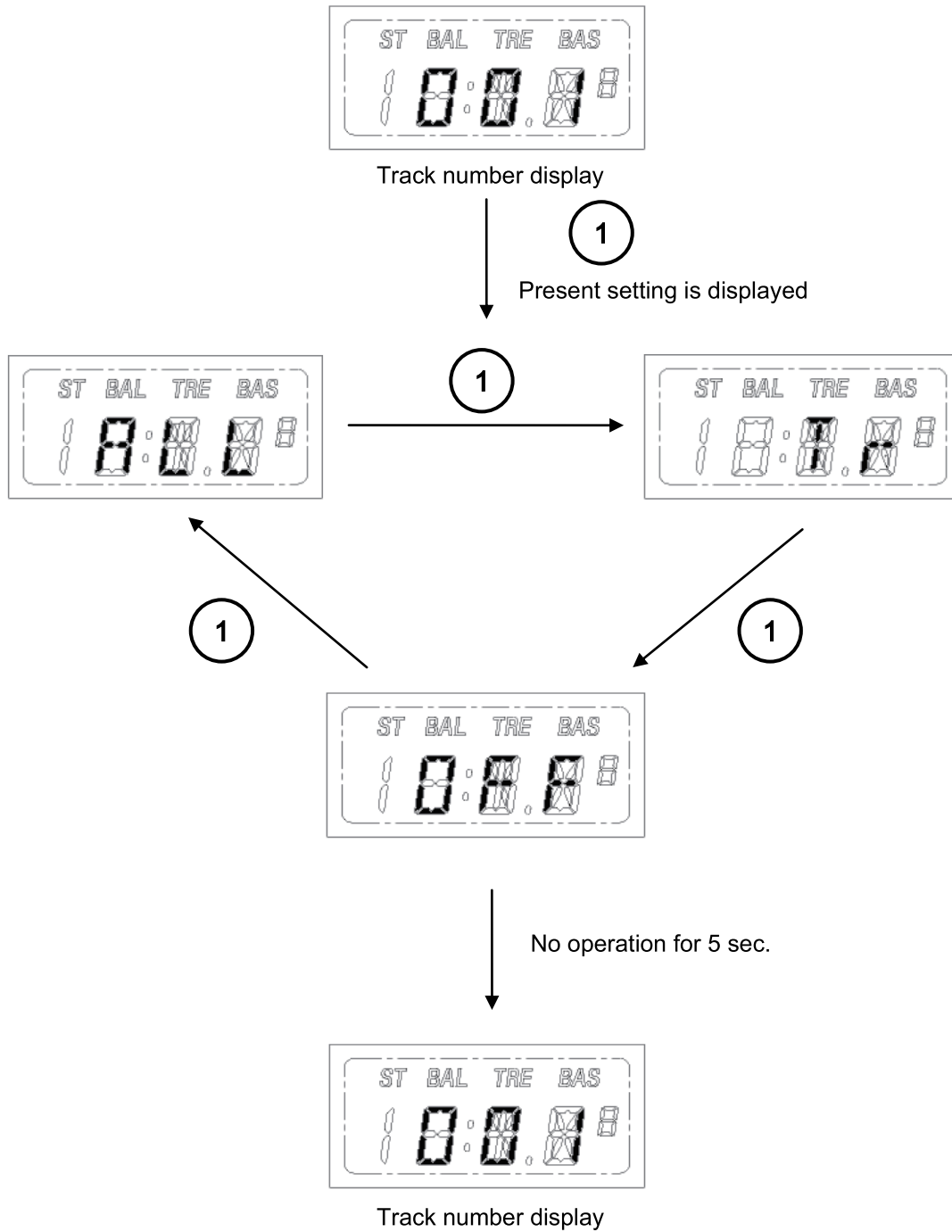

According to the iPhone/iPod, the order of change is different.  
Also, the display and the actual setting may be different.

RANDOM (USB)

While the USB memory is being played, press [PRESET 2] to display the present setting.  
Then, by pressing [PRESET 2], the setting is changed.

The range of the track being played  $\pm 128$  track files in the sorted order is played randomly.

As for the setting of repeat and random, the last setting is effective.

(In case of USB memory)

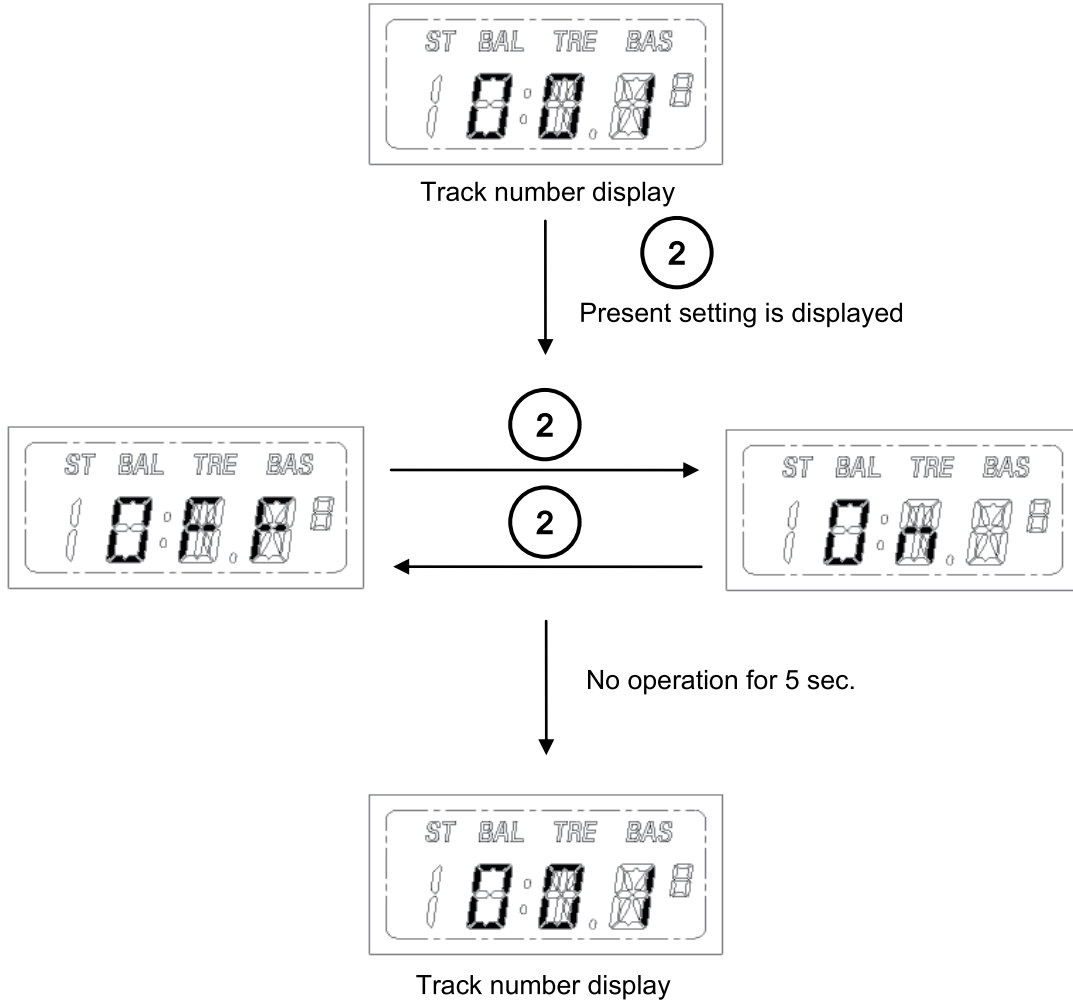

## [2. MACHINE FAMILIARIZATION]

(In case of iPhone/iPod)

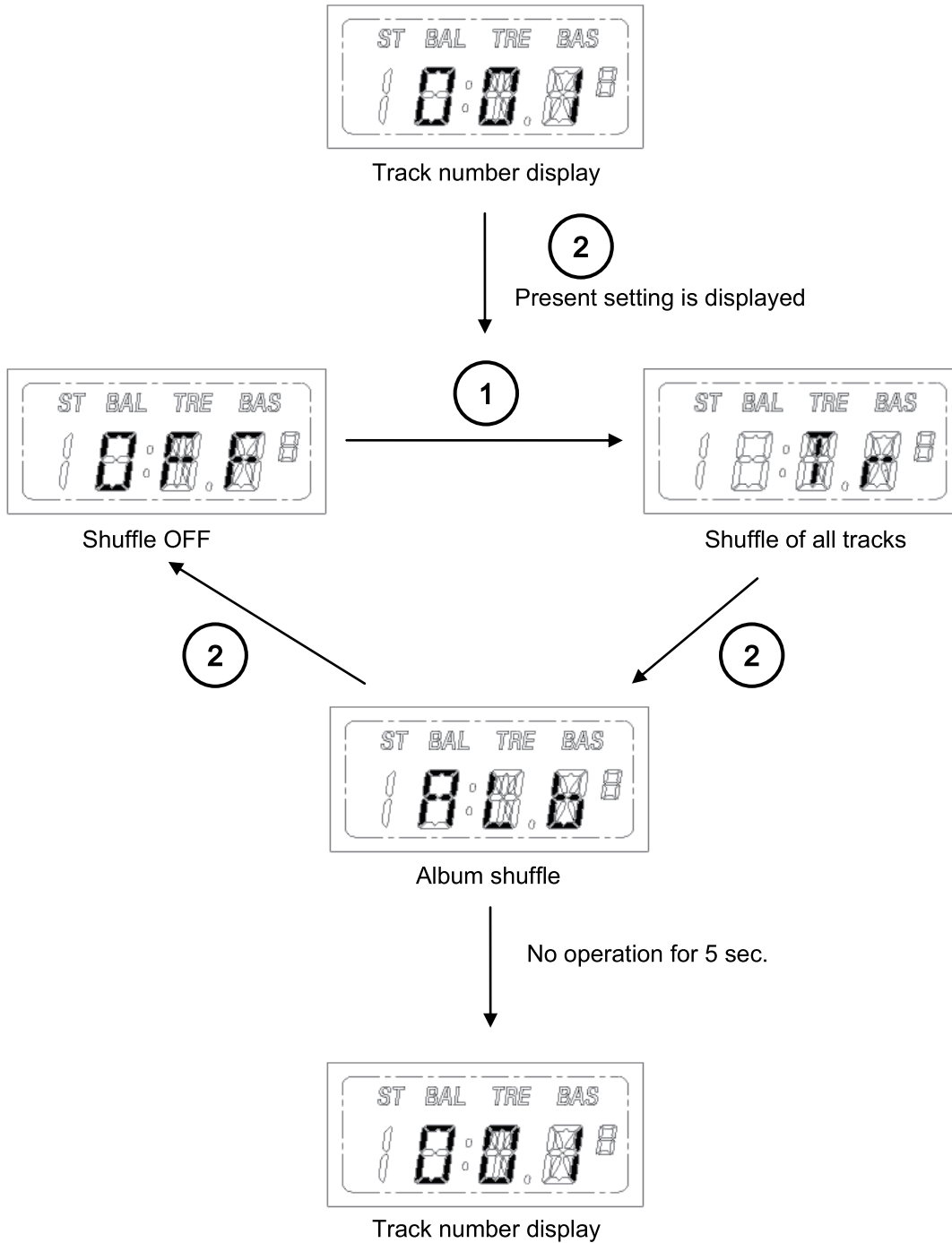

Depending on the type of the iPhone/iPod connected, the album shuffle is not available.  
(Depending on the type of the iPhone/iPod)

## 2.9.9 VOLUME CONTROL

If [VOL +] key is pressed under the on-air (normal) condition, the volume level is increased by 1 step.

The setting range is 0 to 32 steps.

Pressing and holding the key makes the volume increase consecutively.

By pressing [VOL -] key, the volume level is decreased by 1 step.

Pressing and holding the key makes the volume decrease consecutively.

Approximately 1.0 sec. after the finish of the operation, the display returns to the on-air condition.

As for the volume level, at the status of radio (AM/FM1/FM2), AUX, USB, and Bluetooth Audio, it is controlled respectively.

{As for "SOUND ADJUSTMENT" (TRE, BAS, BAL) described below, the radio, AUX, USB, and Bluetooth Audio are set commonly.}

{In case that selected band is FM1 (sound level of 11)}



Frequency display

(When stereo sound is received, "ST" pict turns on)



Volume level display



(Pressed and held)

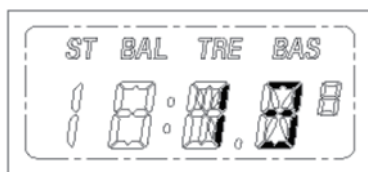

Volume level display



Volume level display



(Pressed and held)

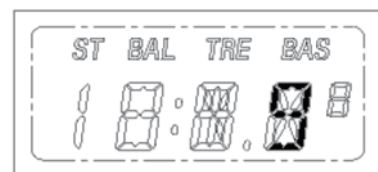

Volume level display

## 2.9.10 SOUND ADJUSTMENT

### SOUND ADJUSTMENT

With the radio component in the on-air (normal) condition, press [SOUND/PAIR] key to enter the sound adjustment. By pressing [SOUND/PAIR] key repeatedly, the adjustment item is switched through BAL→TRE→BAS. With the radio component in the BAS condition, by pressing [SOUND/PAIR] key, the sound adjustment status is canceled and the display returns to the on-air condition.

(In case that selected band is FM1)

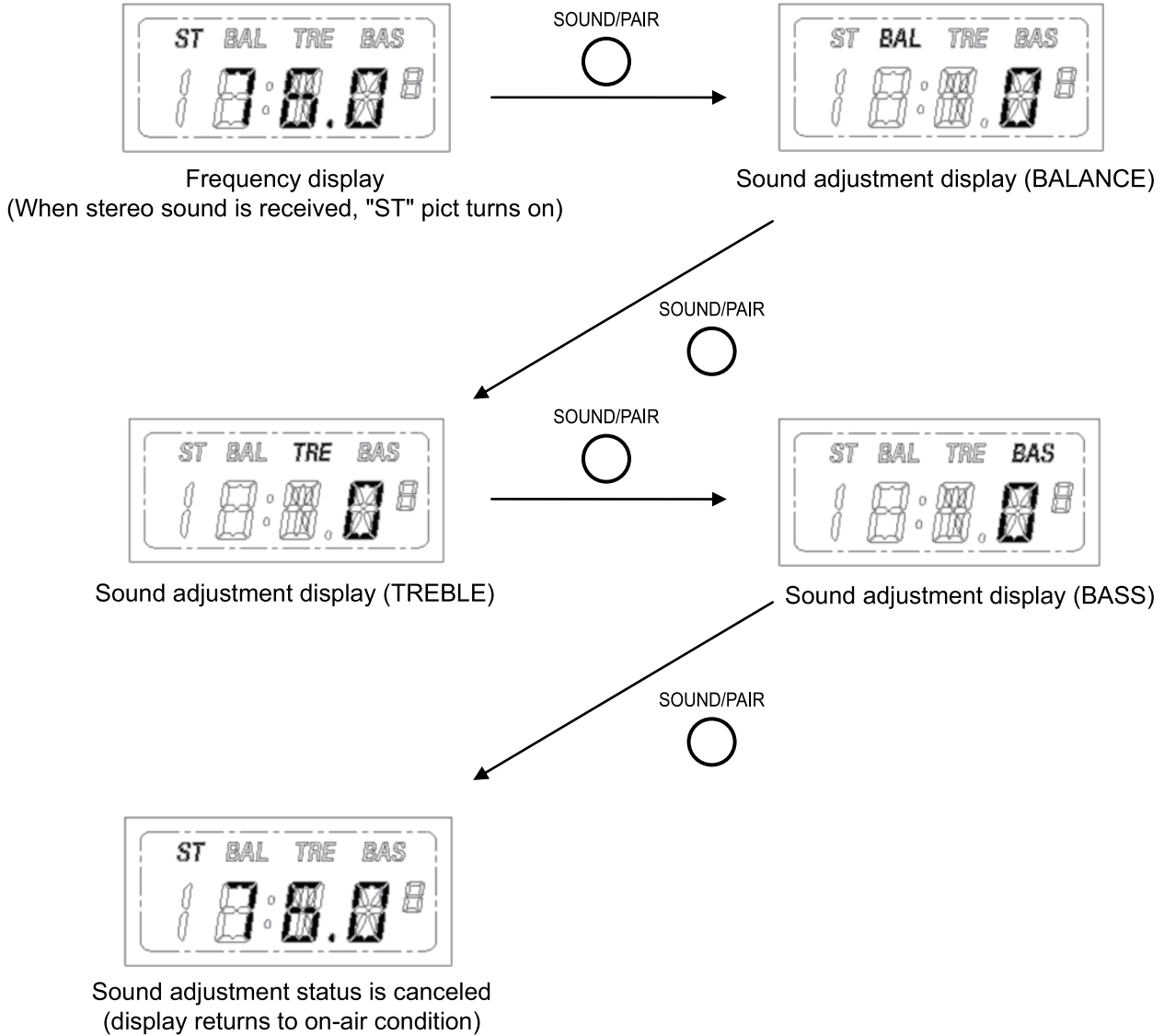

SOUND ADJUSTMENT (BALANCE)

With the radio component in the sound adjustment (balance) condition, press [UP] key to increase the speaker output by 1 step towards the R output.

Press [DOWN] key to increase the speaker output by 1 step towards the L output.

The setting range is L7 to R7 regarding 0 as the center. (L7 - 0 - R7)

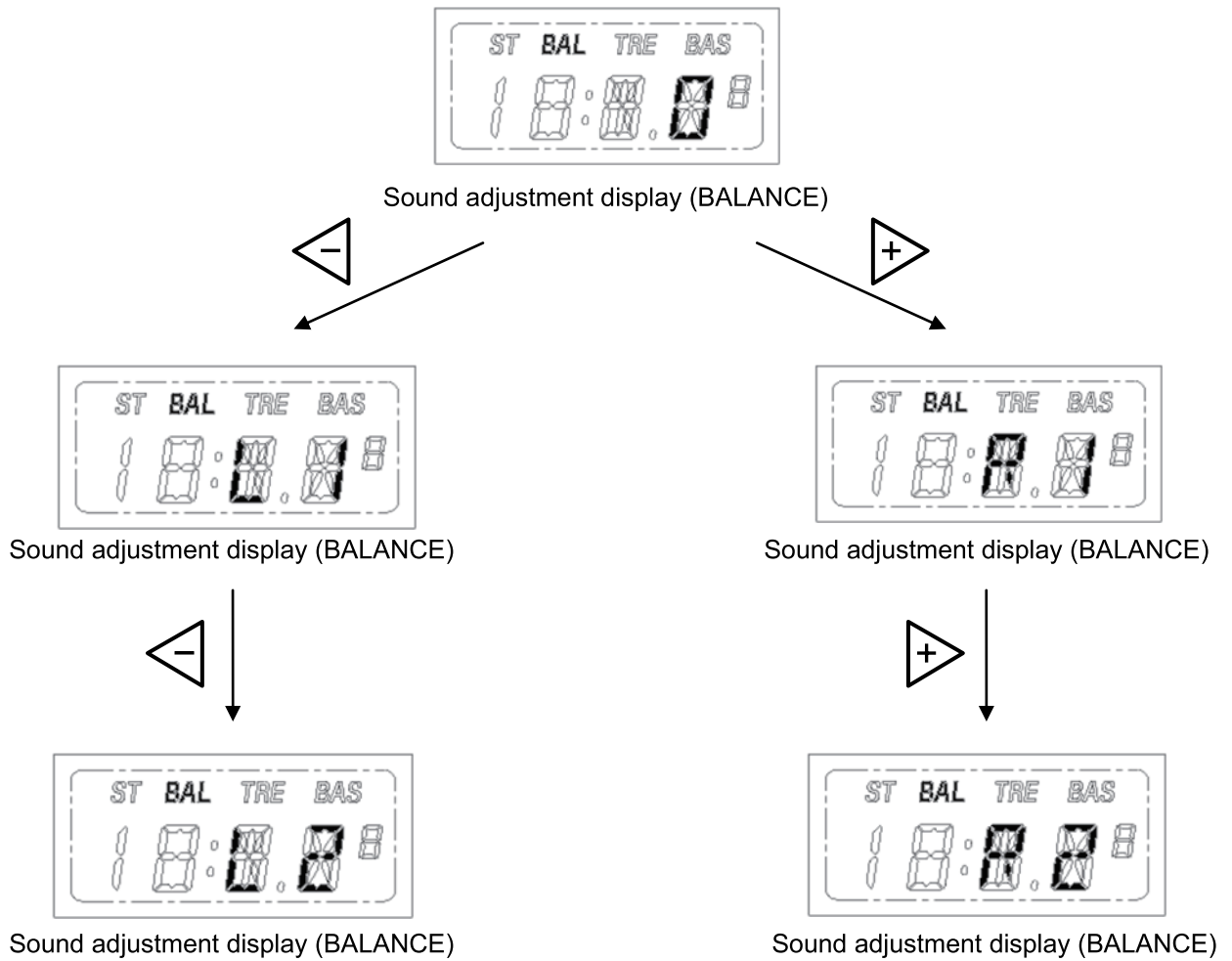

2

## [2. MACHINE FAMILIARIZATION]

### SOUND ADJUSTMENT (TREBLE)

With the radio component in the sound adjustment (treble) condition, press [UP] key to increase the treble level by 1 step.

Press [DOWN] key to decrease the treble level by 1 step.

The setting range is -7 to +7 regarding 0 as the center. (-7 - 0 - +7)

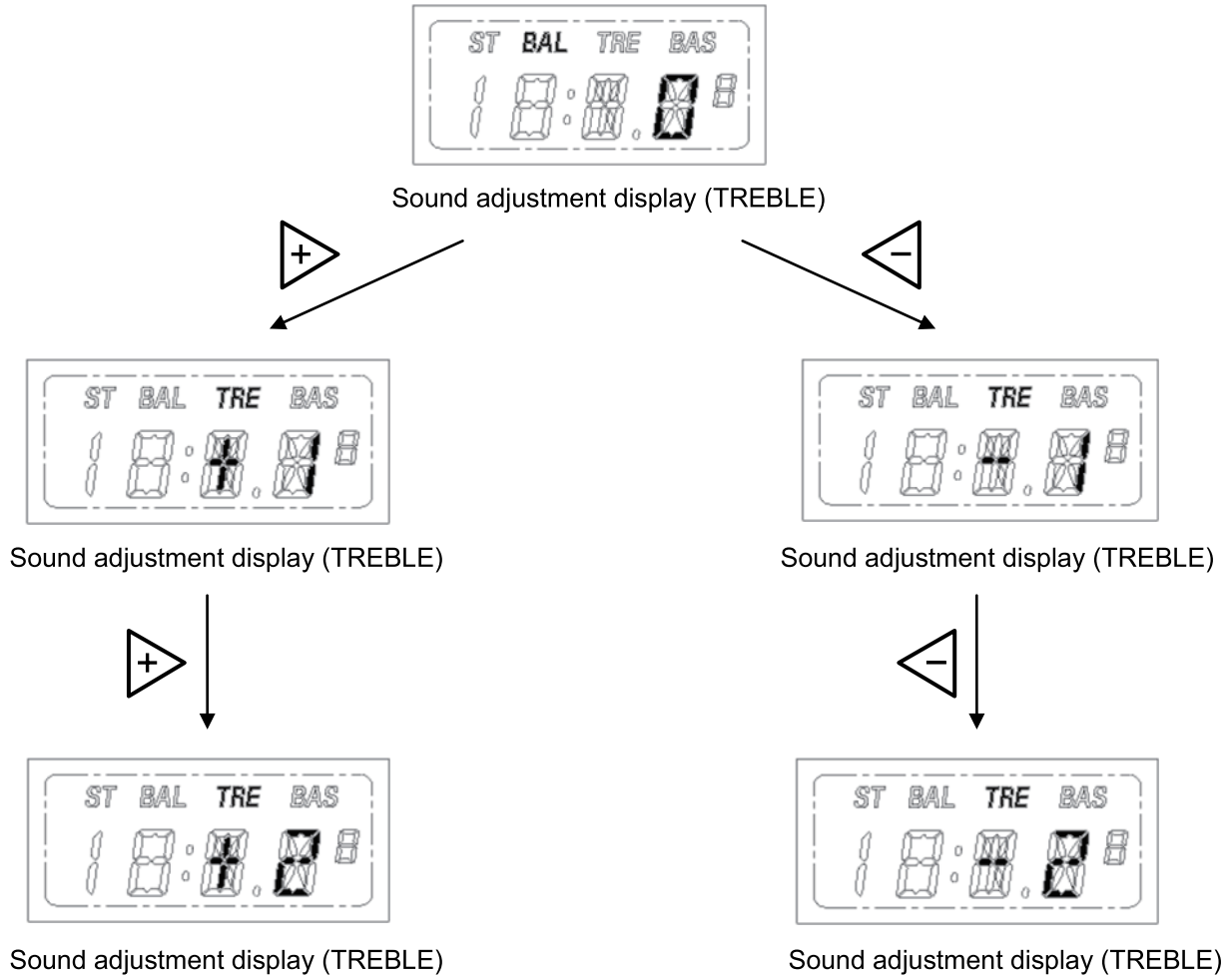



SOUND ADJUSTMENT (BASS)

With the radio component in the sound adjustment (bass) condition, press [UP] key to increase the bass level by 1 step.

Press [DOWN] key to decrease the bass level by 1 step.

The setting range is -7 to +7 regarding 0 as the center. (-7 - 0 to - 7)

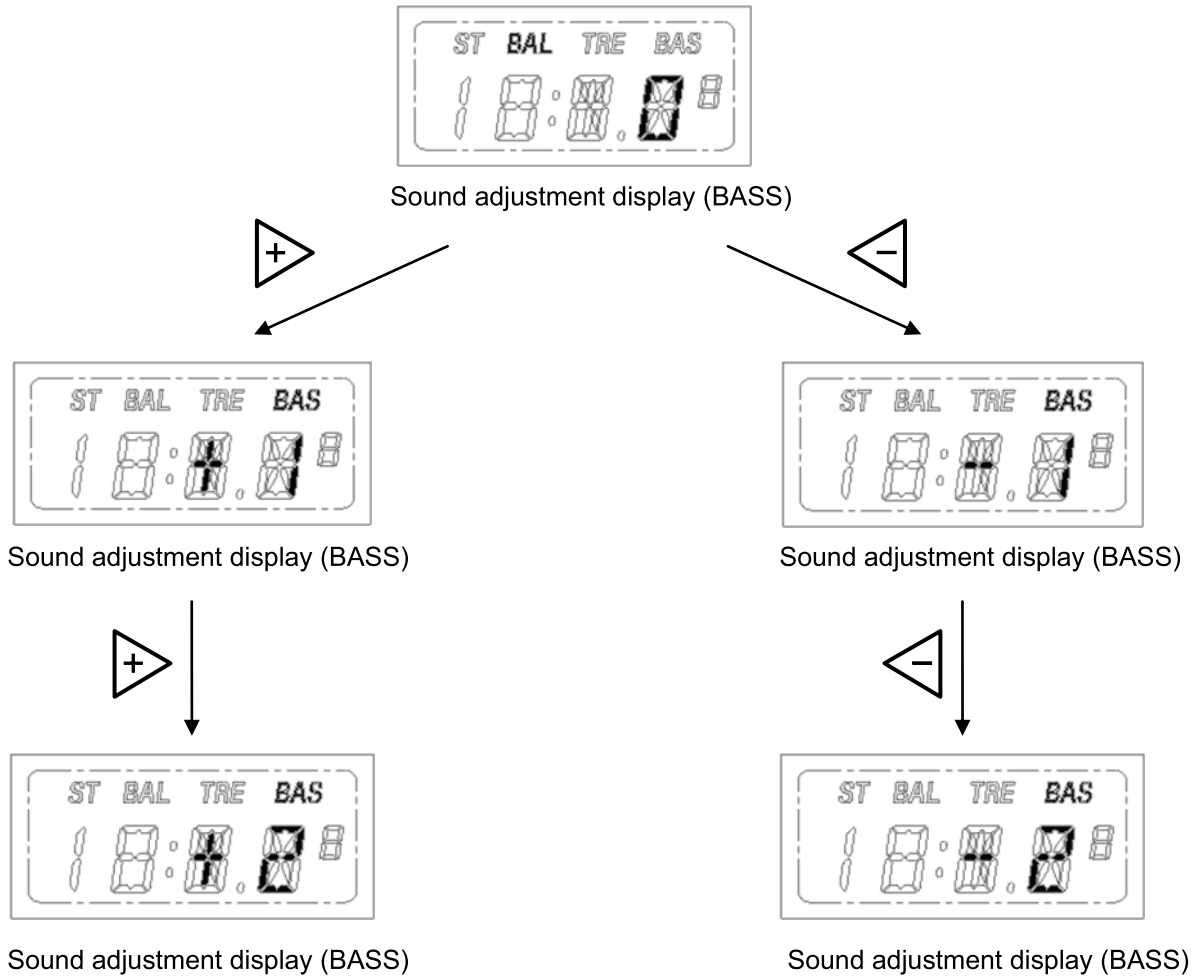

2

## 2.9.11 CLOCK ADJUSTMENT

With the radio component in the clock display condition, press [DISP] key to enter the clock adjustment.

In the clock adjustment, by pressing [DISP] key, the adjustment target changes from time to minute (the adjustment target blinks). Then press [UP] or [DOWN] key to adjust time and minute respectively.

With the radio component in the minute adjustment condition, by pressing [DISP] key, the clock adjustment status is canceled.

(From this time, the second counting starts internally.)

\* The clock display is 12 hours display.

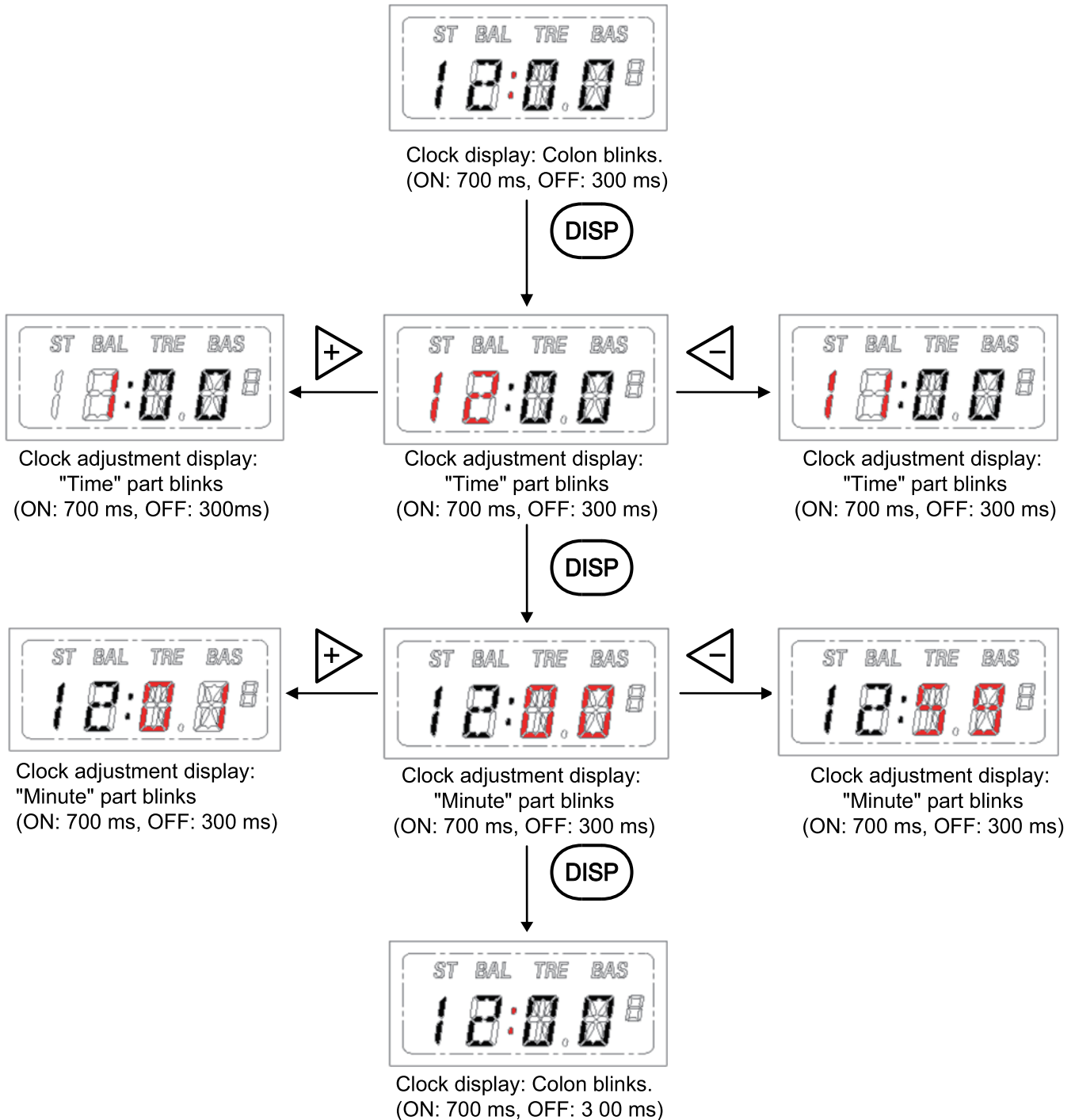

## 2.10 AIR CONDITIONER

The air conditioner can adjust the temperature inside the cab and dehumidify the cab.

The air conditioner is located under the cover at the back of the operator's seat and sends out warm and cool air in the cab.

### 2.10.1 GRILLE (AIR OUTLET)

Select air stream in preferable direction by hand.

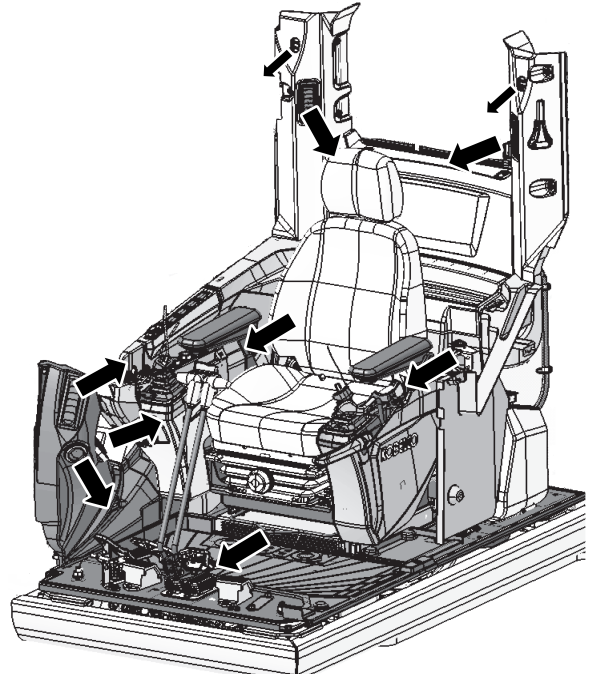

2

#### **CAUTION**

After replacing the parts, or charging or replacing refrigerant gas, break in the air conditioner.

When breaking in the air conditioner, be sure to set the engine speed to low speed.

Never start the air conditioner with the high engine speed. This might cause failure of the air conditioner.

2.10.2 AIR CONDITIONER CONTROL PANEL

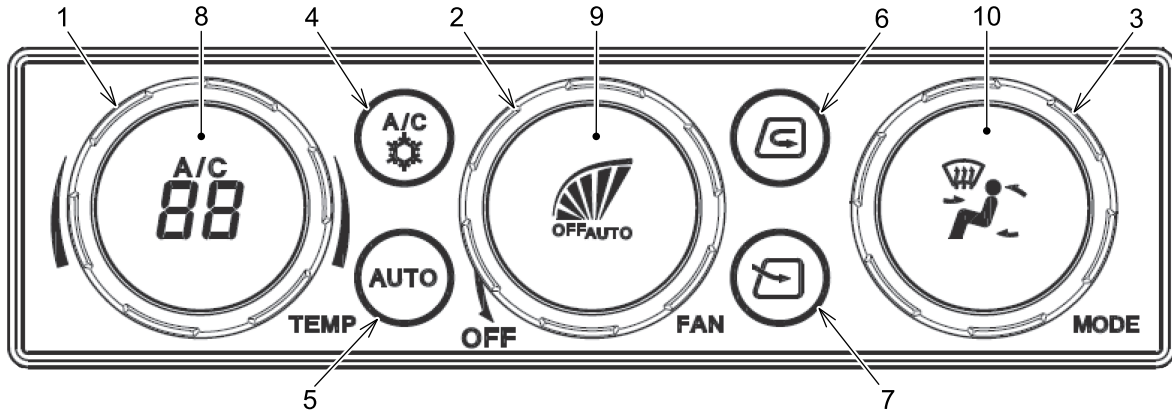

Item	Name	Item	Name	Item	Name
1	Temperature setting dial	5	AUTO control switch	9	(Fan speed/AUTO/OFF) LCD display
2	Fan speed selector dial	6	Recirculation air selector switch	10	(Air outlet mode) LCD display
3	Air outlet mode selector dial	7	Fresh air selector switch		
4	Compressor switch	8	(Temperature/A/C) LCD display		

**Notice**

- (Temperature/A/C) LCD display (8) displays temperature and ON/OFF of the compressor; (fan speed/AUTO/OFF) LCD display (9) displays blower fan speed, AUTO, and OFF; and (air outlet mode) LCD display (10) displays air outlet mode.
- Each of switches (4 to 7) turns on the indicator (amber) when the item is being selected.
- Each of switches (4 to 7) and displays (TEMP/FAN/MODE/COOL displayed in blue/HOT displayed in red) are equipped with illumination at night. (COOL displayed in blue, HOT displayed in red, and others displayed in white)

### 2.10.3 AIR CONDITIONER OPERATION PANEL

#### MAIN POWER SWITCH AND DISPLAY

- When the panel is OFF, "OFF" is displayed on (fan speed/AUTO/OFF) LCD display (9).
- When the panel is OFF, if fan speed selector dial (2) is operated clockwise, or AUTO control switch (5) is pressed down, the panel becomes ON and air conditioner control starts.

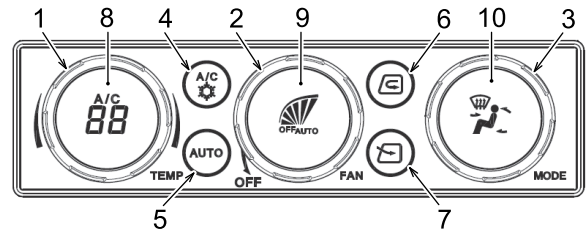

Operating fan speed selector dial (2) is operated clockwise: Operation starts with the fan speed Lo (manual) (other than the fan speed, the setting is the same as the previous operation)  
Pressing down AUTO control switch (5): FULL AUTO operation starts

- If the fan speed selector dial (2) is operated counterclockwise with the fan speed set to Lo, the panel becomes OFF.
- The air conditioner operation also turns OFF when the starter switch is turned OFF. However, if turned OFF with this switch, the status of the control panel just before turning OFF is sometimes not recalled when the starter switch is turned ON again.

#### FAN SPEED SELECTION AND DISPLAY

In the manual selection, (fan speed/AUTO/OFF) LCD display (9) is like the following.

Fan speed	Lo (Min. flow)	M1	M2	M3	M4	Hi (Max. flow)
LCD display						

By operating fan speed selector dial (2) in UP (turning clockwise) or DOWN (turning counterclockwise) direction manually, the AUTO control of fan speed is canceled, and "AUTO" on (fan speed/AUTO/OFF) LCD display (9) is turned OFF.

#### COMPRESSOR ON/OFF SWITCHING AND DISPLAY

When compressor switch (4) is pressed with "A/C" on (temperature/A/C) LCD display (8) turned OFF and the indicator of compressor switch (4) turned OFF, the compressor turns ON and then "A/C" on (temperature/A/C) LCD display (8) turns ON and the indicator of compressor switch (4) turns ON.

If the compressor switch is pressed again, the compressor turns OFF and "A/C" on (temperature/A/C) LCD display (8) and the indicator of compressor switch (4) turn OFF.

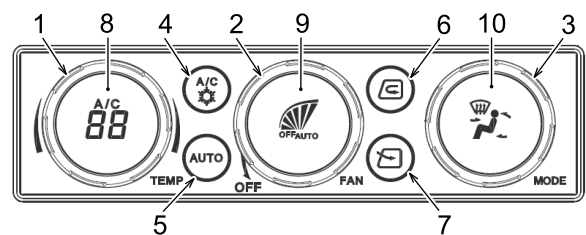

#### AUTO CONTROL SWITCHING AND DISPLAY

- "AUTO" on (fan speed/AUTO/OFF) LCD display (9) turns ON only when both the fan speed and the air outlet are under AUTO control.
- When AUTO control switch (5) is pressed, the fan speed and the air outlet become under the AUTO control, and "AUTO" on (fan speed/AUTO/OFF) LCD display (9) turns ON.
- When the panel is OFF, if AUTO control switch (5) is turned ON, the air conditioner function becomes ON. However, both the fan speed and the air outlet become AUTO control.

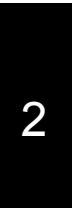
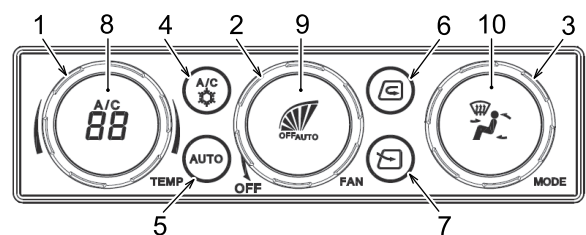

## [2. MACHINE FAMILIARIZATION]

### TEMPERATURE SETTING SELECTION AND DISPLAY

- The set temperature in digital display appears on (temperature/A/C) LCD display (8). The range of temperature setting is from 18 to 32 degrees C (64 to 90 degrees F).
- When changing the set temperature, operate temperature setting dial (1) clockwise (UP) or counterclockwise (DOWN)  
The increment and decrement of both UP and DOWN are 1 degree C.
- The set temperature of 18 degrees C (64 degrees F) is the maximum cooling and that of 32 degrees C (90 degrees F) is the maximal heating control. And the both control do not operate by targeting the set temperature.
- The set temperature display can be switched from/to degrees F to/from degrees C.  
With the panel turned ON, if recirculation air selector switch (6) and fresh air selector switch (7) are pressed simultaneously for 5 seconds or more, the "degrees F/C" display is switched (No unit is displayed).

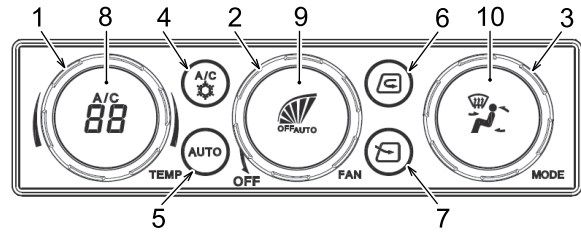

### LCD DISPLAY

Celsius (degrees C): LO, 19 to 31, HI

Fahrenheit (degrees F): LO, 65 to 89, HI

### RECIRCULATION AIR SELECTION AND DISPLAY

- With the fresh air intake condition {with the indicator of fresh air selector switch (7) turned ON}, if recirculation air selector switch (6) is pressed, it will switch the setting to recirculation air and the indicator of recirculation air selector switch (5) turns ON.
- With the recirculation air condition {with the indicator of recirculation air selector switch (6) turned ON}, if fresh air selector switch (7) is pressed, it will switch the setting to fresh air intake and the indicator of fresh air selector switch (7) turns ON.

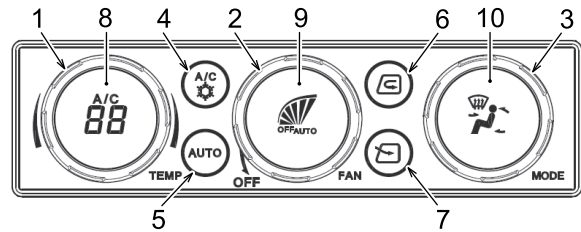

**AIR OUTLET MODE SELECTION AND DISPLAY**

- The current air outlet mode position is displayed with arrow(s) on (air outlet mode) LCD display (10).
- With "AUTO" turned ON, if air outlet mode selector dial (3) is operated, the mode displayed at that time is fixed. Then "AUTO" on (fan speed/AUTO/OFF) LCD display (9) turns OFF, and the AUTO control of the air outlet is released.

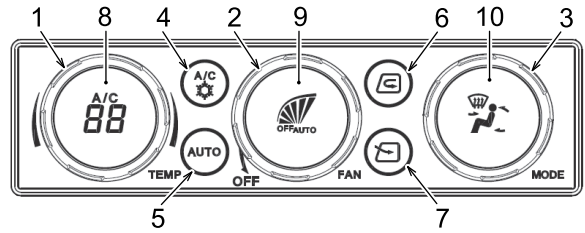

\* The AUTO control of the air outlet is also released even when only the air outlet is under the AUTO control (with "AUTO" turned OFF).

**<Air outlet mode and display>**

Mode	1	2	3	4	5
Air outlet mode	FACE	VENT	B/L	F/D	DEF
	Upper body (front side)	Upper body	Upper body and foot	Foot and front glass	Defroster
LCD display					

- When air outlet mode selector dial (3) is operated clockwise in the manual control, the mode is switched through Mode 1 → Mode 2 → Mode 3 → Mode 4 → Mode 5.
- When air outlet mode selector dial (3) is operated counterclockwise in the manual control, the mode is switched through Mode 5 → Mode 4 → Mode 3 → Mode 2 → Mode 1.



## [2. MACHINE FAMILIARIZATION]

### 2.10.4 HOW TO USE AIR CONDITIONER

Before turning the air conditioner on, close the doors and windows of the cab to achieve the best performance as an automatic air conditioner.

#### COOLING METHOD

##### Note

To avoid freezing of the evaporator, do not operate the air conditioner for a long time in the COOL-MAX set temperature with the LO airflow.

If it is frozen and cool air does not flow any longer, turn compressor switch (4) off, set the temperature high, operate the air conditioner with the maximum airflow "HI", and then turn compressor switch (4) "ON".

1. Operate fan speed selector dial (2) clockwise or press AUTO control switch (5).
2. Operate fan speed selector dial (2) clockwise and set the fan speed HI.
3. Operate temperature setting dial (1) and set a desired temperature.
4. Press compressor switch (4).
5. Press recirculation air selector switch (6) to select recirculation air.
6. Operate air outlet mode selector dial (3) and select the VENT outlet (mode 2).
7. When the temperature inside the cab becomes low, adjust the temperature and the fan speed to desired levels. When AUTO control switch (5) is pressed, the temperature, fan speed, and mode selection become automatic control.

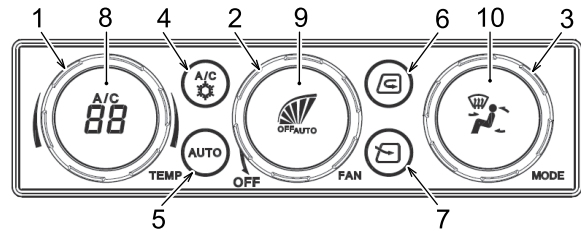

#### HEATING METHOD

##### CAUTION

The engine coolant is used for heating, and it is possible to heat the air when the temperature of the coolant is high.

1. Operate fan speed selector dial (2) clockwise or press AUTO control switch (5).
2. Operate fan speed selector dial (2) clockwise and set the fan speed HI.
3. Operate temperature setting dial (1) and set a desired temperature.
4. Press fresh air selector switch (7) to select fresh air intake.
5. Operate air outlet mode selector dial (3) and select the foot and front glass outlet (mode 4).
6. When the temperature inside the cab becomes high, adjust to the temperature and the fan speed to desired levels. When AUTO control switch (5) is pressed, the temperature, fan speed, and mode selection become automatic control.

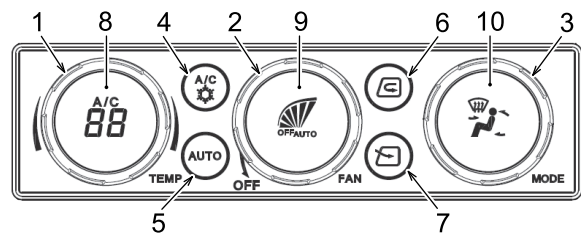



## METHOD OF HEATING WITH DEHUMIDIFICATION AND DEMISTING

**Note**

When the outdoor temperature is 0 degrees C (32 degrees F) or lower, the air conditioner (compressor) may not work.

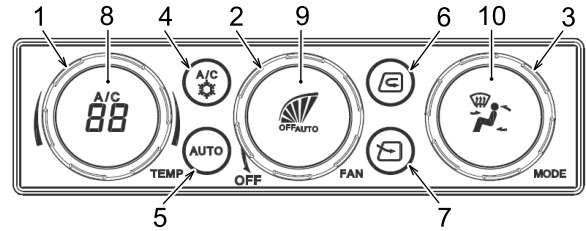

1. Operate fan speed selector dial (2) clockwise or press AUTO control switch (5).
2. Operate fan speed selector dial (2) and set a desired fan speed.
3. Operate temperature setting dial (1) and set a desired temperature.
4. Press fresh air selector switch (7) to select fresh air intake.
5. Press compressor switch (4) to operate the air conditioner (compressor).



## 2.10.5 SELF-DIAGNOSIS FUNCTION IN DISPLAY MONITOR



If there are problems on the input circuit of the driving line in the motor actuator, they can be checked on the panel display.

### <Display for detection of motor actuator disconnection/short circuit and motor lock>

Error	Error	
Air mix	· Displays "Er" on temperature display segment	
Air outlet mode	· Blinks human indication	
Switching recirculation air and fresh air	· Blinks indicators of recirculation air selector switch and fresh air selector switch	

When a failure occurs in the input circuit of the evaporator sensor or the recirculation air sensor, it can be checked by the panel display.

### <Display for detection of disconnection/short circuit of recirculation air sensor and evaporator sensor>

Error	Error	
Recirculation air sensor	· Displays "E*" on temperature display (last digit displays 0 to 9) · Turns off AUTO display	
Evaporator sensor	· Blinks A/C mark on (temperature/A/C) LCD display and indicator of compressor switch	

#### Error detection of each sensor from monitor mode function

- With the panel turned ON, if the compressor switch and the AUTO control switch are pressed simultaneously for 1 second or more, the display is switched to the monitor mode. To return to the previous display, perform the same operation.
- The normal status, disconnection, and short circuit of the recirculation air sensor and the evaporator sensor are shown in segment display.

<Contents of LCD display in monitor mode>

Display No.		Display data (displayed in 7 segments and 2 digits)	
No.	Fan speed in bar display	Display in decimal system (0 to 99) *A/C segment is OFF <b>88</b>	Display in hexadecimal system (0 to FF) *A/C segment is ON <b>A/C 88</b>
0		Recirculation air sensor Temperature (degrees C)	Recirculation air sensor AD value
1		Evaporator sensor Temperature (degrees C)	Evaporator sensor AD value

UP by recirculation air selector switch

DOWN by fresh air selector switch

Switched by compressor switch

		1st digit in segment display															
		0	1	2	3	4	5	6	7	8	9	A	B	C	D	E	F
2nd digit in segment display	0	Recirculation air sensor disconnection "0C" display															
	1	Evaporator sensor disconnection "0C" display															
	2	Each sensor is normal															
	3																
	4																
	5																
	6																
	7																
	8																
	9																
	A																
	B																
	C																
	D																
	E																
	F																
		Recirculation air sensor short "F6" Display															
		Evaporator sensor short "F6" Display															

<Contents of error display>

Sensor Name	Short Display	Disconnection Display
Recirculation air sensor	<b>F6</b>	<b>0C</b>
Evaporator sensor	<b>F6</b>	<b>0C</b>

2.10.6 HANDLING AT IN-SEASON/OFF-SEASON

**IN-SEASON**

To use the air conditioner for a long time comfortably, contact your KOBELCO authorized dealer for inspection and maintenance of the air conditioner at the beginning of in-season of cooling.

**OFF-SEASON**

During off-season, operate the air conditioner at least once a week for several minutes.

The oil shortage at each part of the compressor will be prevented by operating the air conditioner and it will always be kept in the best condition.

## 2.11 HANDLING OF SEAT BELT



### INSTALLATION OF SEAT BELT

- Be sure to fasten your seat belt during operation. If not followed, it can result in serious accidents or death caused by being heavily hit inside the cab or thrown out of the cab when the machine tips/rolls over.
- Check the mounting bolts installed to the seat for looseness and retighten the bolts if required.
- Change the seat belt every three years, even if there is no abnormality in the appearance. The manufacturing date is woven into the back side of the belt.

Since this seat belt is equipped with take-up motion, the adjustment of length is unnecessary.

### 2.11.1 HOW TO FASTEN SEAT BELT

1. Check that the seat belt is not twisted, and pull it out to a sufficient length.
2. Insert the seat belt into buckle (2) until it clicks. Release the seat belt, and the length is automatically adjusted and the buckle is locked.

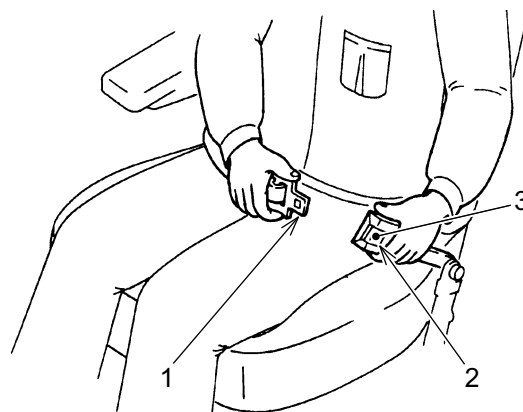

### 2.11.2 HOW TO UNFASTEN SEAT BELT

- Press the red button (3) of the buckle (2), and the belt (1) is unfastened.

## 2.12 HANDLING OF OPERATOR'S SEAT (AIR SUSPENSION SEAT)

Adjust the operator's seat to the position at which you can operate the control levers and pedals easily.

### **CAUTION**

When adjusting the operator's seat, pay attention to hands in order not to be caught between the handle and seat stand.

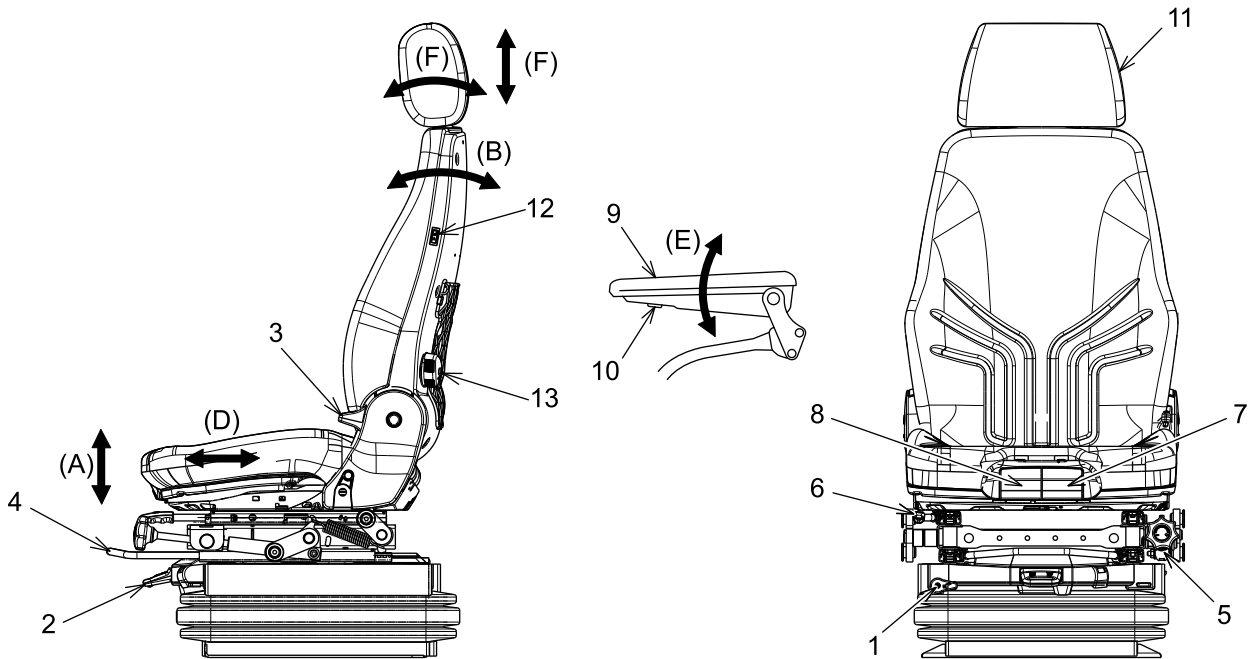

### 2.12.1 DAMPER ADJUSTMENT

The damper can be adjusted.

- Move handle (1) to a desired position. (3 steps)
  - a. Soft
  - b. Middle
  - c. Hard

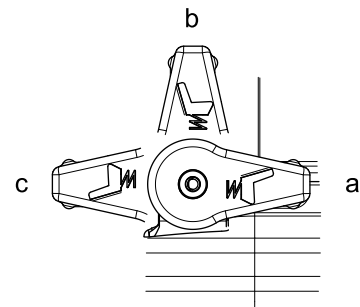

## 2.12.2 WEIGHT ADJUSTMENT

(A) The height of the operator's seat can be adjusted according to the operator's weight.

1. Pull up lever (2) shortly and then the seat height is automatically adjusted according to the operator's weight.
2. Release the lever to fix the height of the seat.

---

**Notice**

- Adjust the damper to the soft position before adjusting the seat.
  - Turn the starter switch to the "ON" position before adjusting the seat.
- 

## 2.12.3 HEIGHT ADJUSTMENT

(A) The height of the operator's seat can be adjusted.

1. Fully pull up lever (2).
2. Adjust the seat height to a desired height.
3. Release the lever to fix the height of the seat.

---

**Notice**

- Adjust the damper to the soft position before adjusting the seat.
  - Turn the starter switch to the "ON" position before adjusting the seat.
- 

## 2.12.4 RECLINING ADJUSTMENT

(B) The reclining angle can be adjusted.

1. Pull up lever (3).
2. Tilt the seat backrest to a desired angle.
3. Release the lever to fix the angle of the seat.

## 2.12.5 FRONT/REAR ADJUSTMENT OF CONTROL STAND

(C) The position of the whole control stand and operator's seat can be adjusted back and forth.

1. Pull up lever (4).
2. Move the seat back and forth to adjust it to a desired position.
3. Release the lever to fix the position of the control stand.

## 2.12.6 TILT ADJUSTMENT OF CONTROL BOX

The angle of the control box can be adjusted.

- Turn handle (5) to tilt the front side of the control box up or down.

### 2.12.7 FRONT/REAR ADJUSTMENT OF SEAT

(D) The position of the operator's seat can be adjusted back and forth.

1. Pull up handle (6).
2. Move the seat back and forth to adjust it to a desired position.
3. Release the handle to fix the position of the seat.

### 2.12.8 TILT ADJUSTMENT OF SEAT SEATING SURFACE

(A) The angle of the seating surface of the operator's seat can be adjusted.

1. Pull up handle (7).
2. Tilt the seat seating surface to a desired angle to adjust it.
3. Release the handle to fix the position of the seat seating surface.

### 2.12.9 FRONT/REAR ADJUSTMENT OF SEAT SEATING SURFACE

(D) The position of the seating surface of the operator's seat can be adjusted back and forth.

1. Pull up handle (8).
2. Move the seat seating surface back and forth to adjust it to a desired position.
3. Release the handle to fix the position of the seat seating surface.

### 2.12.10 ARM REST ADJUSTMENT

(E) The arm rest can be lifted up, and its angle can be adjusted.

- Arm rest (9) can be lifted up backward.
- Turn control dial (10) at the bottom of arm rest (9) by hand to adjust the angle of the arm rest in the regular position.

### 2.12.11 HEAD REST ADJUSTMENT

(F) The head rest can be adjusted by moving it up, down, back, or forth.

- To adjust head rest (11) up or down, hold it with both hands, and move it up or down slightly.
- To adjust head rest (11) back and forth, hold it with both hands, and move it back and forth to a desired position.

### 2.12.12 SEAT HEATER

Turn seat heater switch (12) "ON" to warm the seat.

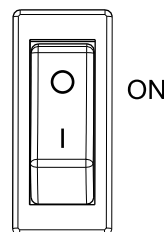

#### Notice

This function can be used with the starter switch "ON".

### 2.12.13 LUMBAR SUPPORT

Adjust the lumbar supporting level of the backrest by using adjusting dial (13) of the lumbar support.

## 2.13 HANDLING PARTS INSIDE CAB



### LEAVING OPERATOR'S SEAT

Do not leave the cab with the engine running.

When necessary to leave the operator's seat, be sure to lock the control lock lever and then stop the engine.

If the control lever is unexpectedly touched without the control lock lever locked, it may cause severe accident resulting in severe injury.

### 2.13.1 CAB DOOR LOCK



In operation, lock the door securely either open or close. If not locked, the door may open or close unexpectedly and this may cause danger and failure of the machine.

This procedure is used to securely lock the door in open position.

- Push the door against catch (1) and check that it is locked securely.
- To close the door, move lever (2) on the left side of the operator's seat to the direction of the arrow and then the catch is released.

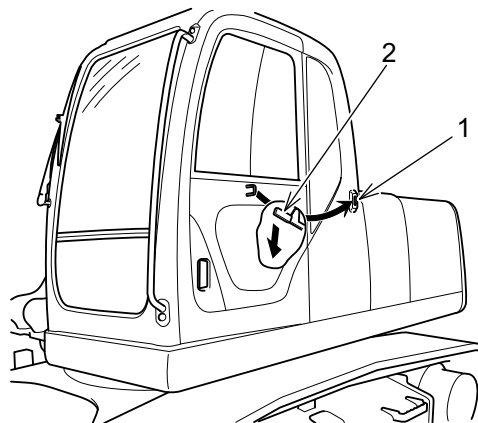

### 2.13.2 OPENING DOOR FROM INSIDE OF CAB

- To open the door from the inside of the cab, move lever (1) to the direction of the arrow.

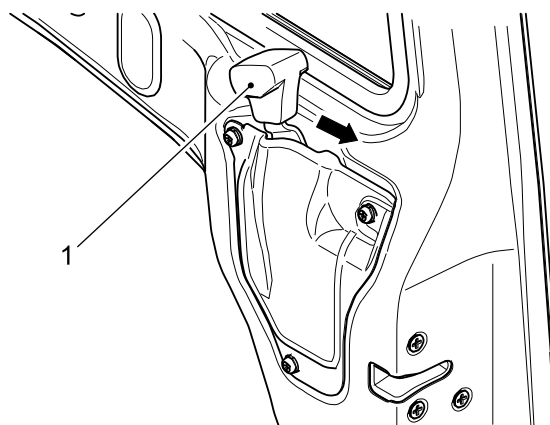



### 2.13.3 OPENING/CLOSING FRONT WINDOW (UPPER)



#### OPENING/CLOSING FRONT WINDOW (UPPER)

- Opening/closing the front window with the machine in a level position and lock the front window securely. If the lock is released in the forward tilting position of machine there is a possibility of falling of the front window.
- When closing the front window, the closing speed increases due to the weight of front window. Hold and close it by both hands securely.
- When opening/closing the front window in, pull up the control lock lever to the "LOCKED" position and stop the engine.



To prevent your hand from being caught between the windows, open and close the front window slowly. It is dangerous to work with the front window not or incompletely locked. Confirm that the front window is surely locked.

1. Move the machine to a level and firm place.
2. Put the bucket on the ground.
3. Stop the engine and move the control lock lever to the "LOCKED" position.

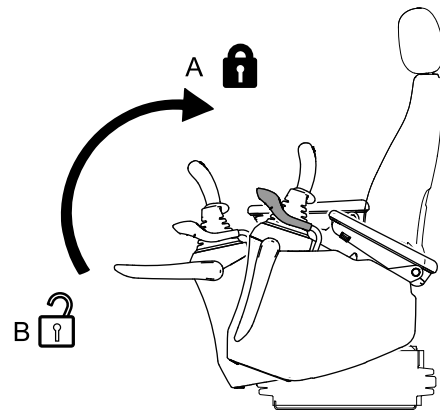

4. Push lock lever (1) on the center of the front window (upper) right to release the lock.

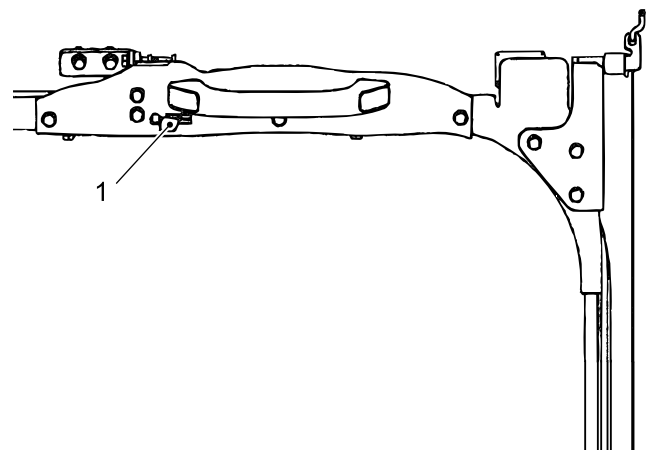

## [2. MACHINE FAMILIARIZATION]

5. Hold and lift up the handles(2) on the upper and lower part of the front window (upper), and move the front window (upper) fully toward the back of the ceiling to automatically set it to the locked condition; however, check it is locked securely.

### **When closing front window**

1. Hold handles (2) at the upper and lower parts of the front window (upper) and push lock lever (1) right to release the lock.
2. When the front window (upper) is returned to the original position, it is locked automatically. However, check that the window is securely locked.

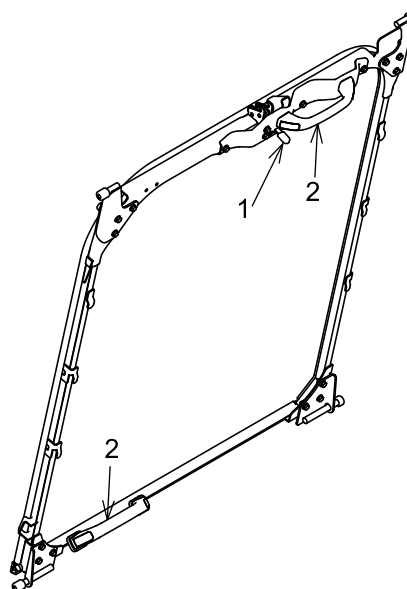

### 2.13.4 REMOVING FRONT WINDOW (LOWER)

1. After open the front window (upper) in the ceiling, hold the front window (lower) by hands and remove it from the window frame. The removed front window (lower) should be stored in holder (1) on the left back side of the cab for secure storage.
2. Insert the glass into right and left holders (1), and fix the glass with lock (2) on the upper window frame.

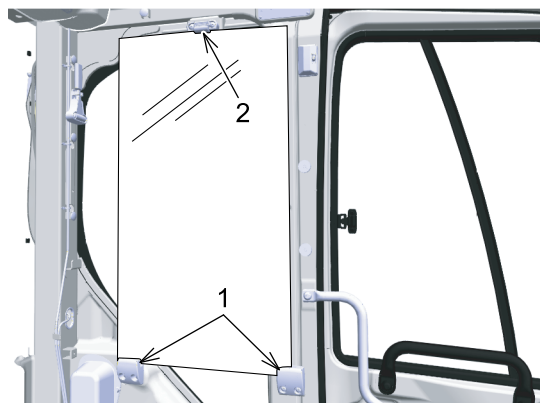

### 2.13.5 ROOM LAMP

Operate switch (1) in accordance with the purpose.

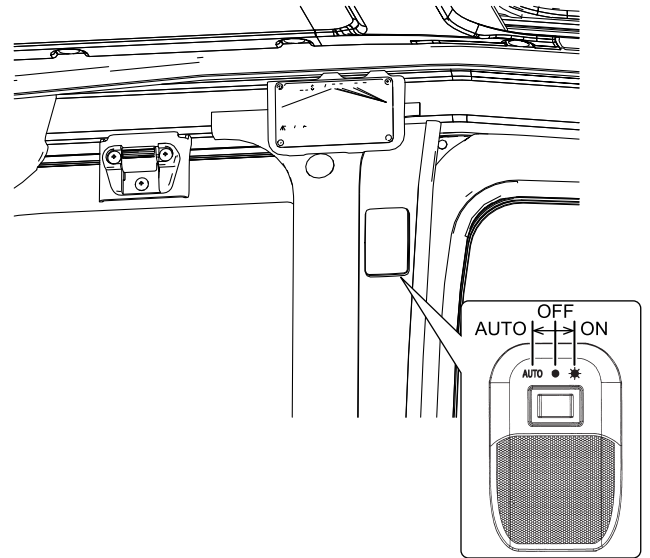

Switch	Contents
AUTO	The room lamp turns on for 25 seconds after the door is opened. For 25 seconds after the door is opened, the room lamp keeps turning on even if the door is closed.
OFF	The room lamp does not turn on.
ON	The room lamp turns on.

## 2.14 EMERGENCY ESCAPE FROM OPERATOR'S STATION

If it is impossible to open the cab door in an emergency, escape from the cab by the following way.

1. Open the front window and escape through the front window.

**Notice**

For how to open the front window, see "OPENING/CLOSING FRONT WINDOW" in Chapter 2.

2. If the front window cannot be opened, break the front or rear window glass by using hammer for emergency exit (1) placed on the left rear of the cab.

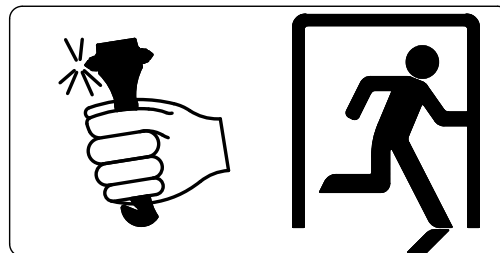
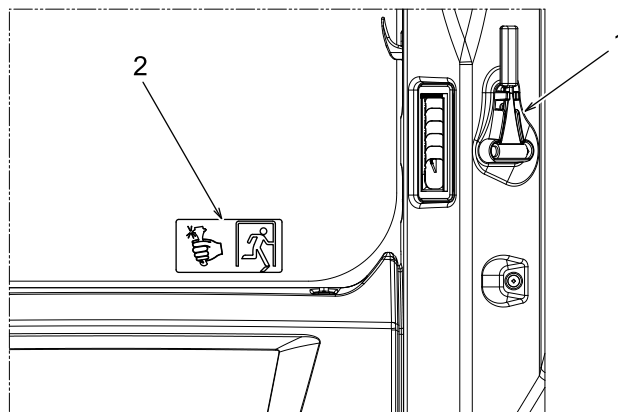

**CAUTION**

Pay attention to the broken pieces so as not to be injured when breaking the window glass.

**Notice**

Label (2) indicating the emergency exit are affixed on the rear window.

## 2.15 OTHER ACCESSORIES

### 2.15.1 TOOL BOX

Use the tool box for storing tools and fixtures. The storage place is on right side (1) of the machine.

Use the starter key to release the lock on the door, and hold it with the stay.

After using tools, remove the stay, close the cover, and lock it with the starter key.

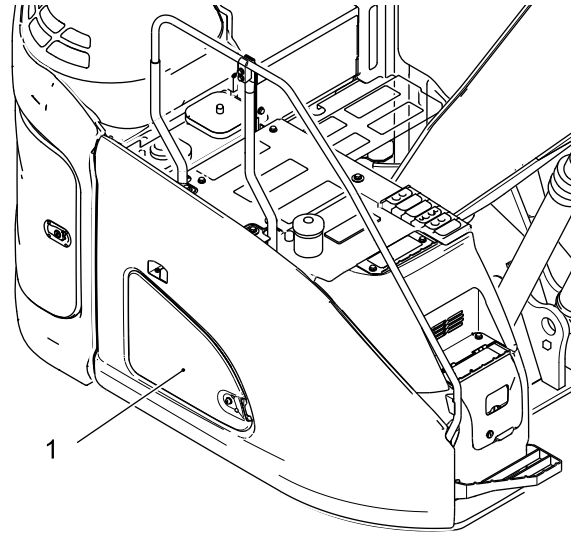

2

### 2.15.2 GREASE GUN HOLDER

This is on the left rear of the machine.

When the gun is not used, put it on this holder.

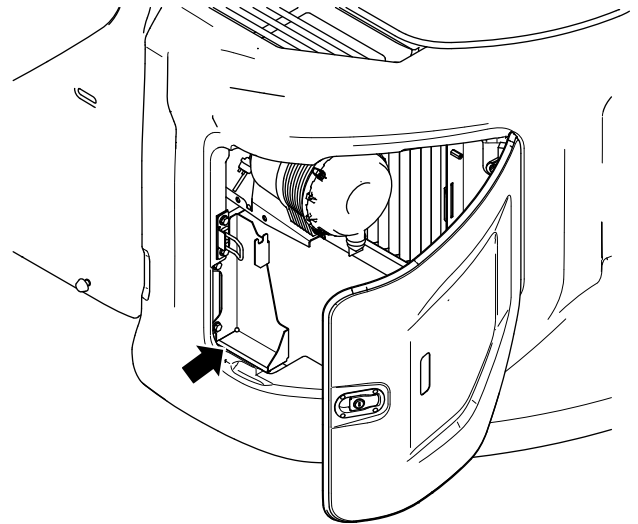

### 2.15.3 GUARD/SIDE DOOR (WITH LOCK)

#### **CAUTION**

Be sure to stop the engine before opening the engine hood, battery cover, and side cover, etc.

The engine hood, fuel inlet, right and left side doors, and cab door covers are provided with the lock mechanism. To open/close them, use the starter key. When using the starter key, fully insert it and then turn it. If it is not fully inserted, it may be broken.

## [2. MACHINE FAMILIARIZATION]

### HOW TO UNLOCK AND OPEN GUARD AND SIDE DOOR

1. Insert the starter key into the keyway.



2. Turn the starter key counterclockwise and pull the door handle to open the door.
3. If the door is provided with a stay, support the door securely using the stay.

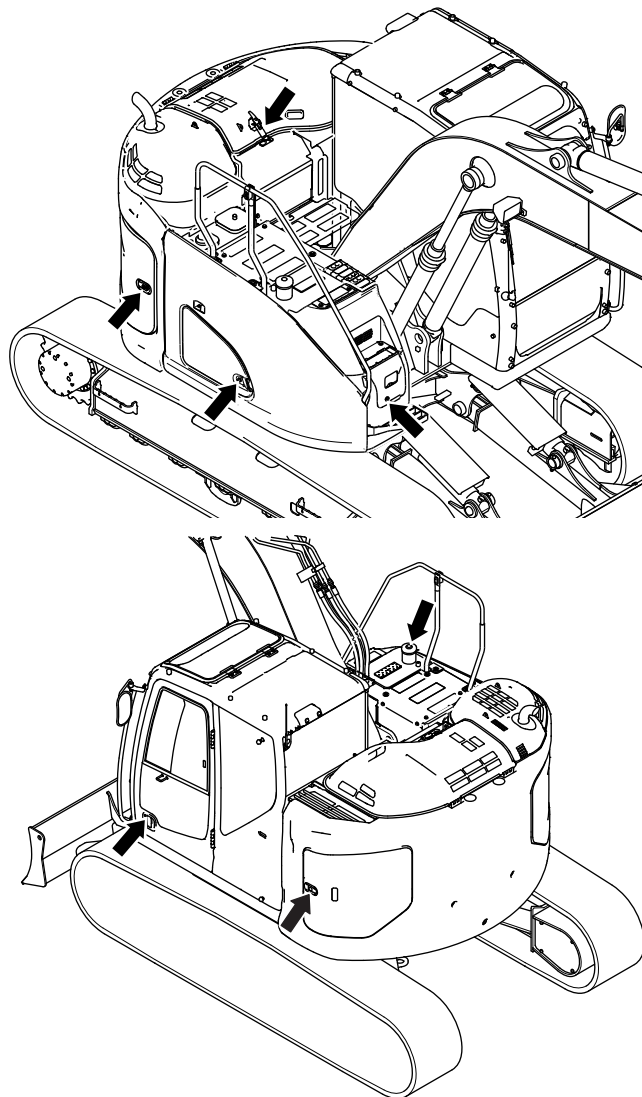

### HOW TO LOCK GUARD AND SIDE DOOR

1. If a stay is provided, return the stay to the original position.
2. Close the door.
3. Turn the starter key clockwise and remove it.

## 2.16 BATTERY POWER-OFF SWITCH

### **CAUTION**

When turning the battery power-off switch to the "O (OFF)" position, turn the starter switch to the OFF position and wait 5 minute or more. And then operate the battery power-off switch.

If the cover of the battery power-off switch is opened within five minutes after the starter switch is turned OFF, the buzzer starts sounding.

If the battery power is turned off immediately after the engine is stopped, it may cause damage to the electric devices.

### **Notice**

When setting the switch to the OFF position, all electrical circuits are shut down, and the preset memory and clock memory of the radio are cleared.

The battery power-off switch shuts down the battery circuit.

The switch is located on the right of the opened left side door. It is usually set to the "I (ON)" position.

ON(I): Turn key (1) right to connect the electrical circuit.

OFF(O): Turn key (1) left to shut down the electrical circuit.

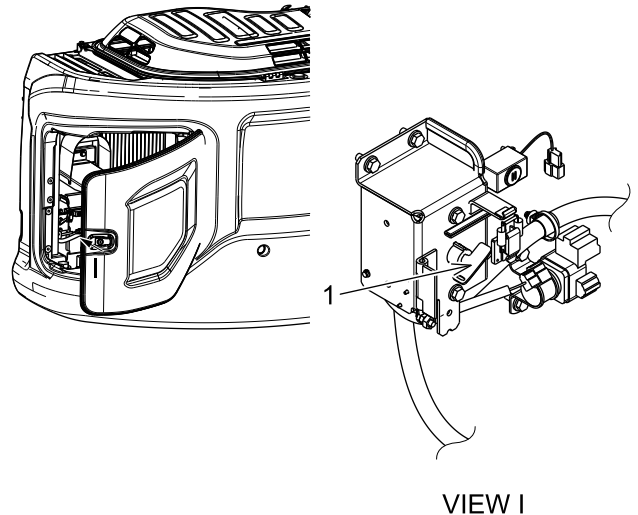

### **Notice**

Set the battery power-off switch to "OFF" for the following purposes:

#### **To stop operation of the machine for a long period (one month or longer)**

Shut down the power circuit to prevent battery discharge, short circuit, or electric leakage.

#### **To perform maintenance of the electrical system or electric welding**

Shut down the power circuit to prevent damage of electrical components, fire and so on.





# 3. MACHINE OPERATION



## 3.1 DAILY MAINTENANCE CHECKS

Before starting the engine, walk around the machine to check for any loose nuts and bolts, any oil, fuel or coolant leakage, and the condition of the attachment/equipment, body structure, and hydraulic system.

Check for any looseness in the electrical wiring and for any accumulated material (leaves, dirt, etc.).



### WARNING MACHINE FIRE PREVENTION

The deposit of flammable, fuel leakage and oil leakage in heated area around the engine, muffler and battery may cause fire of machine. Check the area sufficiently, and if the abnormality is found, repair it or contact your KOBELCO authorized dealer.

- Clean all slippery substances such as grease, oil, hydraulic oil, mud, ice, and others attached to the steps, handrails, crawlers, ladders, and platforms.
- Check the engine for any oil, fuel or coolant leakage. Repair as required.
- Check the area around the engine and radiator for any accumulated material and remove as required.
- Check the hydraulic devices, hydraulic oil tank, hoses and joints for oil leakage, and repair as required.
- Check the travel system, such as the crawler, front idlers and sprockets, for any damage or wear, and the bolts for looseness, and the rollers for oil leakage, and repair as required.
- Check the attachment/equipment, body structure, and cylinders for any cracking, damage or looseness, and repair as required.
- Check the doors, covers, steps and handrails for damage, and the bolts for looseness. Repair any damages and tighten loose bolts.
- Check the monitor for damage and replace it as required.
- Check the rearview mirrors for abnormality and replace it with a new one when it is broken. Clean the surface of the mirror and adjust the angle so that the operator can see the rear from the operator's seat.
- If the machine is equipped with the rearview camera and the side cameras, clean the lenses to display clear images from the rearview and side cameras to the monitor.
- Check the seat belts and the mounting hardware for the abnormality and if any damage is found, replace it with a new one.

### 3.1.1 SUPPORT STAY

The support stays are provided on the side doors and the engine hood.

When opening the side doors and the engine hood, be sure to fix them with the stays



### CAUTION

Before performing inspection or maintenance, be sure to fix the opened side doors and the opened engine hood with the support stays to prevent them from moving, resulting in personal injury.

#### Stay fixed by hole

Open the door, and put stay (1) into fixing hole (2) to fix the stay.

Before closing the door, remove the stay from the fixing hole, return it to the original position, and then close the door.

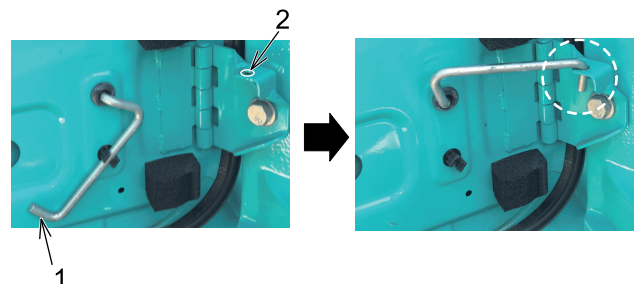

### [3. MACHINE OPERATION]

---

#### Slide type stay

Open the door, slide stay (1) to fixing part (2) of the guide to fix the stay.

Before closing the door, remove the stay from fixing part (2) and then close the door.

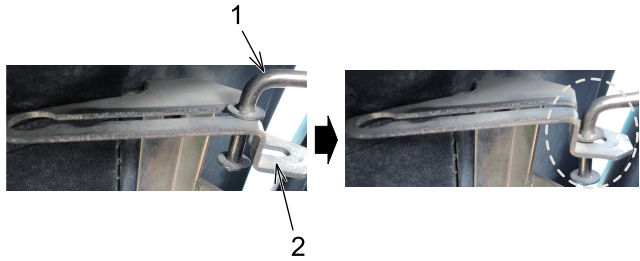
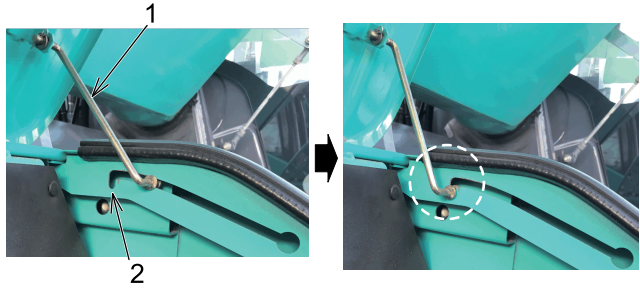

## 3.2 CHECK BEFORE STARTING ENGINE

The following checkup should be performed once before the first engine startup in a day.

### 3.2.1 CHECKING COOLANT LEVEL AND REFILLING



#### HANDLING OF RADIATOR

- Do not open the radiator cap if not required. Check the coolant of reserve tank (1) when the engine is cooled down.
- After the engine stops, the coolant is hot and the high pressure is accumulated in the radiator. Removing the radiator cap under this condition may cause burns. After the coolant cools down, turn the cap slowly to release the pressure.
- If the water level in the reserve tank drops frequently, immediately contact your KOBELCO authorized dealer.

1. Use the starter key to open the side door on the left side of the machine and hold it with the stay.
2. Check that the coolant level falls within the range of FULL (upper limit)-LOW (lower limit) of reserve tank (1). If the water level is low, remove the cap of filler port (2) of the reserve tank and pour coolant water to the FULL level.  
If the reserve tank is empty, check it for water leaks and check the water level in the radiator. If the water level is low, fill the radiator with coolant and then fill the reserve tank with coolant. Then immediately contact your KOBELCO authorized dealer.
3. After supply, tighten the cap securely.
4. Release the support stay and close the side door.

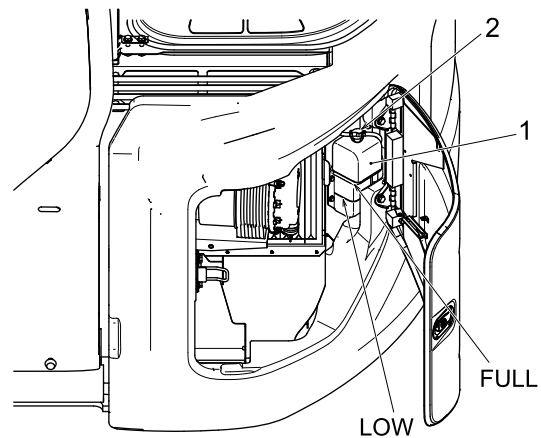

### 3.2.2 CHECKING ENGINE OIL LEVEL OF ENGINE OIL PAN AND REFILLING



#### TEMPERATURE AFTER STOPPING ENGINE

Immediately after the engine is stopped, there is a possibility of getting burn with heated parts and oil. Start working after the temperature goes down.

#### Notice

- Make sure the machine is in a level and firm condition when checking the engine oil level.
- Be sure to check the engine oil level before starting the engine.
- When checking the engine oil level after operation, wait approximately 30 minutes from engine stop before checking it.

1. Open the engine hood with the starter key and hold it with the stay.
2. Pull out oil level gauge (1) and wipe off the oil with a waste cloth.
3. Insert oil level gauge (1) completely once again and pull it out.

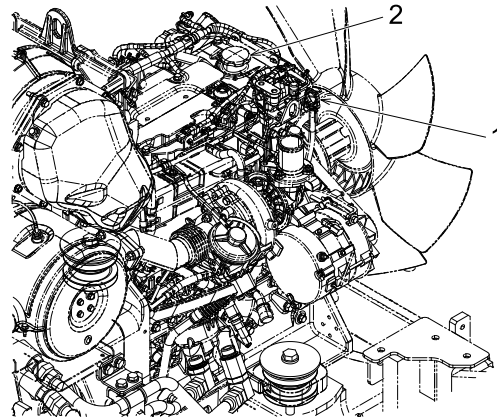

4. When oil level gauge (1) indicates the oil level between "FULL" (upper limit) and "ADD" (lower limit), it is proper. When the oil level does not reach "ADD" level, refill the engine oil from oil filler cap (2). If the oil is significantly contaminated or deteriorated, change it ahead of the periodic replacement interval. For engine oils to use, see "LUBRICANT, FUEL & COOLANT SPECIFICATIONS" in Chapter 4.

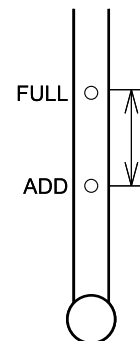

5. When the oil level is above the "FULL" level, loosen drain cock (3) to drain the excess engine oil and check the oil level once again.

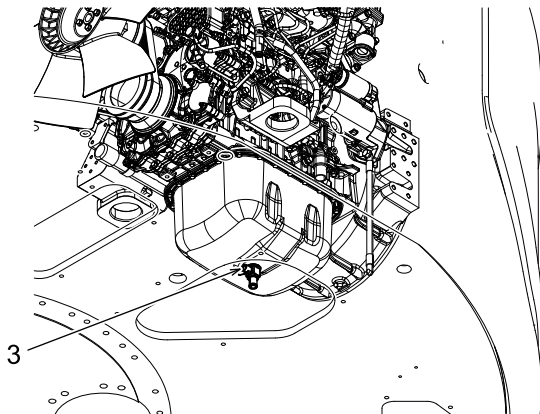

6. Check that the oil level is proper and insert level gauge (1) securely.

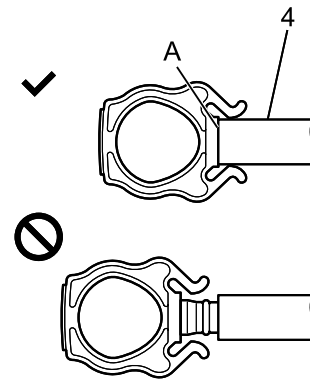

**Notice**

- When inserting the oil level gauge (1), be careful not to bend it. Otherwise, the oil level gauge (1) may be deformed.
- Insert the oil level gauge (1) until the grip part (A) touches the guide tube (4). A gap between them may let water enter the engine causing a malfunction.

7. Remove the support stay and close the engine hood.

### 3.2.3 CHECKING FUEL LEVEL AND REFUELING



#### REFUELING

- Never use the oil other than diesel fuel as fuel. Check the fuel type again before refueling.
- Be sure to stop the engine before refueling.
- Do not overflow fuel while refueling. Wipe off spilled fuel completely.



When getting on and off the machine, use the steps and handrails to prevent yourself from falling down or off from the machine.

#### Notice

- Be careful not to refuel the tank to a level more than necessary (to the top end of tank). There is a possibility of overflowing because the fuel expands as the outside air temperature rises.
- Be sure to use diesel fuel as fuel, which meets the standard of each country. To achieve a good fuel efficiency and exhaust gas property, the engine of this machine uses the electronically controlled fuel injector. Because this device requires high parts precision and high lubricating ability, when low viscosity fuel with low lubricating ability is used, the durability may decrease significantly.

1. Check the monitor for the fuel level.  
After turning the starter switch to "ON", the fuel level meter is displayed. When the fuel level is low, the pointer points E.
2. Refuel only after stopping the engine.
3. Remove rubber cover (3), if equipped, from the filler port (1) and turn filler cap (2) to open it.
4. Refuel the machine with strainer (4) attached to the filler port (1).  
When dirt is adhered on strainer (4), take out strainer (4), wash it with light oil or clean it by air blowing, and then attach it to the filler port (1) again.  
Fuel tank capacity: 186L(49.1Gal)
5. After refueling, tighten filler cap (2) securely. Attach rubber cover (3) according to the orientation of the cap.

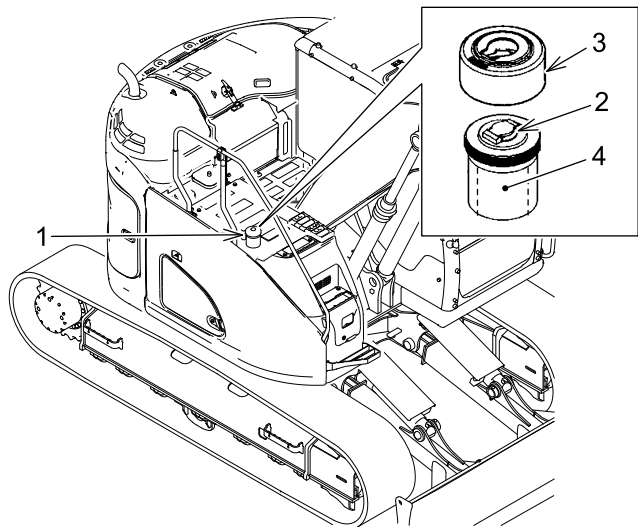



### 3.2.4 DRAINING FUEL PRE-FILTER

#### **WARNING**

To avoid the damage of O-ring, remove foreign matter around the mounting area of drain plug. Damage of O-ring causes leak of fuel, and it causes fire.

The fuel pre-filter is a device which separates water mixed in fuel. When water is accumulated in the fuel pre-filter, drain the water.

1. Use the starter key to open the side door on the right side of the machine and hold it with the stay.
2. Place a drain oil container under drain hose (2).
3. Raise fuel shutoff valve (5) to "Close" position (A).
4. Loosen drain valve (3) and air bleeder plug (4) to drain water accumulated in fuel filter (1) into the container.
5. After draining the water, tighten drain valve (3) and air bleeder plug (4) securely. Check the water drained to the container. If that is contaminated significantly, clean the element and the inside of the case.
6. Lower fuel shutoff valve (5) to "Open" position (B).
7. Remove the support stay and close the side door.

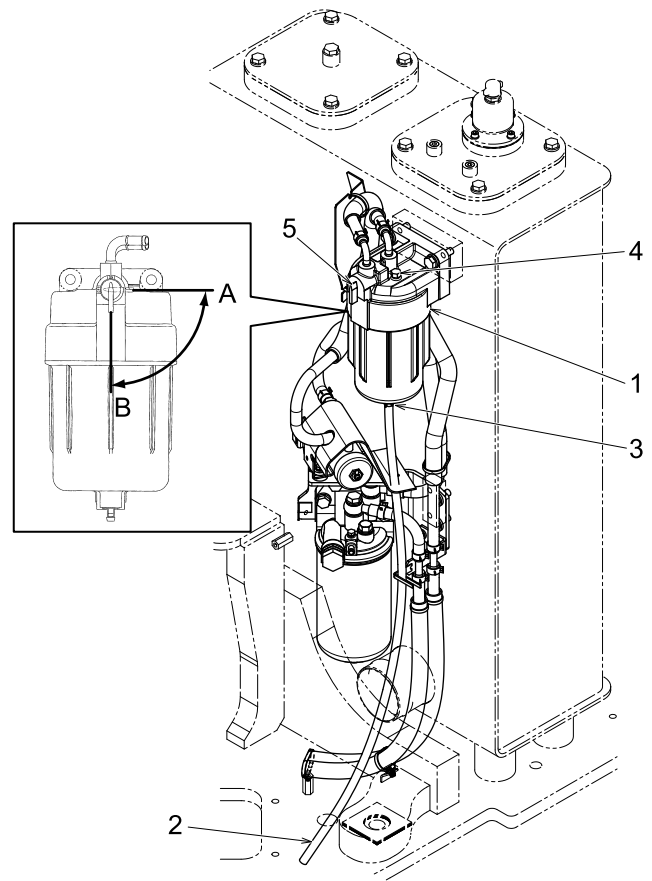

### 3.2.5 CHECKING OIL LEVEL OF HYDRAULIC OIL TANK



#### **WARNING** PRESSURE WITHIN HYDRAULIC OIL TANK

The inside of the hydraulic tank is dangerous because it is high temperature and pressurized.

Before removing the filler port plug (2), stop the engine, remove breather head cap (1), and then press the valve to release the pressure in the hydraulic oil tank.

#### **Notice**

For refilling procedures of the hydraulic oil, see "5000 HOUR INSPECTION & MAINTENANCE PROCEDURES" in Chapter 4.

The hydraulic oil tank is on the right side.

1. Move the machine to a level and firm place.

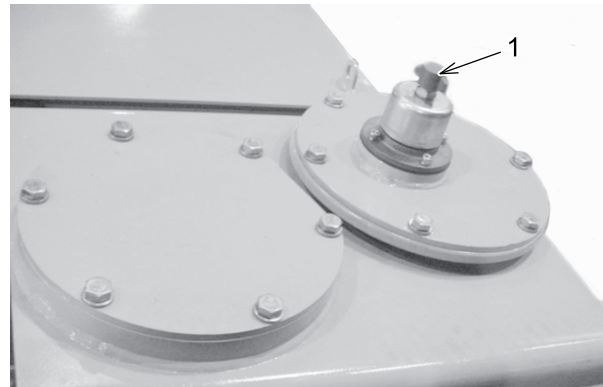

2. Retract the arm cylinder and bucket cylinder, and place the bucket and dozer (when installed) on the ground.

3. Stop the engine and move the pilot control shut-off lever to the "LOCKED" position.

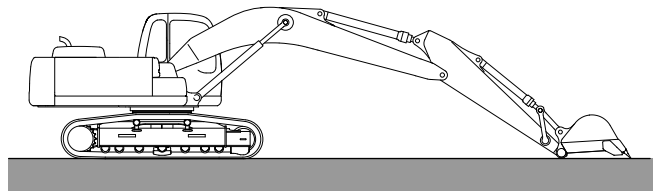

4. Check the oil level through sight level gauge (G) provided on the side of the hydraulic oil tank. If the reading falls within the range of "H" to "L", the oil level is normal.

The oil level varies depending on the oil temperature. Use the following rough standard at inspection.

- Before operation: Near the "L" level (oil temp. 10 to 30 degrees C (50 to 86 degrees F))
- During normal operation: Near the "H" level (oil temp. 50 to 80 degrees C (122 to 176 degrees F))

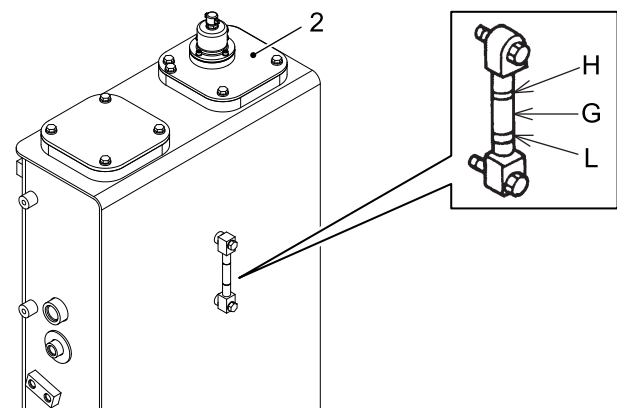

#### **Notice**

Do not supply oil to the "H" level or more.

If the hydraulic oil tank becomes full, it can cause damages to the tank and the components and spray of the hydraulic oil.

### 3.2.6 CHECKING FAN BELT AND AIR CONDITIONING COMPRESSOR BELT



#### INSPECTING AND MAINTAINING THE BELT

Be sure to stop the engine before inspection and maintenance of the engine.

Inspecting and maintaining the running engine may cause severe injury by being caught in the rotating parts, such as the fan and the belt.



Replace the belt with a new one if cracking or breakage is found on the belt by the inspection, slip occurs excessively, or the belt cannot be adjusted to within the adjustment range. Keep the belt away from oils. The service life may be shortened if it slips by oil.

#### Notice

- When the belt is replaced by a new one, run engine at idle for 3 to 5 minutes and recheck and or adjust tension as necessary.
- After running the engine for about 2 hours, a new belt obtains a complete initial elongation.
- When replacing a set of two belts, be sure to replace both two with new ones.

The engine of this machine is equipped with the alternator, the fan, and air conditioning compressor belts. Check the belts for wear and damage, and also for tension, and adjust them properly in order to maintain the maximum engine performance and the service life.

#### Notice

For adjustment procedures for each belt, see "ADJUSTING FAN BELT AND AIR CONDITIONING COMPRESSOR BELT" in Chapter 4.

- To check the belt tension, press on the center of the belt with the compression gauge. If the deflection falls within the range shown in the following table, it is normal.

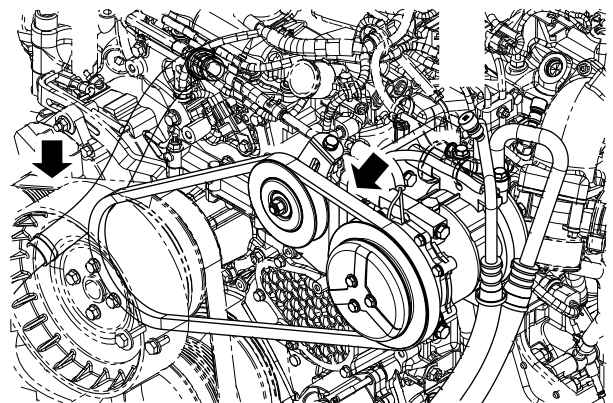

Belt	New Belt Tension mm (inch)	At Inspection mm (inch)	Pushing Force N (lbf)
Fan alternator	4.2 to 5(0.17 to 0.20)	6.6 to 7.4(0.26 to 0.29)	98(22)
Air conditioning compressor belt	2.3(0.09)	2.3(0.09)	<ul style="list-style-type: none"> <li>• 25 to 31 (5.6 to 7.0) *New Belt Tension</li> <li>• 12 to 15 (2.7 to 3.4) *At Inspection</li> </ul>

### 3.2.7 CHECKING RADIATOR, OIL COOLER AND FILTER

1. Using starter key, unlock side door on left side of counterweight, and open it.
2. By visual check, check mud, dust and leaves which contaminate filters (1).
3. When filter is contaminated heavily, refer to "250 HOUR (3-MONTH) INSPECTION MAINTENANCE PROCEDURE" for Inspection and maintenance.

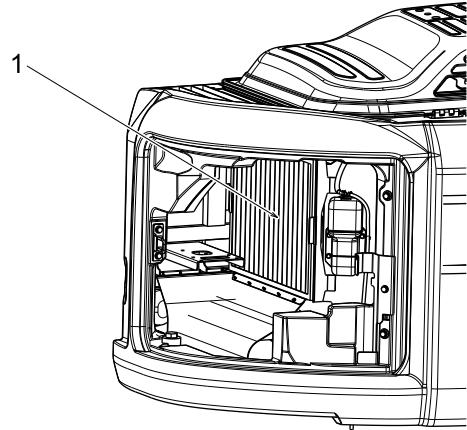

### 3.2.8 CHECKING DEF/ADBLUE LEVEL AND REFILLING

#### **CAUTION**

- Use DEF/AdBlue which meets ISO 22241-1 or JIS K2247-1.
- Do not fill the DEF/AdBlue tank with diesel fuel or water.
- Comply with the precautions specified by the manufacturer when handling DEF/AdBlue.
- For handling of a long term stored DEF/AdBlue, see "PRECAUTIONS FOR LONG-TERM STORAGE" in Chapter 3.

#### **Notice**

- If the pointer of the level gauge on the monitor points the yellow or red range, immediately supply DEF/AdBlue until the pointer points the place higher than the yellow range. DEF/AdBlue shortage restricts the engine output.
- When refilling DEF/AdBlue with the automatic nozzle, sometimes the refilling automatically stops before the water level reaches the F line. In this case, add DEF/AdBlue until the water level reaches the F line.

1. Check the monitor for the level of DEF/AdBlue.  
After turning the starter switch ON, level gauge (1) is displayed on the meter.  
The amount of DEF/AdBlue is displayed with the pointer. When the DEF/AdBlue level becomes low, the pointer points the E point.

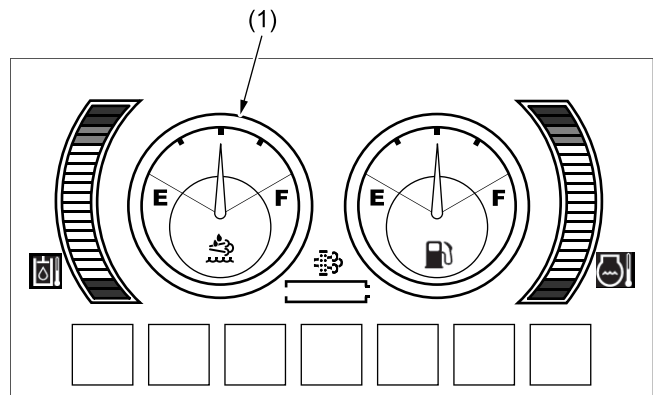

2. Set the machine to the parking position.
3. Stop the engine.
4. Open the right front panel.
5. Turn inlet port cap (2) to open it.  
When dirt is adhered on strainer (3) of the inlet port take out strainer (3), wash it with water, dry it completely, and then attach it to the inlet port again.
6. Refill DEF/AdBlue from the inlet port. Refill it until the level reaches the line F, while checking level gauge (4) on the left side of the tank.  
Full capacity  
20.7L(5.5Gal):  
Applicable No.: YY09045001-YY09046176  
Applicable No.: LH04006001-LH04006031  
26L(6.9Gal):  
Applicable No.: YY09046177-  
Applicable No.: LH04006032-
7. After refilling DEF/AdBlue, tighten cap (2) securely.

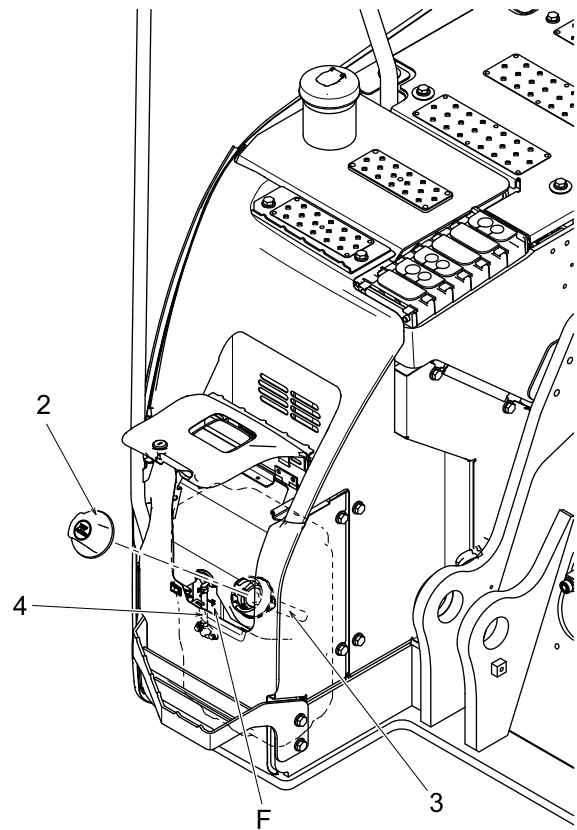

### 3.2.9 ADJUSTMENT OF OPERATOR'S SEAT



#### ABOUT ADJUSTMENT OF OPERATOR'S SEAT

- Adjust the operator's seat before the operation or when the operator changes.
- When adjusting the operator's seat, pay attention to hands in order not to be caught between the handle and the seat stand.

#### Notice

For adjusting procedures of operator's seat, see "HANDLING OF OPERATOR'S SEAT" in Chapter 2.

Adjust the operator's seat in a way so that the operator can operate the control levers, pedals and switches freely, with his/her back contacting with the backrest of the operator's seat.



### 3.2.10 ADJUSTMENT OF MIRRORS

---



#### **WARNING** ABOUT ADJUSTMENT OF MIRRORS

Be sure to adjust the mirrors before operation.

When the mirrors are poorly adjusted, visibility cannot be ensured and it could cause severe injury.

---



Use genuine mirrors only.

When the mirrors are attached to a non-specified place, such as the handrail of the cab entrance, the strength of handrail may be decreased and it may cause damage or falling off of the mirror.

---

Adjust cab left mirror in a way so that the blind spot can be minimized when seeing it from the operator's seat.

- (1) Mirror
- (2) Seat
- (3) Monitor

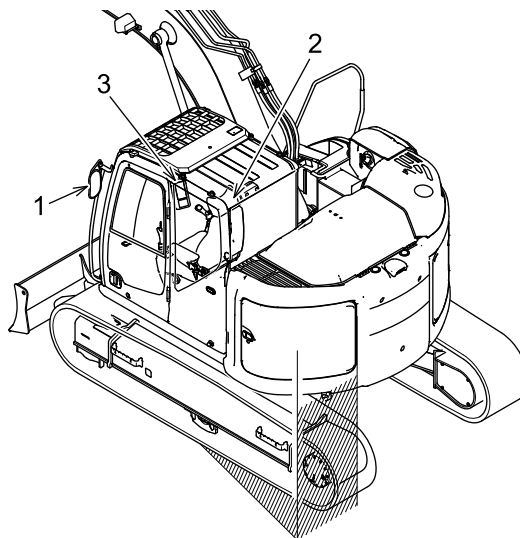

#### VISIBILITY MAP

- The following visibility map is a rough standard of areas (hatched areas) where the operator cannot see both directly and indirectly (through the mirrors and the cameras). The operator can use this map as a reference to improve field rules or enhance visibility by adding an auxiliary device.
  - This machine complies with the visibility requirements stipulated in EN474-1.
  - This map is not the same as the visibility requirements stipulated in EN474-1.
  - This map was made according to the standard specification. Be cautious that the map may change according to the machine specification.
- 

#### **Note**

This map is a rough standard at the ground surface within the radius of 12 m, centering the operator reference point (680 mm above and 20 mm forward from Seat Index Point) from near areas of the machine.

---

Direct and indirect visibilities (from mirrors and two cameras)

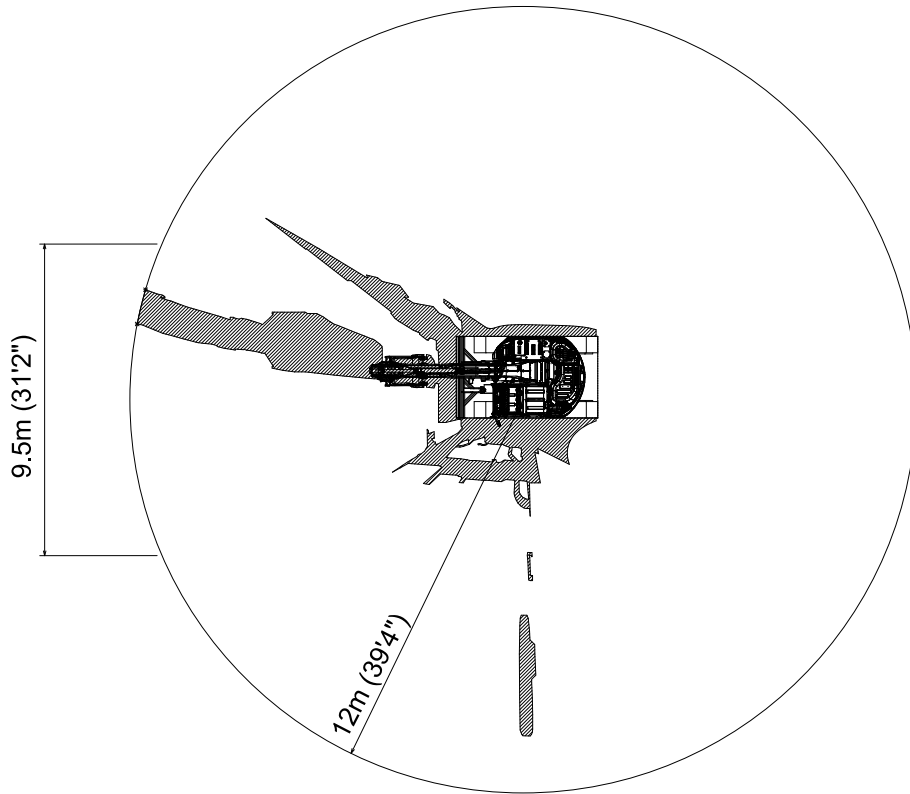

Hatched area: blind spot

Direct and indirect visibilities (from mirrors, and in synthetic view of three cameras)

If the object is placed in the area that the views from different cameras are overlapped, sometimes it is displayed in double images.

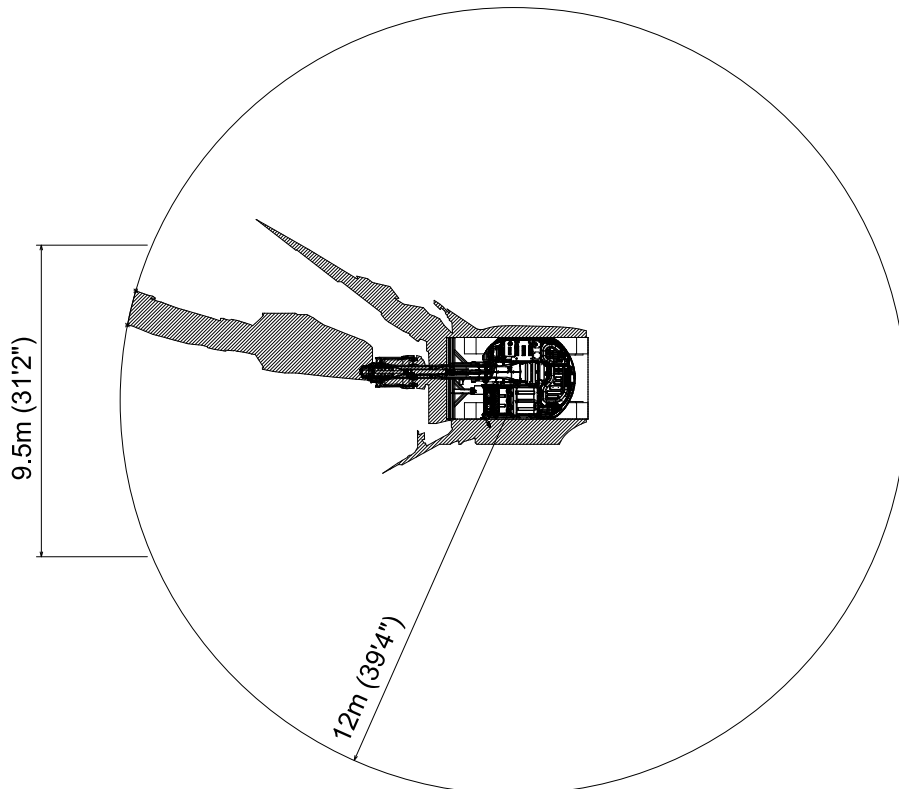

Hatched area: blind spot

### [3. MACHINE OPERATION]

#### MIRROR A (CAB LEFT SIDE)

Adjust the mirror in the way that a person (or the object of 1.2 m (3'11") high and 30 cm (11.8") in diameter) who stands on the left rear end of the machine can be identified by the operator in the operator's seat.

- Install the mirror to the position shown in the figure.
- Install the mirror in the way not to come in contact with stay (1) of the mirror.
- If the movement of the mirror is not smooth, loosen nut (2) of the mirror to adjust it.  
Tightening torque of nut (2)  
M10: 18.6 to 25.5N·m (13.7 to 18.8 lbf·ft)
- Adjust the mirror to reflect the machine side face.

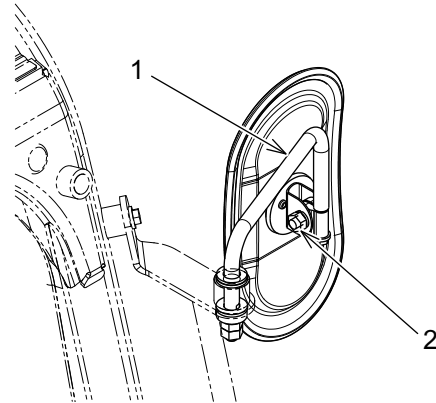

#### SIDE CAMERA (RIGHT SIDE)

Blind spot range

L1: 348mm(13.7")

L2: 919mm(36.2")

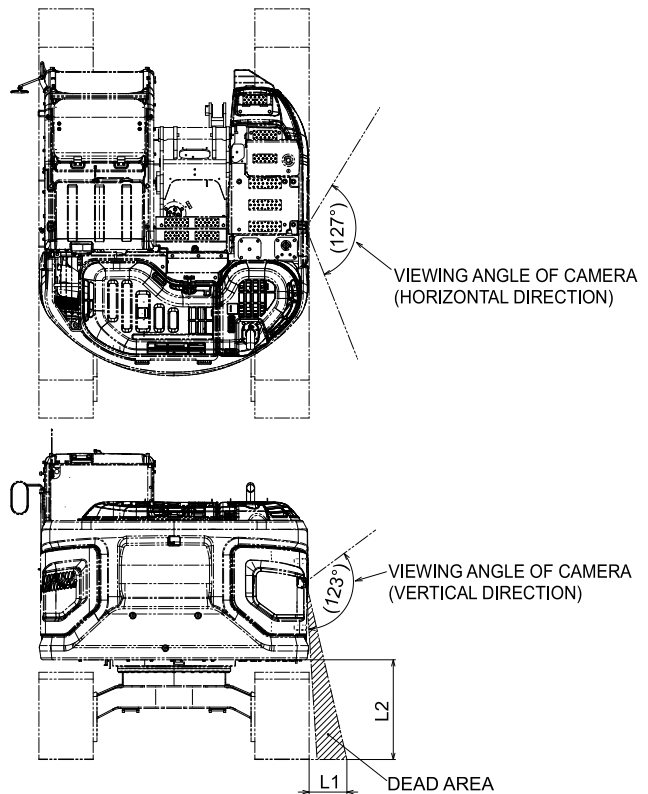



CAMERA (MACHINE LEFT SIDE)

Blind spot range  
 L1: 730mm(28.7")  
 L2: 919mm(36.2")

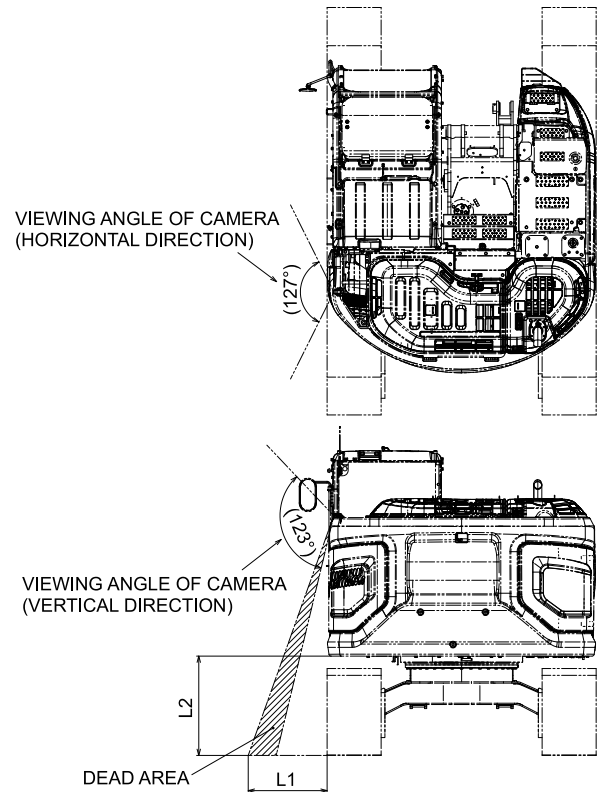

CAMERA (MACHINE REAR SIDE)

Blind spot range  
 L1: 339mm(13.3")  
 L2: 919mm(36.2")

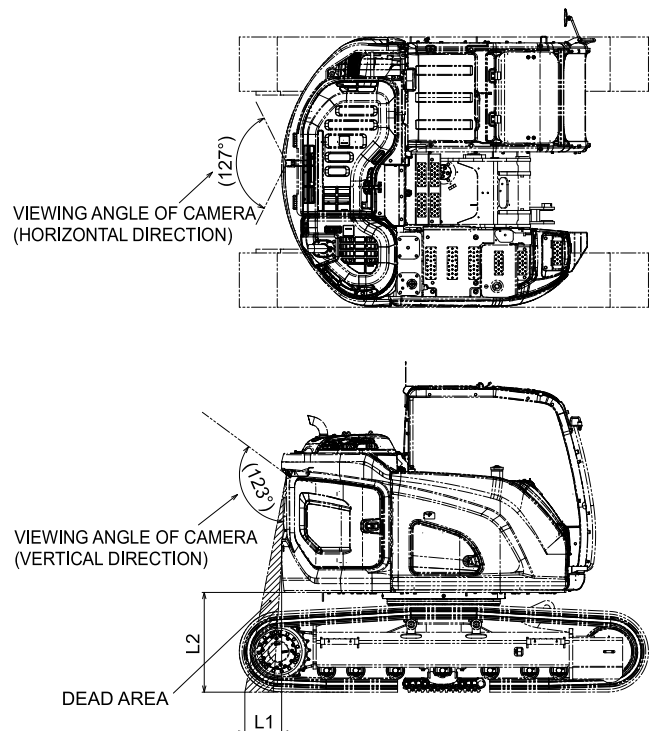

### 3.2.11 CHECKING DISPLAY OF MONITOR

Before starting the engine, check the display status of the monitor according to the following procedure.

---



When the warning is displayed on the monitor, ask your KOBELCO authorized dealer for inspection.

---

1. Make sure the pilot control lock lever is in the "LOCKED" position.
2. Make sure all control levers are in the "NEUTRAL" position.
3. Turn the key of the starter switch to the "ON" position.
4. Check that no warning is displayed on the monitor.

### 3.2.12 CHECKING WORKING LIGHT

While the starter switch is in the "ON" position, press the working light switch to turn on the working lights on the boom and on the right side of the front. If they do not light, presumably light bulbs are burned out or the electrical wire is broken. Ask your KOBELCO authorized dealer for repair.

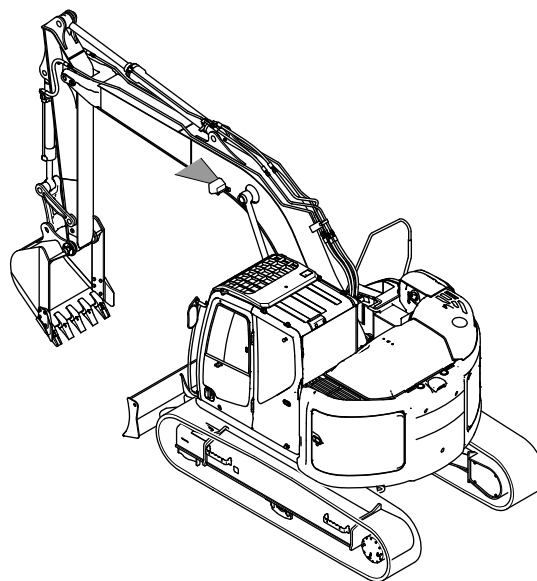

### 3.2.13 CHECKING OF AIR CLEANER INLET

- Check that no mud, leaves, and snow, etc. are accumulated around the air cleaner inlet.
- When it is covered with snow, remove it.
- When washing the machine with high-pressure water for cleaning, be careful not to let the water enter the air cleaner inlet.

## 3.3 STARTING ENGINE



### WHEN STARTING ENGINE

After making sure that no one is near the machine and no obstruction is left around the machine, sound horn and start the engine.

#### Notice

- Do not hold the starter key switch in the START position for more than 15 seconds. If the engine does not start, return the starter key switch to the OFF position, wait 30 seconds, and then try it again.
- When starting engine, if warning is displayed on the monitor, stop engine immediately and identify the cause, and then repair it if necessary.
- After the auto idling stops, when necessary to restart the engine, start the engine after returning the starter key switch to ACC or OFF once and the throttle potentiometer to the low idling position. But it is impossible to start the engine again until the buzzer stops sounding after the engine stops.

### 3.3.1 START-UP UNDER NORMAL TEMPERATURE CONDITIONS

1. Make sure control lock lever (1) is in the "LOCKED" position.  
A: "LOCKED" position  
B: "UNLOCKED" position
2. Make sure all control levers are set to the "NEUTRAL" positions.

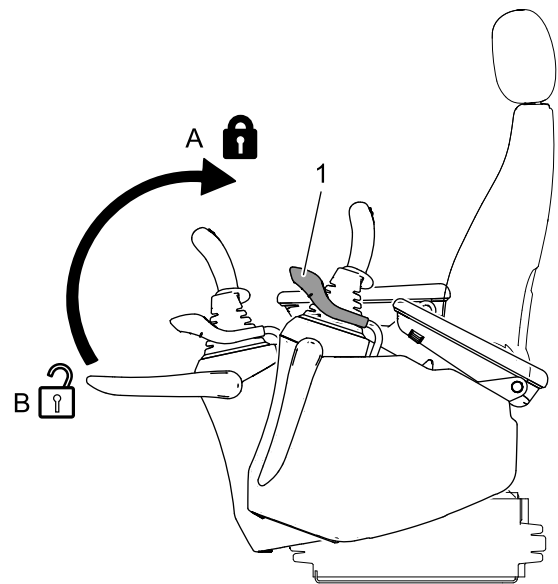

### [3. MACHINE OPERATION]

3. Turn engine throttle (2) to the low idle position.
4. Turn the key of starter switch (3) to the "ON" position and check the operation status of the monitor.
5. Turn the key of starter switch (3) to the "START" position to start the engine.
6. Release key (3) immediately after the engine starts. The starter key will return to the "ON" position by itself.

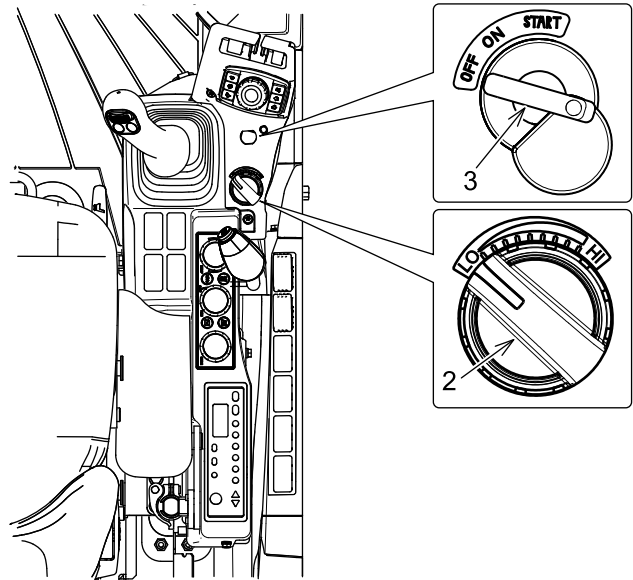

### 3.3.2 START UP IN COLD CONDITIONS

In cold weather, due to increase in oil viscosity and decrease in battery performance, starting the engine may be difficult.

#### Notice

For the engine start up procedures with the automatic warming-up system, see "USER MENU SETTING" in Chapter 2.

1. Make sure the control lock lever (1) is in the "LOCKED" position.

A: "LOCKED" position

B: "UNLOCKED" position

2. Make sure all control levers are set to the "NEUTRAL" positions.

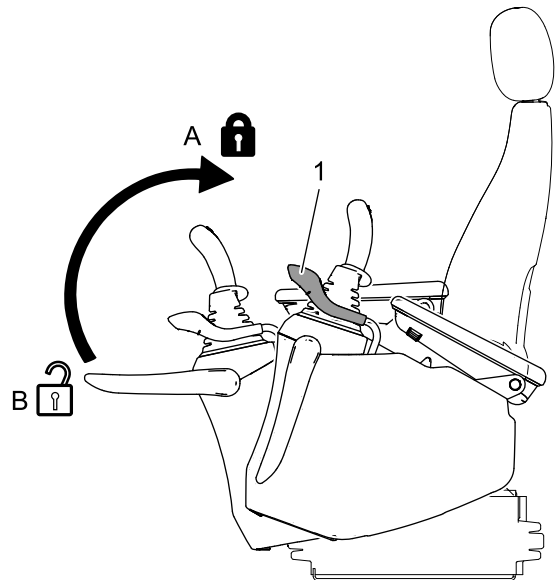

3. Turn engine throttle (2) to the low idle position.
4. Turn the key of starter switch (3) to the "ON" position and hold the position.

When the coolant temperature decreases below 10 degrees C (50 degrees F), the glow plug is preheated automatically by the engine coolant temperature sensing.

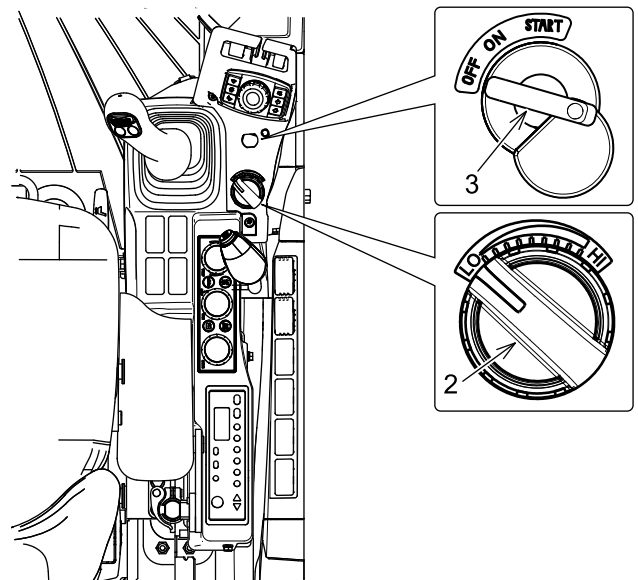

5. Also check the operation of the monitor.
6. After having completed the preheating (within five seconds), turn the key of starter switch (3) to the "START" position to start the engine.
7. Release key (3) immediately after the engine starts. The starter key will return to the "ON" position by itself.



### 3.3.3 USING JUMPER CABLES



#### STARTING ENGINE BY JUMPER CABLES

- Combustible gas (hydrogen gas) is generated in the battery. Do not allow sparks or flames to come in contact with the battery to avoid catching a fire and triggering an explosion.
- Do not allow the normal machine to come in contact with the disabled one to skip negative side cable connection.
- Wear protective glasses and rubber gloves when using jumper cables to start the engine.
- Never allow the positive and negative side clips of the jumper cables to come in contact with each other when connecting the jumper cables.
- Do not mistake positive (+) for negative (-) or vice versa in the jumper cable connection. When the negative jumper cable is finally connected to the upper structure of the disabled machine, it may generate sparks. Connect the jumper cable to a ground surface as far as possible from the battery.
- If the battery electrolyte is frozen, do not attempt to start the engine with another power supply.
- Wrong connection of the jumper cables may cause explosion of the battery.
- The starting system of this machine is 24 volts. Therefore the boost battery voltage in use should be 24 volts. The application of high voltage employed for a welding machine, etc. in engine start may cause damage to the electrical system.



- Use the battery of which the capacity is equivalent to that of the disabled machine for the normal machine.
- Select the jumper cables and clips with a proper size for the battery.
- Check the jumper cables and clips for damage and corrosion.
- Connect the clip securely.
- Check that the control lock lever is in the "LOCKED" position.
- Check that each control lever is returned to the neutral position.
- The starter switches on both the normal and disabled machines must be held in the "OFF" position until the cable connections are completed. Because when the power is connected, it may cause unexpected move of the machines and it is dangerous.

1. For the normal machine, put the attachment on the ground, return all control levers to the neutral position and then set the control lock lever to the "LOCKED" position.
2. Set the starter switch to the "OFF" position for both the normal machine and the disabled machine.
3. Remove the terminal cover of the battery, and connect the jumper cable (red) clip to the positive (+) terminal on the battery of the disabled machine.
4. Connect the jumper cable (red) clip to the positive (+) terminal on the battery of the normal machine.
5. Connect the jumper cable (black) clip to the negative (-) terminal on the battery of the normal machine.
6. Finally, connect the clip of the other end of the negative (-) jumper cable (black) to the upper structure frame of the disabled machine.

Order of connecting the cable ① → ② → ③ → ④  
 Order of removing the cable ④ → ③ → ② → ①

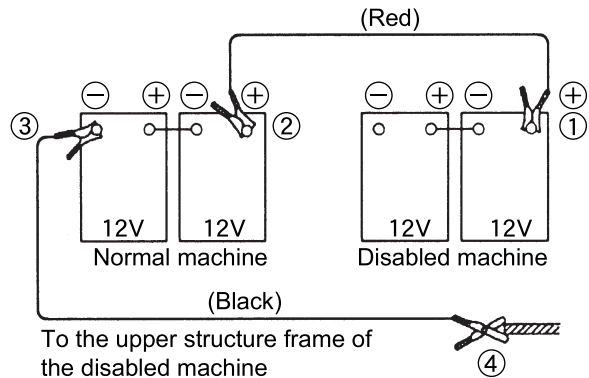

7. Start the engine of the normal machine, and run it for about 10 minutes at high idle.  
The battery of the disabled machine is partially charged.
8. Start the engine of the disabled machine.
9. Soon after the starting of the engine of the disabled machine, immediately remove the jumper cables in the reverse order of the connection.
10. Finally, check and repair the cause of the problem of the start/charging system on the disabled machine.

## 3.4 STOPPING MACHINE ENGINE

1. Place the attachment on the ground before stopping the engine.
2. Pull up the pilot control lock lever to the "LOCKED" position.
3. Turn engine throttle (1) to the low idle position.
4. Turn starter key (2) to the "OFF" position to stop the engine.
5. Remove starter key (2) and store it.

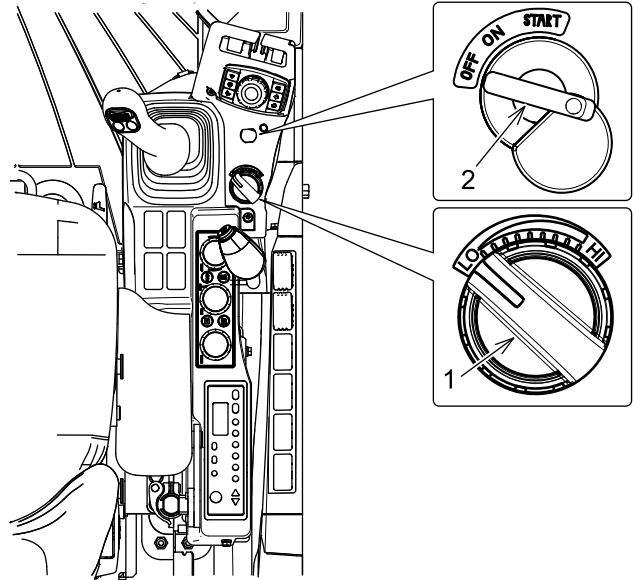



## 3.5 CHECK AFTER STARTING ENGINE

Before operation, be sure to inspect and check the machine after starting the engine. If any failures are found, contact your KOBELCO authorized dealer.

### 3.5.1 CHECK OF PILOT CONTROL LOCK LEVER

Check that the locking function of the pilot control lock lever is proper.

See "PILOT CONTROL LOCK LEVER" in Chapter 2.

1. Move the pilot control lock lever to the "LOCKED" position.
2. Make sure that movement of the attachment, swing and travel, are disabled when the pilot control lock lever is in the "LOCKED" position.

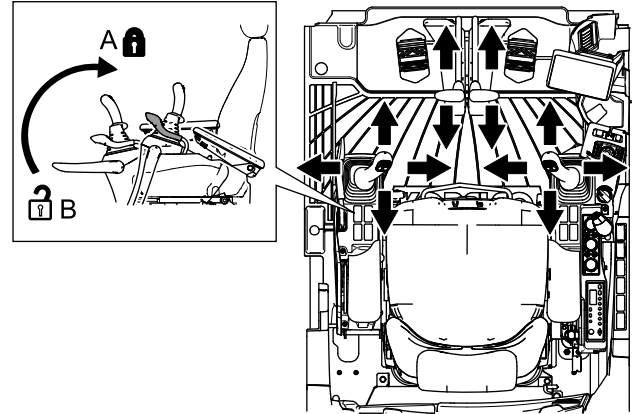

### 3.5.2 CHECK OF ENGINE AND MONITOR

1. Check the engine for oil or water leakage the engine and the area around the engine.
2. Check that no warning is displayed on the monitor and the pointer is at a proper position on engine coolant temperature meter (1) and fuel level meter (2).

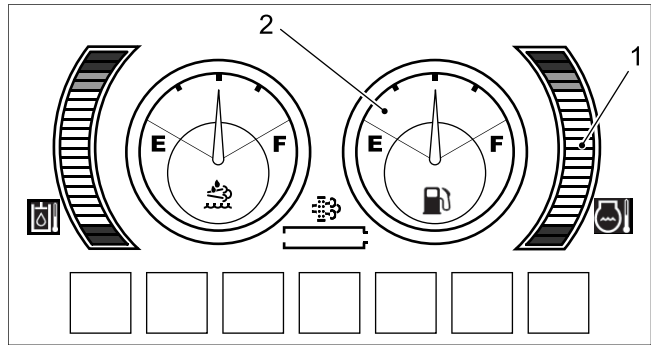

---

**CAUTION**

When the warning is displayed on the monitor, ask your KOBELCO authorized dealer for inspection.

---

3. Check that the exhaust sound, the color of exhaust gas and vibrations of the engine are normal.
- 

**CAUTION**

Inspection with the engine running shall be done by a person other than the operator and the operator shall stay seated during inspection.

---

**Notice**

Color classification for identifying the exhaust gas state (After warming-up at no load)  
Colorless or light blue: Normal (Perfect combustion)  
Black: Abnormal (failure of exhaust gas cleaning device)  
White: Abnormal (failure of exhaust gas cleaning device)  
The smoke may look white in winter due to cold weather.

---

## 3.6 WARMING-UP



### ABOUT WARMING-UP

- When the reading of hydraulic oil temperature meter (3) is in low temperature range (b), rapid operations may cause severe damages to the hydraulic components. Before starting operations, warm-up the hydraulic oil until the reading of hydraulic oil temperature meter (3) rises to normal range (a).
- If the attachment/equipment is operated without enough warming-up operation, the response of the attachment to the control lever is delayed and sometimes it moves in an unexpected manner for the operator. Therefore, be sure to perform the warm-up operation. Especially in cold weather, a sufficient warming-up operation is necessary.

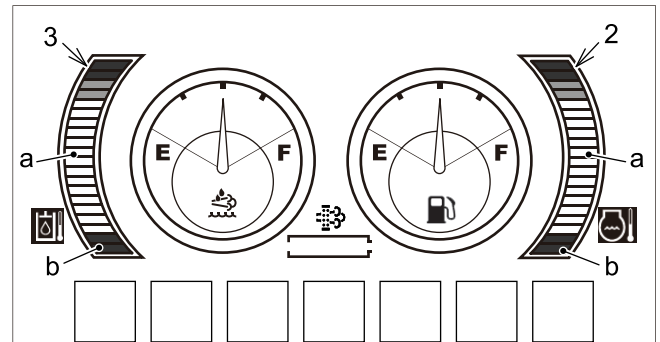

#### Notice

In warming-up the engine, turn auto idling stop function switch OFF.

#### Notice

For the engine start up procedures with the automatic warming-up system, see "USER MENU SETTING" in Chapter 2.

### 3.6.1 ENGINE WARMING-UP

#### Notice

Avoid idling because it may cause poor engine performance and trouble.

### [3. MACHINE OPERATION]

1. Run the engine for about 5 minutes with no load at middle speed by setting engine throttle (1) to the middle between the low idle and the full speed positions.
2. When the reading of engine coolant temperature meter (2) rises to normal range (C), engine warming-up is completed.

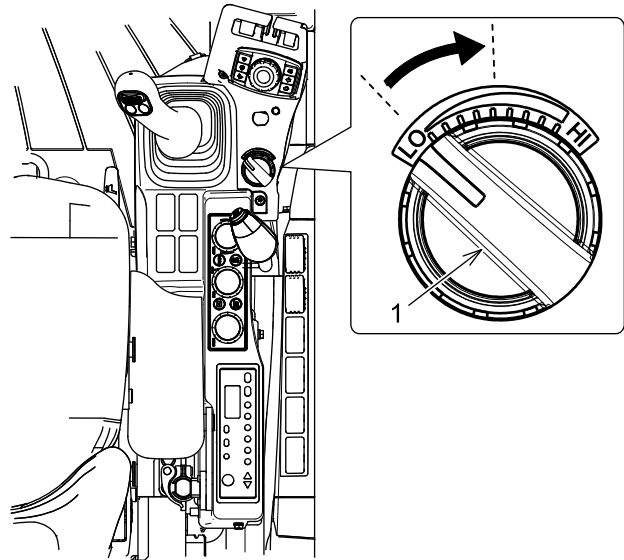

#### 3.6.2 WARMING-UP HYDRAULIC OIL

Perform warming-up of the hydraulic oil after engine warming-up is completed.

1. Push pilot control lock lever (1) down and forward and set it at the "UNLOCKED" position.
2. Raise the boom to the height where the bucket can be operated.

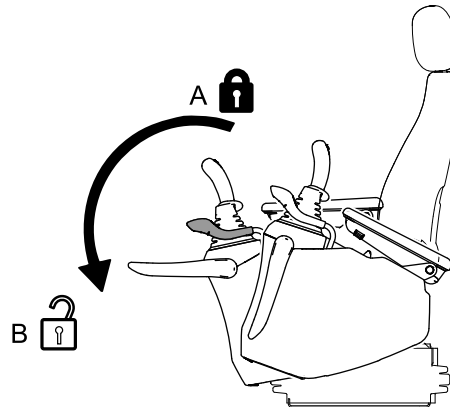

3. Move the right control lever slowly toward bucket digging side (C) to the stroke end position and perform relief operation until the reading of hydraulic oil temperature meter (3) rises to normal range (a).
4. After that, slowly extend and retract each cylinder several times.
5. Also perform swing and travel operations slowly to circulate the warm hydraulic oil in all operation circuits.  
When the reading of hydraulic oil temperature meter (3) is in low temperature range (b), repeat the above-mentioned procedure until it rises to normal range (a).

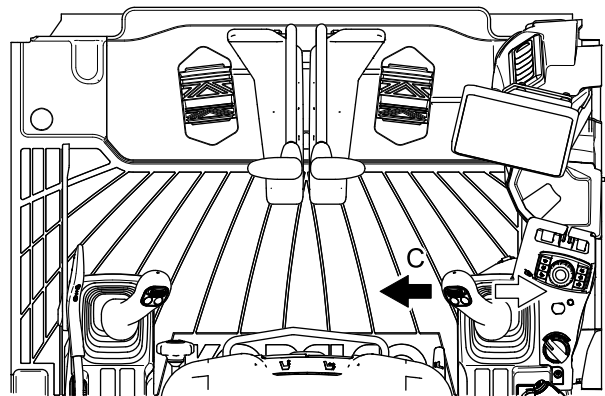

## 3.7 AUTO IDLING STOP FUNCTION

### CAUTION

This machine is equipped with auto idling stop function to reduce the fuel consumption and exhaust gas, due to unnecessary engine idle time.

- When auto idling switch is on, if the engine is running the engine stops after an elapse of the specified time from when the safety lock lever is pulled up.
- After the auto idling stops, when necessary to restart the engine, start the engine after returning the starter key switch to ACC or OFF once and the throttle potentiometer to the low idling position. But it is impossible to start the engine again until the buzzer stops sounding after the engine stops.
- If you would like to perform warming-up of the engine, operate the air conditioner, or use the working light continuously with the pilot control lock lever in the "LOCKED" position, turn the auto idle stop function "OFF". With the auto idle stop function turned "ON", the engine stops, so that the function stops.
- When necessary to leave the operator seat, always turn the starter switch off.
- When the failure warning of "engine coolant temperature" or "coolant level" appears, or auto warming-up is working, the auto idle stop function does not work regardless whether the auto idle stop function turns "ON" or "OFF".
- Do not use auto idling stop mode when lifting.

This switch is usually set to "OFF". When the auto idling stop function is selected, the engine stops automatically after an elapse of the specified time with the control lock lever (1) set to "LOCKED" position (A) during engine operation. This function is effective in saving of fuel and in restraint of exhaust gas by setting auto idling stop function.

- As for the setting of the auto idle stop function, see "Setting of auto idle stop" in Chapter 2.
- The default setting of the interval until engine stop is 60 seconds.  
To change the set interval, contact your KOBELCO authorized dealer.

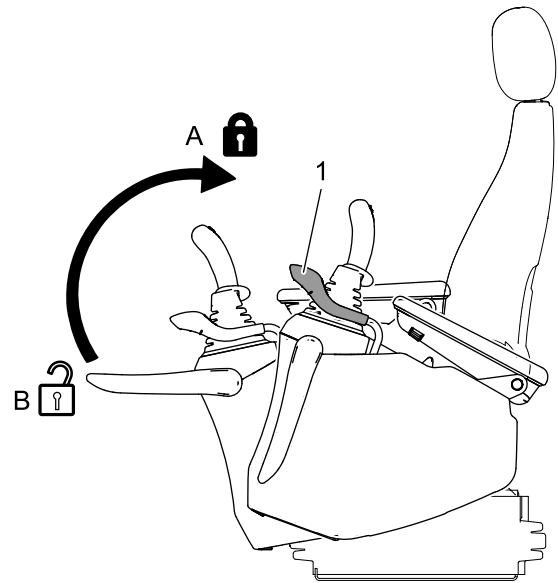

3

### Notice

- After setting control lock lever to "LOCKED" position (A), the engine changes to "DECEL" speed about 4 seconds later.
- Buzzer sounds for 5 seconds before engine stops.

### 3.7.1 RESTART AFTER AUTO IDLE STOP

### CAUTION

When leaving the operator's seat, be sure to set the starter switch to the "OFF" position.

### [3. MACHINE OPERATION]

---

1. Check that the buzzer stops.
2. Turn the engine throttle to the low idle position.
3. Return the key of the starter switch to "ACC" or "OFF" once and then restart the machine.

## 3.8 WORK MODE SELECTION

### Jog dial operation

#### Tilting (a,b,c,d) and rotating (e,f) the jog dial

To move the cursor on the monitor and adjust the values and others.

#### Pushing down (g) the jog dial

- To switch the screen to the selected setting screen.
- To determine the adjusted value and others.

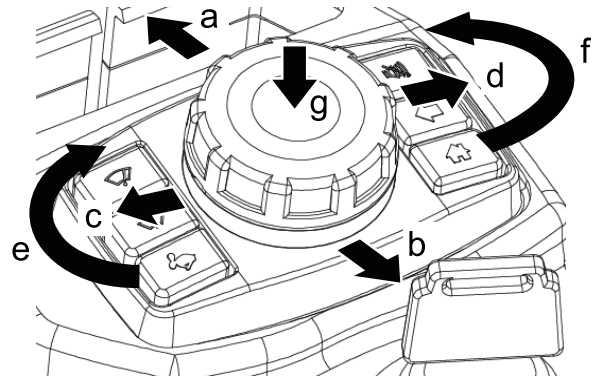

Select a proper work mode from three modes shown below according to the work condition and purpose. Move the cursor to [work mode selection] (8) and push down (g) the jog dial to switch the mode.

#### S mode:

"S mode" is suitable for a standard digging work and loading operations. It provides good fuel consumption and is well-balanced with a workload.

#### ECO mode:

"ECO mode" focuses on reduced fuel consumption operation.

#### H mode:

"H mode" is suitable for a heavy digging work, which provides high speed and gives priority to a workload.









8



Before beginning the work, make sure the selected work mode is correct.

## 3.9 SWITCHING ATTACHMENT MODE

Select an appropriate mode to use according to the attachment installed.

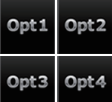
Display	Attachment mode	Summary
	Bucket	This mode needs to be selected for digging work.
	Breaker	This mode needs to be selected when an attachment using a single flow circuit such as a breaker is installed.
	Nibbler (crusher)	This mode needs to be selected when a hydraulic crusher such as a nibbler is installed.
	Rotary grapple	This mode is designed considering the operation such as a grapple.
	Processor	This mode is designed considering the operation such as a processor.
	Thumb bucket	This mode is designed considering the operation such as a thumb bucket.
	Rotary tilt	This mode is designed considering the operation such as a rotary tilt.
	Individual setting	This mode can be customized for an attachment other than those mentioned above.

### CAUTION

- When the attachment mode is inappropriate, select a proper attachment mode.
- Always select the breaker mode when operating a breaker. Working in a mode other than the breaker mode causes damages to the hydraulic components and/or the breaker.
- Be sure to lower the attachment to the ground and ensure safety before switching the attachment mode.

### Notice

- If tuning of operability is needed, contact your KOBELCO authorized dealer.
- When the control lock lever is raised upward to the "LOCKED" position, setting for changing the screen becomes possible.



## 3.10 MACHINE OPERATION

The machine operation procedures described below provide operators with basics which should be learned and understood, thoroughly. You can further improve your operational skill by thoroughly learning the performance and structure of this machine.

### 3.10.1 PRECAUTIONS OF MACHINE OPERATION



#### WHEN OPERATING MACHINE

- When starting the machine, check the safety around the machine and sound the horn before starting the machine.
- Keep the area around the machine clear of people.
- When the control lever is operated during the auto acceleration operation, the engine speed increases abruptly. Operate the control lever carefully.



- The indications on the monitor do not assure the condition of the devices. Daily maintenance should be performed not only by seeing the monitor but also by following the procedures described in this manual.
- When abnormality was detected during operation, stop the machine immediately and take proper measures.
- The machine should not be operated until the failure is repaired. Operating the machine with the failure that has not been repaired may result in a serious accidents.

#### FRONT/REAR AND LEFT/RIGHT OF MACHINE

In this manual, front/rear and left/right are determined by looking the forward direction from the operator's seat with the travel motors at the rear side.

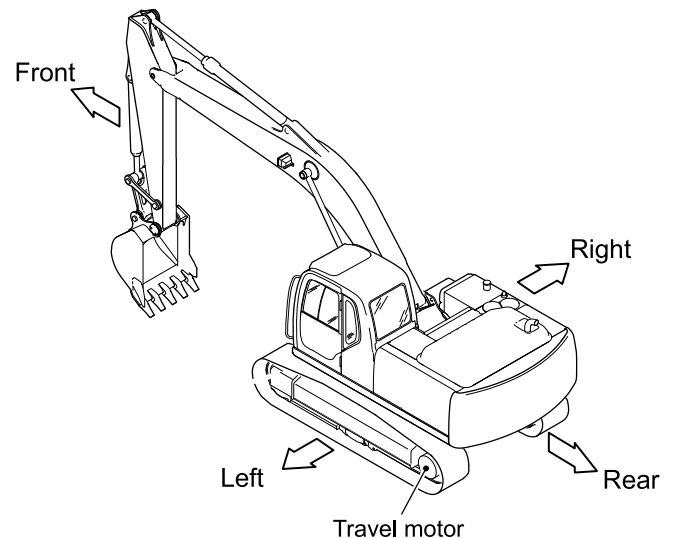

### 3.10.2 TRAVEL PROCEDURES



#### ABOUT TRAVELING

- Confirm the travel motor position before traveling. When the travel motor is positioned at the front side, the machine moves reversely to travel lever operations.  
The normal travel control can be performed when the travel motor is at the rear side of the machine and the front idler is at the front side of the machine.
- Sound the horn to warn the workers in the working site.



#### ABOUT TRAVEL SPEED

During traveling, do not change the travel speed. Also, the travel speed should be set to the LOW (1st) speed when the machine is traveling on a downhill, or being loaded to/unloaded from a trailer. A sudden change of the machine stability could cause personal injury.

Before starting traveling operation move the control lock lever to "UNLOCKED position" and set the bucket at the height of 30 to 40 cm (12 to 16 inch) above the ground.

F: Forward traveling

N: Neutral (Stop)

R: Backward traveling

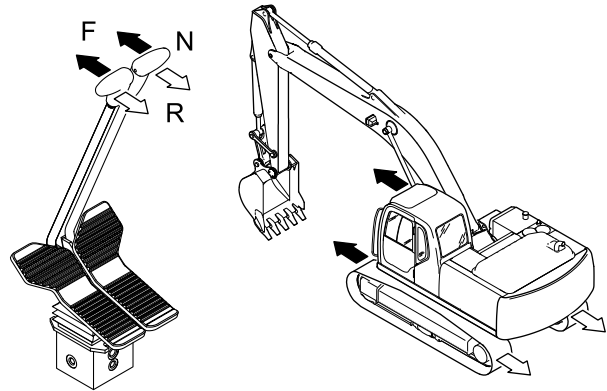

#### Forward/Reverse traveling

- Push (forward) or pull (backward) both the left and right travel levers simultaneously.  
Both the forward and reverse travel speed can be changed by lever displacement.

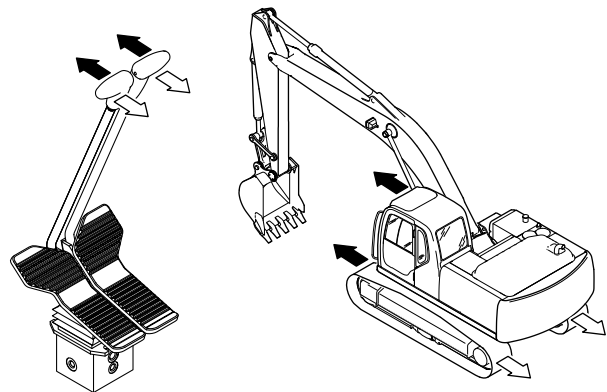

Pivot turn

This operation drives only one crawler to turn the machine.

- Operate one of the two travel levers to make a pivot turn.

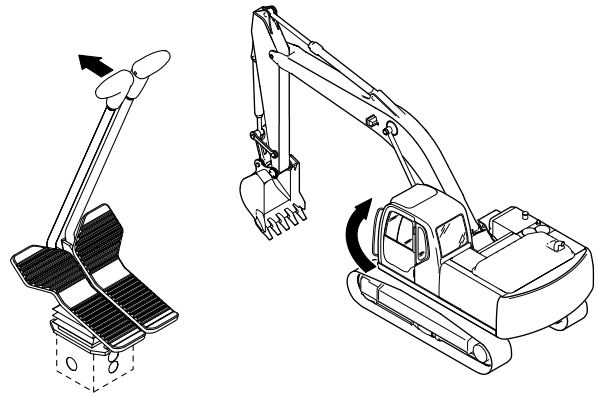

Spin turn

This drives the right and left crawlers in opposite direction each other to turn the machine on the spot.

- Push one of the two travel levers forward and pull the other lever backward simultaneously.

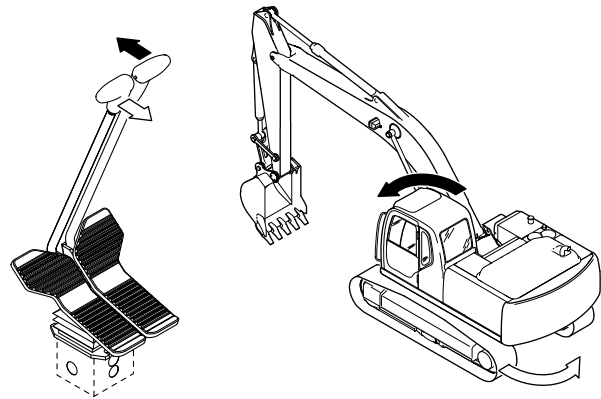

STOP TRAVELING



**WARNING** ABOUT STOP TRAVELING

Do not stop the machine suddenly, but stop it after slow down the speed as much as possible.

- Put both travel levers (1) in the "NEUTRAL (N)" position. The machine stops traveling.

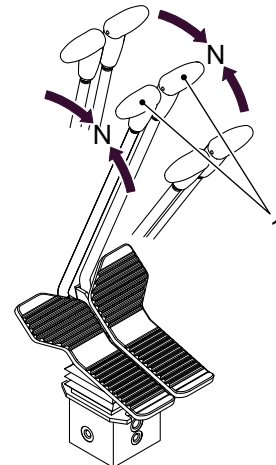

### 3.10.3 TRAVEL SPEED SELECTION



#### ABOUT TRAVEL SPEED

The travel speed should be set to the LOW (1st) speed when the machine is traveling on a downhill, or being loaded to/unloaded from a trailer. A sudden change of the machine stability could cause personal injury.

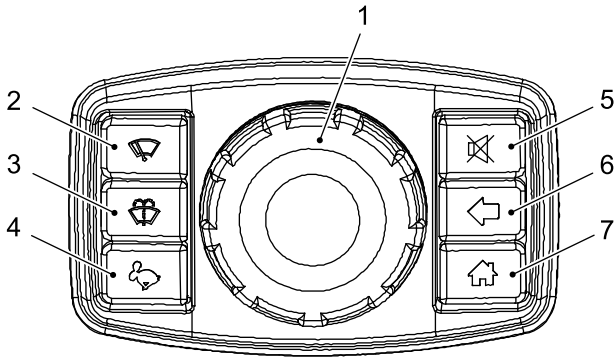

Each time the engine is started, the travel speed is automatically set to the LOW 1st (turtle) speed. Press switch (4) on the control panel and then the travel speed changes to the HIGH (2nd) speed and the icon displayed on the monitor changes to the HIGH (2nd) speed (rabbit).

LOW 1st speed: turtle



Set to LOW 1st speed when moving the machine on the rough or soft ground, slope, or in the narrow place, or when powerful tractive force is required.

HIGH 2nd speed: rabbit



Set to HIGH 2nd speed when moving the machine on a level and firm ground.

#### Notice

The HIGH (2nd) speed is automatically switched to the LOW (1st) speed when the load of traveling becomes high and automatically returned to the HIGH (2nd) speed when the load is lowered.

### 3.10.4 MACHINE OPERATION IN WATER OR ON SOFT GROUND

#### IMPORTANT

Take enough care not to immerse the swing bearing, swing pinion and swivel joint into water or soil. When the machine is sunk to the level of or above the swing bearing in the water or soil, the swing bearing and others may be worn abnormally if it is used without any treatment. Apply grease to the greasing points.

- If the bottom of a river is flat and it flows slowly, the machine can travel in the water up to the depth of the center of upper roller (A).
- When crossing a river, carefully cross the river while checking the condition of the river bottom by the bucket, etc. Never enter the water over the depth of (A).
- On a soft ground, the machine may sink gradually. Pay attention to the travel system and the water depth all the time.
- After traveling in seawater, wash the machine carefully to remove salt.
- On parts soaked in the water for a long time, use a grease gun to apply grease securely, until the old grease comes out from the inside.

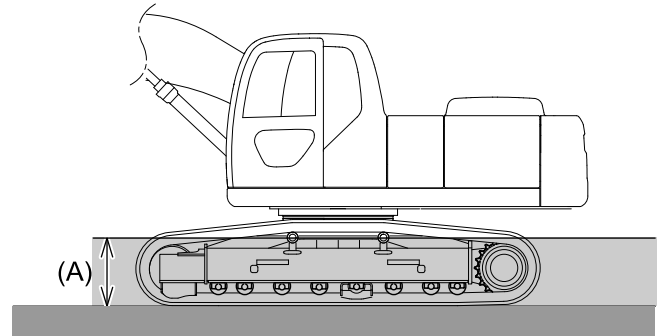

### 3.10.5 GETTING OUT OF SOFT GROUND

Avoid traveling on a soft ground if possible.

Be careful not to get stuck in mud. In case of being stuck in the mud, get out of it using the procedure below.

#### WHEN ONE SIDE OF MACHINE GETS STUCK IN SOFT GROUND

- When one side of the machine gets stuck in the soft ground, push the bottom of the bucket against a plank or others laid on the ground to lift up the stuck shoe, and put logs or lumbers beneath the crawler belt to escape from the soft ground.

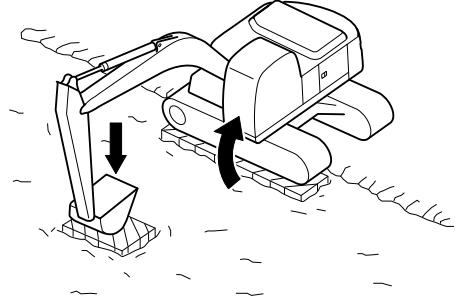

---

**Notice**

When using the boom and arm to lift up the machine, push the bottom of the bucket, not the teeth, against the ground.

---

#### WHEN BOTH SIDES OF MACHINE GET STUCK IN SOFT GROUND

**CAUTION**

Operate the machine at the operator's seat. Keep the area around the machine clear of people.

---

1. When both sides of the crawlers get stuck in the mud and the machine does not move due to slip, put logs or lumber as described above, lower the attachment to the front ground, pull the arm just like digging, push the travel levers forward, and pull out the machine.

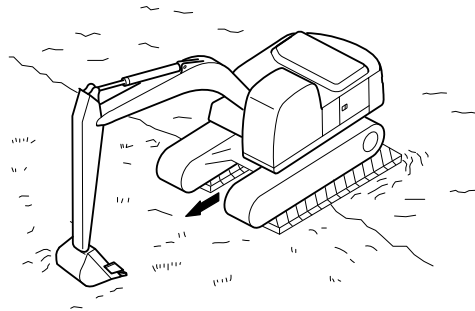

2. If the machine cannot travel due to highly tensed crawlers caused by clogged mud and gravel in the crawlers after traveling on the soft ground, lift each crawler off the ground by pushing the boom and arm against the ground and shake the mud or gravel off the crawler, and then get out of the soft ground. Gravel, or mud clogged in the crawler can be shaken off by lifting the crawler up and moving it forward and backward.

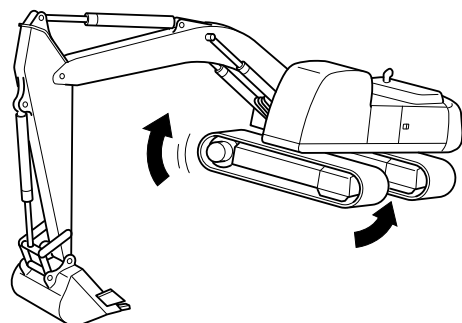

### 3.10.6 SWING AND ATTACHMENT/EQUIPMENT OPERATIONS

The following is the explanation of operation of the standard attachment/equipment. As to the machine equipped with a special attachment, read the operation manual of the special attachment, too.

The operation is explained according to the ISO pattern. As for the other operation patterns, see "MULTI-CONTROL VALVE" in "MACHINE FAMILIARIZATION" or "OPTIONAL EQUIPMENT".



#### ABOUT THE USE OF THIS MACHINE

To operate this machine, fully read the safety precautions of this manual and understand them thoroughly.



#### INTERFERENCE BY FRONT ATTACHMENT

Check clearance between the front attachment and the operator's station and other parts of the machine before starting operation because a certain kinds of front attachment and combination of the options installed on the base machine may cause the front attachment to interfere with the operator's station or other parts of the machine.

#### BOOM OPERATION

To operate the boom, move the right control lever forward and backward. Speed of the boom is controlled by the displacement of the control lever.

- A: Pull the right control lever backward to move the boom up.
- B: Push the right control lever forward to move the boom down.
- Return the right control lever to the neutral (center) position to stop the boom.

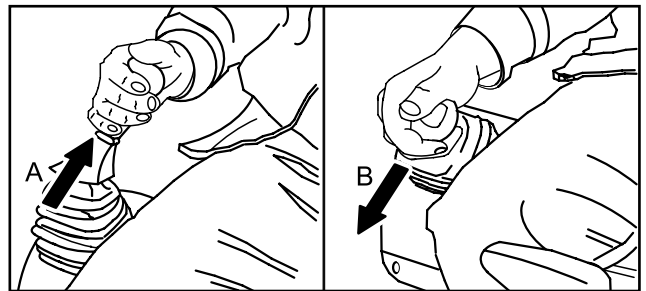

3

#### ARM OPERATION

To operate the arm, move the left control lever forward and backward. Speed of the arm is controlled by the displacement of the control lever.

- A: Pull the left control lever backward to move the arm closer to the cab (Arm in).
- B: Push the left control lever forward to move the arm forward and away from the cab (Arm out).
- Return the left control lever to the neutral (center) position to stop the arm.

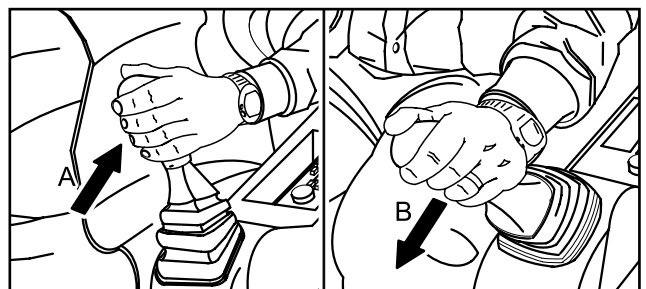

### [3. MACHINE OPERATION]

---

#### BUCKET OPERATION

To operate the bucket, move the right control lever left and right. Speed of the bucket is controlled by the displacement of the control lever.

- A: Move the right control lever left to move the bucket to the digging side.
- B: Move the right control lever right to move the bucket to the dumping side.
- Return the right control lever to the neutral (center) position to stop the bucket.

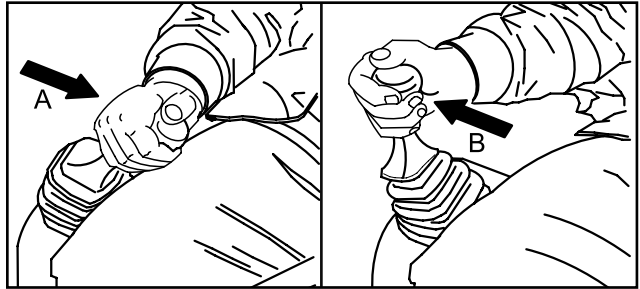

#### SWING OPERATION

---



#### PRECAUTIONS TO PREVENT DANGER IN SWINGING

Make sure that the swing area and the surroundings are clear of obstacles and people before beginning operation. Sound the horn or send signals to warn people before starting to operate the machine.

---

To perform the swing operation, move the left control lever left and right. Speed of the swinging is controlled by the displacement of the control lever.

- A: Move the left control lever left to swing the machine left.
- B: Move the left control lever right to swing the machine right.
- Return the left control lever to the neutral (center) position to stop the swinging.

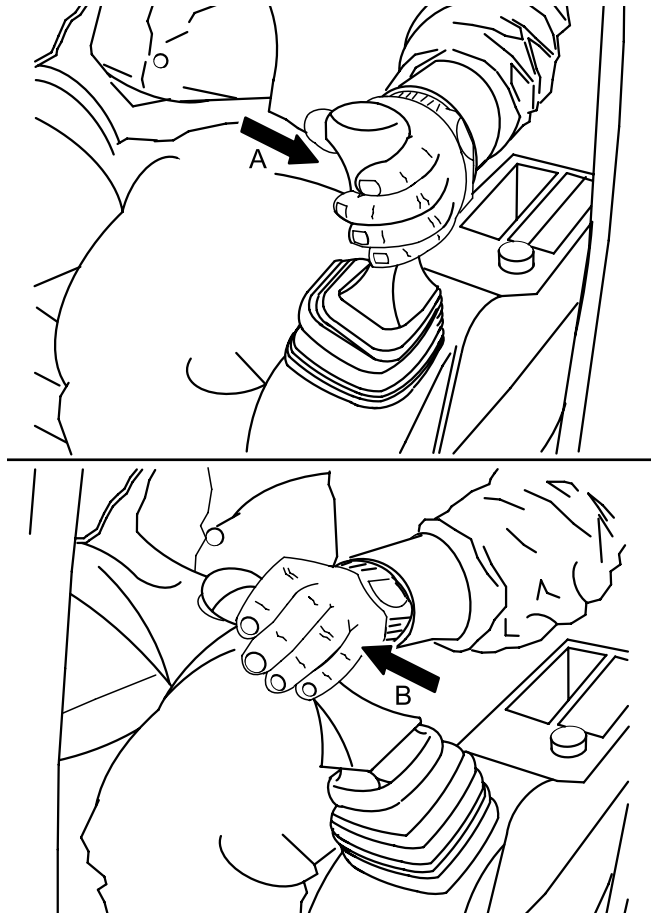



## 3.11 WORK PROCEDURES OF MACHINE

### 3.11.1 DIGGING WORK

For digging work, mainly the arm crowding force is used, and the bucket scooping force may be used if necessary.

- When a strong digging force is required, dig slowly while keeping angle (C) between the boom and the arm at approximately 90 to 110 degrees. When lowering the boom, avoid rapid operations. Especially, urgent stop during boom "DOWN" has a great impact on the machine, resulting in adverse effects on parts.
- Point the bucket tooth tips to digging direction (A) as much as possible, and dig with the bucket positioned at shallow depth (B) by operating the arm and the bucket. This will reduce the digging resistance and damage to the tooth tips.
- If soil does not fall out easily, set the bucket in the bucket out position and move the bucket a few times by the control lever. Never extend and retract the bucket cylinder repeatedly with the boom cylinder and the arm cylinder fully extended or retracted to fall out the soil.
- When digging a wide trench, dig both sides of it first and dig the center last. To improve the efficiency, attach a bucket suitable for trenching and place the crawlers parallel (C) to the trench to dig.

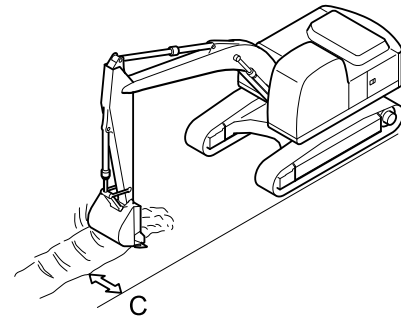
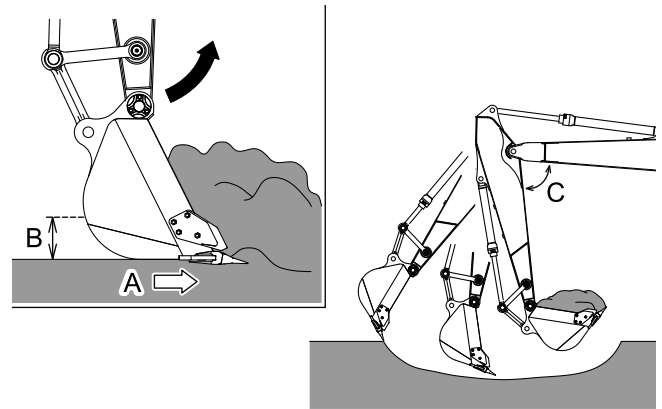

### 3.11.2 LOADING WORK

- Before performing loading and unloading, set a dump truck on a place where the dump truck can be easily seen from the operator with the smaller swing angle.

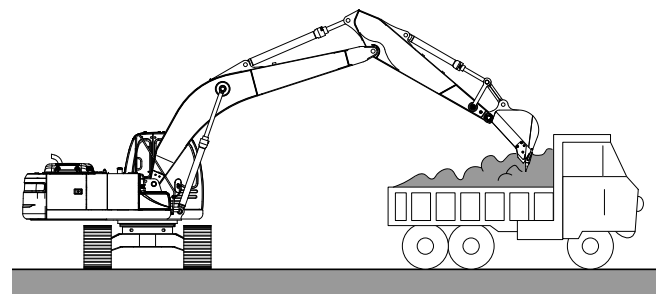

### 3.11.3 GROUND LEVELING WORK

1. For backfilling and leveling work after digging, use the dozer.
2. Scrape the embankment from the top surface. If the load on the machine is too much, adjust the dozer height by using the dozer control lever to move the dozer up and down.

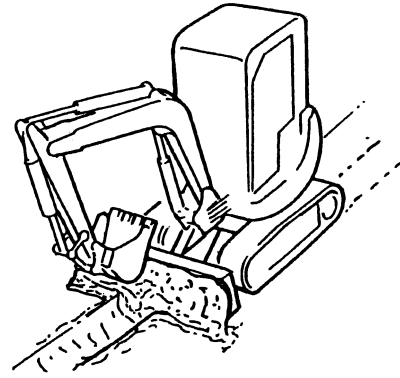

## 3.12 ALWAYS PARK MACHINE PROPERLY

1. Travel machine to a safe location on firm, level ground.
2. Lower the attachment to the ground.  
If equipped with a dozer blade, lower it to the ground.
3. Set the auto acceleration switch to the "OFF" position.

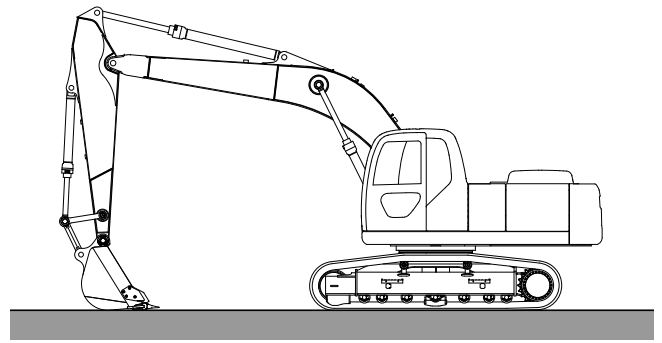

4. Pull the control lock lever(1) to the locked(up) position(A).  
If not locked, accidental or unintended contact with the control levers, pedals and other control devices may result in unexpected and unintended machine movement.
5. Turn engine throttle to the low idle position.
6. Turn the starter switch to the "OFF" position and remove the key.  
Close and lock the windows and the cab door.  
Check the windows, doors and all other machine access covers are locked and secured.

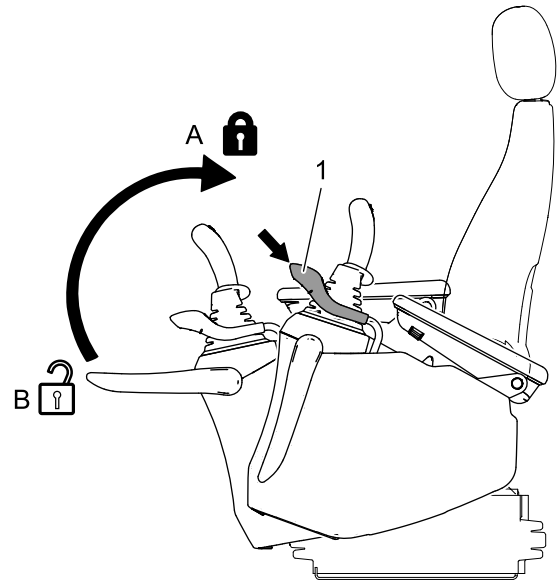

3

### 3.12.1 PARKING MACHINE ON SLOPE

If the machine must be parked on a slope.

1. The undercarriage and the upper structure and the attachment /equipment must face downhill.
2. Lower the attachment into the ground. If equipped with a bucket, wedge the bucket into the ground.  
If equipped with a dozer blade, lower it to the ground.
3. Set the auto acceleration switch to the "OFF" position.

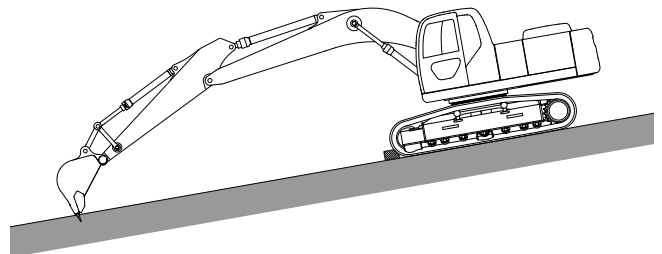

### [3. MACHINE OPERATION]

---

4. Pull the control lock lever(1) to the locked(up) position(A).  
If not locked, accidental or unintended contact with the control levers, pedals and other control devices may result in unexpected and unintended machine movement.
5. Turn engine throttle to the low idle position.
6. Turn the starter switch to the "OFF" position and remove the key.  
Close and lock the windows and the cab door.  
Check the windows, doors and all other machine access covers are locked and secure.
7. Block the tracks in the front and the rear.

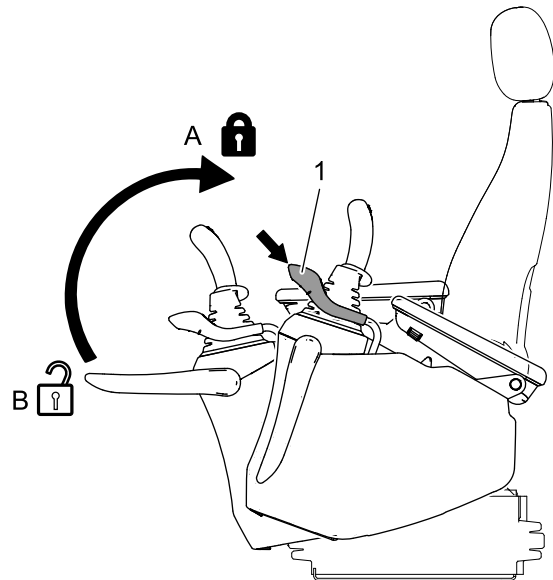

## 3.13 INSPECTION AND CHECK AFTER OPERATION

Check the engine coolant temperature, engine oil pressure and fuel level on the monitor.

- If there is the engine coolant temperature or the engine oil pressure warning display, move the machine to a safe place and stop the engine immediately. Then repair the machine according to "INSPECTION AND MAINTENANCE CHART" in Chapter 4.
- Check oil and water leakage, the attachment/equipment, the exterior parts, and the travel system components. If leakage or damage is found, repair it immediately according to "INSPECTION AND MAINTENANCE CHART" in Chapter 4.
- Refuel the tank to the maximum. Refuel the tank to the maximum after finishing work for a day. Be careful not to refuel the tank to a level more than necessary (to the top end the tank). There is a possibility of overflowing because the fuel expands as the outside air temperature rises.
- Clean all slippery substances such as grease, oil, hydraulic oil, mud, and others attached to the steps, handrails, crawlers, ladders, and platforms.

## 3.14 MACHINE OPERATION IN ADVERSE CONDITIONS

### 3.14.1 OPERATION IN COLD CONDITION



When the ambient temperature is low, starting the engine may be difficult due to decrease of oil liquidity, and the radiator may be damaged due to coolant freezing.

#### FUEL/OIL

Use good low-viscosity fuel/oil for each device. For the optimum viscosity, see "LUBRICANT, FUEL & COOLANT SPECIFICATIONS" in Chapter 4.

#### COOLANT

When operating or storing the machine in cold climates, the additive rate of the cooling system should match the expected minimum outdoor temperature.

If the coolant is frozen, it may cause damage to the radiator, cylinder block and cylinder head. When being shipped from the factory, "Long Life Coolant" is used to prevent rust and freezing of the cooling system.

When operating or storing the machine in extreme cold, check the coolant frequently to keep an appropriate concentration. For the concentration of coolant, see "LUBRICANT, FUEL & COOLANT SPECIFICATIONS" in Chapter 4.

#### BATTERY

When the ambient temperature is low, the battery capacity may decrease and the battery electrolyte may freeze. Charge the battery full earlier than the specified interval and pay full attention to thermal insulation by covering the battery.

When leaving the machine outdoors overnight, it is recommended to remove the battery and store it in a warm room.

Measure the specific gravity of battery electrolyte after its temperature becomes almost the same as the outdoor temperature, instead of immediately after operation. The charging rate can be calculated roughly by measuring the specific gravity and using the table below.

#### Specific Gravity of Battery Electrolyte

Charging rate	Battery electrolyte temperature		
	-20 degrees C	0 degrees C	20 degrees C
100%	1.31	1.29	1.28
90%	1.29	1.28	1.26
80%	1.28	1.26	1.25
75%	1.27	1.25	1.24

#### AFTER OPERATION

To prevent malfunctions of the travel system components due to freezing of mud and water stuck to them, follow the precautions below.

- Remove mud and water stuck to the machine sufficiently. Especially, be sure to drain off the water from the travel system, and then park the machine on a dry and firm ground to prevent the travel system from freezing.
- Wipe the cylinder rod completely. If frozen mud or water is stuck to the cylinder rod surfaces, the seal may be damaged when retracting the cylinder. Retract each cylinder to the minimum size to minimize the exposed area of the rod.

For the storing position, see "PRECAUTIONS FOR LONG-TERM STORAGE" in Chapter 3.

### 3.14.2 OPERATION AT SEASHORE

After operation, wash the machine carefully to remove salt, and apply anti-rust treatments with oil and grease, if necessary.

### 3.14.3 OPERATION IN SANDY AND DUSTY AREAS

- Clean and change the air cleaner element earlier than the specified interval.
- Clean the radiator earlier than the specified interval to prevent the radiator core from being clogged with dust.
- Be careful to prevent dust entering when refueling, and refilling oils. Inspect the filter element earlier than the specified interval.
- Especially, clean the starter and alternator earlier than the specified interval to prevent deposit of dust on them.

## 3.15 PRECAUTIONS FOR LONG-TERM STORAGE

When storing the machine for a long period (one month or longer), maintain the machine with attention to the following points, to prevent decrease in function at the next operation.

### 3.15.1 WASHING MACHINE

Wash the machine thoroughly, inspect and maintain the travel system components and apply touch-up to the peeling paint and scratches. Apply grease to the greasing points.

---



DO not wash the inside of the cab.

When washing the machine, cover the CPU and the electric components to prevent water or steam from splashing on or contacting with them.

---

### 3.15.2 REFILLING OIL/GREASING

Check the level and contamination of the fuel and hydraulic oil. Refill the oil if the level is low, and replace the oil if the oil is contaminated.

- To prevent condensation in the fuel tank, supply new clean fuel fully to the upper limit.
- Apply a sufficient quantity of anti-rust oil to any parts which rust easily, especially to the exposed area of each cylinder piston rod.

### 3.15.3 BATTERY

- To compensate the self-discharge during storage, perform auxiliary charge at least once a month.
  - If the battery power-off switch is equipped, set the battery power-off switch to the "OFF" position to cut off the current.
  - Remove the negative (-) terminal from the battery, and remove the battery from the machine for storage. Be careful not to connect the negative (-) terminal of the battery to the body (ground terminal) with a tool when removing the battery. It will cause short circuit even when the battery power-off switch is set to "OFF".
- 



Before turning the battery power-off switch to the "O (OFF)" position or removing the terminal of the battery, turn the starter switch to the "OFF" position and wait 5 minutes or more.

When turning off the battery power-off switch immediately after the engine is stopped, the exhaust gas cleaning device may be damaged.

---

### 3.15.4 COOLANT

If there is a possibility of freezing, mix the antifreeze (non-amine type) into the radiator.

However, normally it is not necessary because long life coolant is already mixed at the time of shipment. See "LUBRICANT, FUEL & COOLANT SPECIFICATIONS" in Chapter 4.



### 3.15.5 PREVENTION OF DUST AND MOISTURE

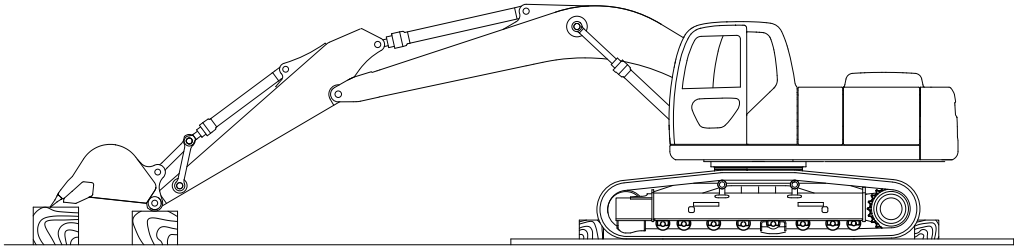

Store the machine in a dry indoor location. If you place the machine outside unavoidably, lay ladders on a flat ground and cover the machine with a sheet. Especially, cover the muffler, hydraulic oil tank breather, fuel tank cap, and swing motor level gauge.

To protect the exposed part of the rod, fully retract the arm and bucket cylinders, be sure to place the bucket on the ground and chock the crawlers.

### 3.15.6 PERIODICAL LUBRICATING OPERATION (DURING STORAGE)

Once a month, start the engine to operate the machine and also move the working devices to supply the hydraulic oil to each part. If the oil film shortage occurs on parts and rust is formed on parts, it may cause abnormal wear at the next operation.

- Check the engine oil level and coolant level before starting the engine. Refill engine oil or coolant if its level is low.
- Wipe off the anti-rust oil from the cylinder rods. After the lubricating operation, apply the anti-rust oil again.
- After starting the engine, fully warm-up the machine and repeat the traveling, swing and digging operations several times to prevent lubricant oil film shortage.
- If the machine is stored indoors, adequate ventilation is required during warming-up.

#### Lubricating operation

1. Slowly extend and retract each cylinder several times and circulate the hydraulic oil in all operation circuits.
2. Also perform swing and traveling slowly to circulate the hydraulic oil.

### 3.15.7 TREATMENT AFTER LONG-TERM STORAGE

When starting to use the machine after a long-term suspension, perform the following treatments.

- Loosen the plugs of the travel reduction unit and swing reduction unit and remove the dust and water which deposited during the long-term storage.
- Lubricant gets deteriorated while the machine is not in use. Use extreme caution when starting to use the machine at the next time.
- Check the deterioration of the hydraulic hoses carefully after the long-term storage. Replace the deteriorated hoses.
- Wipe off the anti-rust oil from the cylinder rods.
- Refill oil and grease to all necessary parts.
- Check the engine oil level and coolant level before starting the engine. Refill engine oil or coolant if its level is low.
- After starting the engine, fully warm-up the machine and repeat the traveling, swing and digging operations several times to prevent hydraulic oil film shortage.
- If the machine is stored indoors, adequate ventilation is required during warming-up.
- When DEF/AdBlue in the DEF/AdBlue tank is past the expiration intervals shown in the table below, ask your KOBELCO authorized dealer for changing DEF/AdBlue. DEF/AdBlue that becomes old sometimes emits the ammonia acrid odor, so do not smell that.

Storage ambient temperature	Expiration interval
10 degrees C (50 degrees F) or less	36 months
25 degrees C (77 degrees F) or less	18 months
30 degrees C (86 degrees F) or less	12 months
35 degrees C (95 degrees F) or less	6 months
Exceeds 35 degrees C (95 degrees F)	1 month

# 4. INSPECTION AND MAINTENANCE



## 4.1 GENERAL



### INSPECTION AND MAINTENANCE ON THE MACHINE

Thoroughly read and understand the safety precautions contained in this manual before performing any inspection or service procedures on systems or components of this machine.

- Regular inspection and maintenance enable this machine to achieve the full function and extend the service life of each part.
- The information contained in this chapter gives the proper procedures for performing inspection and maintenance of this machine. Use these procedures when performing inspection and maintenance as they will guide the technician step by step for each procedure. Also, see "INSPECTION AND MAINTENANCE CHART" for general service interval recommendations.
- As a general rule, the period of the lubrication and maintenance is determined by the hour meter. If the hour meter reading matches roughly with the calendar day, and if you would like to schedule them based on the calendar day, take whichever comes first. For items which do not have a certain service time, see "WHEN REQUIRED".

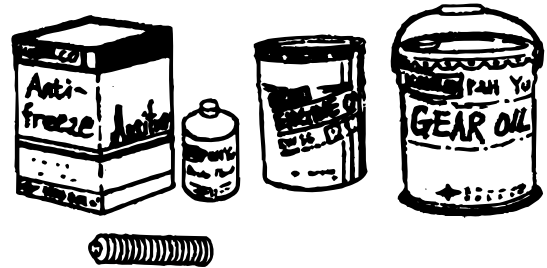

#### Notice

As a general rule, the period of the lubrication and maintenance is determined by the hour meter. If the hour meter reading matches roughly with the calendar day, and if you would like to schedule them based on the calendar day, take whichever comes first. For items which do not have a certain service time, see "WHEN REQUIRED".

- Use only specified oils, fluids, lubricants, filters and replacement parts to keep machine in optimum operating condition. Use the oils and greases with the specified viscosity depending on the ambient temperature. Store containers of oils, fluids and grease indoors in an appropriate location. To prevent dust and water intrusion, keep the containers of oil, fluid, and lubricant in a proper indoor place.

## 4.2 INSPECTING AND MAINTAINING MACHINE

### 4.2.1 PERIODIC INSPECTION AND MAINTENANCE

Regular inspection and maintenance enable this machine to achieve the full function and extend the service life of each part. Inspection and maintenance schedules are given in both the calendar time and the operation time. Take either schedule whichever comes first. For items which do not have a certain service time, see "WHEN REQUIRED". Also, operation in sites under severe work conditions or with a lot of dust and moisture may need more frequent lubrication and maintenance than the service times specified there.

### 4.2.2 PRECAUTIONS OF INSPECTION AND MAINTENANCE

Use inspection and maintenance procedures described in this manual. Park the machine on a level and firm ground before inspection and maintenance.

---

#### Notice

For the adjustment, disassembling and repair of the engine, reduction unit, hydraulic component and electronic devices (controller, etc.), contact your KOBECO authorized dealer.

---

#### **STOP THE ENGINE BEFORE INSPECTION AND MAINTENANCE**

Be sure to stop the engine before inspection and maintenance of the engine. Inspecting and maintaining the running engine may cause injury by being caught in the cooling fan or fan belts. When running the engine is unavoidable during the inspection or maintenance, it should be done by at least two persons with the condition that one person can stop the engine at any time and they are communicating with each other.

#### **PUT THE WARNING TAGS**

Put the tags "DO NOT START ENGINE!", "DO NOT OPERATE" and "UNDER INSPECTION/MAINTENANCE" on noticeable places such as around the operator's seat as well as the starter switch or control levers before inspection and maintenance.

#### **USE OUR GENUINE PARTS**

- For replacement of parts, grease and oil, be sure to use KOBELCO genuine parts. Use grease and oil with the specified viscosity depending on the ambient temperature.
- Store containers of greases and oils in a clean room to keep them away from dust and water.

#### **KEEP OUT DUST**

Attach a plug or cap to the lubrication hole of a removed hydraulic hose or hydraulic component to keep out foreign materials.

#### **INSPECT DRAIN OIL AND FILTERS**

When replacing oil or filter, check the drain oil or old filter for metallic powder or other foreign materials mixed. Contact the person in charge and take appropriate measures if any foreign materials are found.

#### **HANDLING OF WASTE OIL AND ANTIFREEZE**

Be sure to drain waste oil and antifreeze in containers and ask a public service company for disposal of them as the industrial waste.

#### **CLEAN THE SEALING SURFACE**

After removing the O-ring or gasket seal, clean the sealing surface to replace it with a new one. Apply thin oil to the O-ring or seal and attach it into the groove correctly.

#### **DO NOT MIX OILS**

Never mix different kinds of oil. When using another kind of oil, replace the total amount of old oil.

### 4.2.3 SUPPORT STAY

The support stays are provided on the side doors and the engine hood.  
When opening the side doors and the engine hood, be sure to fix them with the stays

**CAUTION**

Before performing inspection or maintenance, be sure to fix the opened side doors and the opened engine hood with the support stays to prevent them from moving, resulting in personal injury.

#### Stay fixed by hole

Open the door, and put stay (1) into fixing hole (2) to fix the stay.

Before closing the door, remove the stay from the fixing hole, return it to the original position, and then close the door.

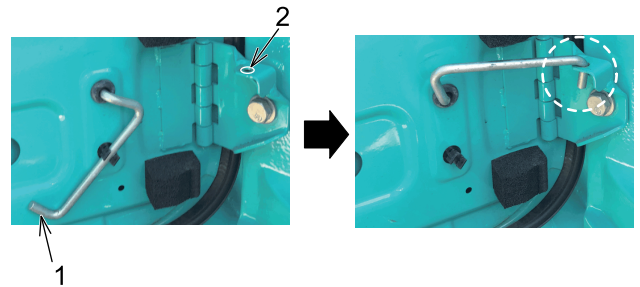

#### Slide type stay

Open the door, slide stay (1) to fixing part (2) of the guide to fix the stay.

Before closing the door, remove the stay from fixing part (2) and then close the door.

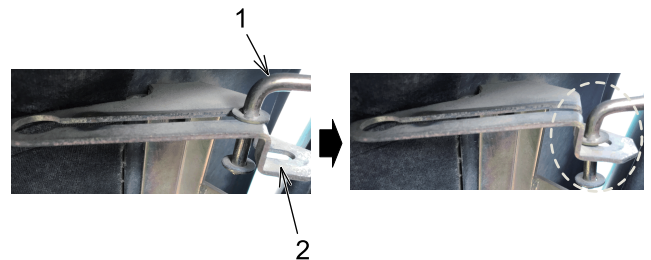
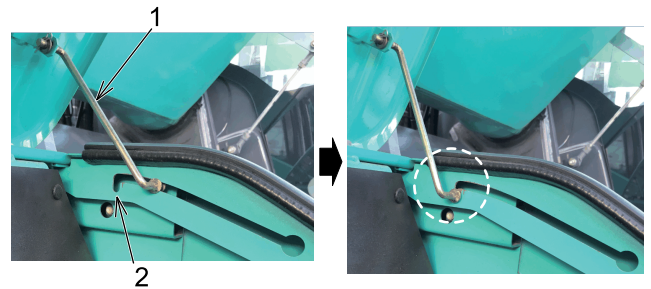

## 4.3 EXHAUST GAS CLEANING DEVICE (DOC)

### 4.3.1 ABOUT EXHAUST GAS CLEANING DEVICE

The exhaust gas cleaning device purifies exhaust gas emitted from the engine, using the catalyst.

After a certain amount of time has passed, the exhaust gas cleaning device enters the mode to regenerate the catalyst.

This mode brings a poor catalyst performance back to a proper performance. It is called "purge" (regeneration). Be sure to comply with the following to prevent failure.

---

#### Notice

After a certain amount of time has passed, the exhaust gas cleaning device starts regeneration of the catalyst automatically according to the operating conditions. This keeps the purification ability of the catalyst in good condition at all times. For details, see "ABOUT AUTOMATIC REGENERATION".

---

### 4.3.2 ABOUT AUTOMATIC REGENERATION

If an exhaust temperature is high after a certain amount of time has passed, the exhaust gas cleaning device automatically enters the mode to regenerate the catalyst.

At this time, the indication of regenerating is displayed on the monitor.

After the regeneration is completed, this indication disappears and the machine returns to a normal condition automatically.



REGEN. IS BEING CARRIED OUT  
HI TEMP. AROUND MUFFLER

#### CAUTION

Immediately after the machine operation and during the regeneration, the temperature around the exhaust pipe and muffler and of the exhaust gas are very high. Putting any combustible materials close to these hot parts, could cause a fire. Touching hot exhaust gas may cause burns.

---

#### Notice

In some operating conditions, the automatic regeneration is not completed and the warning requesting the user to perform manual regeneration is displayed on the monitor. In this case, perform the manual regeneration, referring the next Paragraph "ABOUT MANUAL REGENERATION".

---

In the following operations, the automatic regeneration may be difficult to complete.

- At engine start, when the control lever is pulled up to the "LOCKED" position and most of the times the levers are not operated.
  - When many operations at a low speed of the engine are performed.
  - When the engine is started and stopped frequently
  - When the operation is performed in an extremely cold place
  - When there are many low-load operations
  - When the engine is operated and stopped while it is still not warm
- 

#### Notice

Even though a certain amount of time has not passed, sometimes the display shown above can appear.

---



### 4.3.3 ABOUT MANUAL REGENERATION

 1. LIFT UP LOCK LEVER  
2. PUSH REGENERATION SW.

When this warning is displayed on the monitor, perform manual regeneration immediately.

#### Notice

- The exhaust gas cleaning device starts the automatic regeneration after a certain amount of time has passed, but it may not be completed in some operating conditions.  
When the automatic regeneration is not completed and a certain amount of time has passed, the above warning is displayed and the warning sounds. In that case, perform the manual regeneration in the following procedures.
- When the manual regeneration is not performed, the exhaust gas cleaning device fails and the engine speed is restricted.

#### OPERATION METHOD

#### CAUTION

- Immediately after the machine operation and during the regeneration, the temperature around the exhaust pipe and muffler and of the exhaust gas are very high. Putting any combustible materials close to these hot parts, could cause a fire. Touching hot exhaust gas may cause burns.
- Before starting manual regeneration, stop the machine operation (such as digging, lifting, shearing, or breaker). During regeneration, the attachment/equipment may slowly move to the internal direction but this is not failure. If the manual regeneration is performed with the attachment/equipment raised, the attachment/equipment may move unexpectedly.  
During the regeneration, keep the boom/arm away from the bucket teeth.

1. Move the machine to a safe place.
2. Place the machine in the parking position and move the pilot control shut-off lever to the "LOCKED" position.

## [4. INSPECTION AND MAINTENANCE]

3. Press manual regeneration switch (1).  
Indication of regenerating (2) is displayed on the monitor. The engine speed is fixed and the machine enters the mode for regeneration.
4. When indication (2) goes off, the manual regeneration is completed.  
When the engine is stopped during the manual regeneration or when the pilot control shut-off lever is set to the "UNLOCKED" position, the regeneration is paused.  
In that case, perform the manual regeneration again.

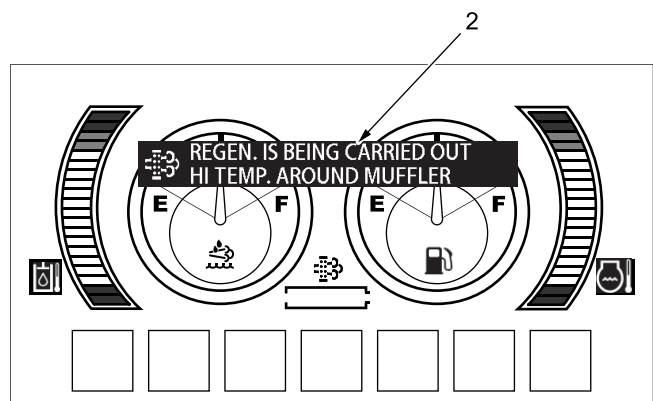
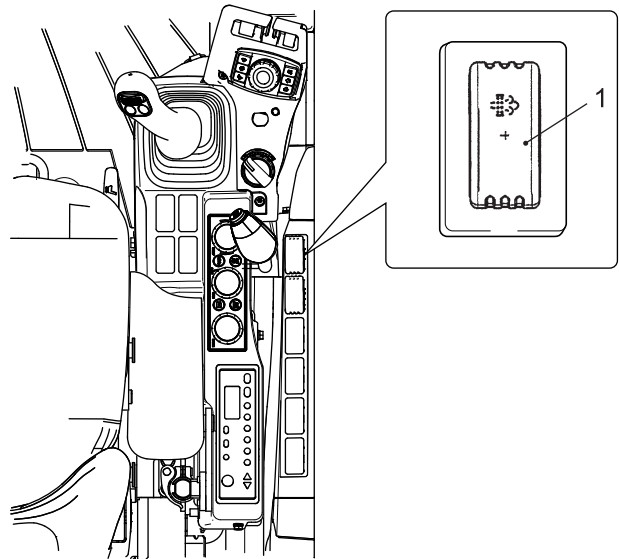

### Notice

- It takes about 10 to 20 minutes to complete the manual regeneration.
- Regeneration is performed by increasing the temperature inside the muffler to a certain level. Therefore, the process completes faster if it is performed immediately after operation, when the temperature inside the muffler is high.
- It may take more than 20 minutes for combustion when the engine is cool because warming-up is needed before combustion.

### 4.3.4 INSPECTION AND MAINTENANCE

- Inspection interval: Every 1,000 hours (or every 1 year)  
You need to check the body of the exhaust gas cleaning device for damage, including the sensor cables attached to the body. If failures are found during inspection, replace the failure parts immediately.  
For inspection and replacement, contact KOBELCO or your KOBELCO authorized dealer.
- The inspection and maintenance are needed every 2 years for the body of the exhaust gas cleaning device and the sensor cables and hoses attached to the body, and the mount. For inspection and maintenance, contact KOBELCO or your KOBELCO authorized dealer.

---

## 4.3.5 PRECAUTIONS OF USING EXHAUST GAS CLEANING DEVICE

### USE SPECIFIED FUEL ONLY

---

**Notice**

Use the specified fuel described in "LUBRICANT, FUEL & COOLANT SPECIFICATIONS" in Chapter 4.  
If you use fuel other than the specified fuel, it has an adverse effect on the engine and the exhaust gas cleaning device, causing white smoke and malfunction.

---

### USE SPECIFIED ENGINE OIL ONLY

---

**Notice**

Use the specified engine oil described in "LUBRICANT, FUEL & COOLANT SPECIFICATIONS" in Chapter 4.  
Use the specified engine oil to keep the function of the exhaust gas cleaning device normal for a long time.

---

### PROHIBITION OF ENGINE PIPE DISASSEMBLY

---

**Notice**

Do not remove the exhaust pipe or disassemble the muffler and parts around it. This may affect the performance of exhaust gas cleaning device adversely or break it.

---

## 4.4 SCR SYSTEM AND DEF/ADBLUE

This machine is equipped with SCR (Selective Catalytic Reduction) system for NOx (nitrogen oxidate) discharge reduction.

### 4.4.1 SCR

SCR equipped with this machine reduces NOx in exhaust gas by injecting DEF/AdBlue into the muffler to resolve NOx in the exhaust gas into water and nitrogen.

### 4.4.2 DEF/AdBlue

DEF/AdBlue is used for the SCR system on this machine. Use only specified DEF/AdBlue.

---

#### CAUTION

- DEF/AdBlue should meet ISO 22241-1 or JIS K2247-1.
  - Do not put diesel fuel or water in the DEF/AdBlue tank.
  - Follow the precautions for handling DEF/AdBlue specified by the manufacturer.
- 

### 4.4.3 DEF/AdBlue CIRCUIT AND BATTERY

#### CAUTION

Before removing the battery terminals, turn the starter switch to the OFF position and wait 5 minute or more. If the battery power is turned off immediately after stopping the engine, it may cause damage to the exhaust gas cleaning device.

---

#### Notice

Even after turning the engine OFF, you may hear running sound of the DEF/AdBlue supply module. To prevent DEF/AdBlue remaining in the DEF/AdBlue pipe from freezing and drying, DEF/AdBlue is returned to the tank with the DEF/AdBlue supply module.

---

### 4.4.4 STORING DEF/ADBLUE

#### Notice

DEF/AdBlue freezes at - 11 degrees C (12 degrees F). The container may be damaged from volume expansion due to freezing.

---

- DEF/AdBlue should be stored in a place without direct sunlight and with well ventilation, with its container sealed.
- Do not mix DEF/AdBlue with other chemicals, heat it, or dilute it with water.

### 4.4.5 PURCHASING DEF/ADBLUE

DEF/AdBlue can be purchased in the following places or confirm where to purchase.

- Gas stations and stores that sell automobile goods.
- DEF/AdBlue manufacturers
- KOBELCO authorized dealer/distributor





## 4.4.6 LOW DEF/ADBLUE LEVEL

### Notice

If the pointer of the monitor points the yellow or red range, immediately supply DEF/AdBlue until the pointer points the place higher than the yellow range.

When DEF/AdBlue becomes low, restriction is applied to the engine output.

When the following warnings are displayed in the multi-display, see "CHECKING DEF/ADBLUE LEVEL AND REFILLING" to supply DEF/AdBlue.

Level	Warning Display	Contents
1st Level	 DEF/ADBLUE LEVEL LOW	Displayed with the warning sound when the pointer of the DEF/AdBlue level gauge points the yellow range.
2nd Level	 DEF/ADBLUE LEVEL LOW  POWER LIMITATION IN PROGRESS	Displayed with the warning sound when the pointer of the DEF/AdBlue level gauge points the yellow range. Gradually, a restriction is applied to the engine output.
3rd Level	 DEF/ADBLUE TANK IS EMPTY  EXTREME POWER LIMITATION IN PROGRESS	Displayed with the continuous warning sound when the pointer of the DEF/AdBlue level gauge points the E point. The engine output is further restricted than Level 2.

## 4.4.7 QUALITY PROBLEMS OF DEF/ADBLUE





### CAUTION

- Use DEF/AdBlue which meets ISO 22241-1 or JIS K2247-1.
- Do not add diesel fuel or water in the DEF/AdBlue tank.
- Follow the precautions for handling DEF/AdBlue specified by the manufacturer.

When the following warnings are displayed on the multi-display, something other than DEF/AdBlue is in the DEF/AdBlue tank. See "DRAINING DEF/ADBLUE" and "CHECKING DEF/ADBLUE LEVEL AND REFILLING" to drain and refill DEF/AdBlue.

If the machine is operated with the DEF/AdBlue in abnormal quality, the engine output is restricted.

Also, when something else than DEF/AdBlue is put in the tank and the engine is started, the DEF/AdBlue pipes and the DEF/AdBlue supply module may need to be replaced.

LEVEL	Warning Display	Description
Level 1	 POOR DEF/ADBLUE QUALITY DETECTED	Displayed with the warning sound when the DEF/AdBlue sensor determines the quality problem of DEF/AdBlue.
Level 2	 POOR DEF/ADBLUE QUALITY DETECTED  POWER LIMITATION IN PROGRESS	Displayed with the warning sound when a certain period of time has passed from Level 1. The engine output is gradually restricted.
Level 3	 POOR DEF/ADBLUE QUALITY DETECTED  EXTREME POWER LIMITATION IN PROGRESS	Displayed with the continuous warning sound when a certain period of time has passed from Level 2. The engine output is further restricted than Level 2.

### Notice

When failure of the DEF/AdBlue quality or the exhaust gas cleaning device occurs repeatedly, the warning level goes up. If another failure of the DEF/AdBlue quality or the exhaust gas cleaning device occurs in a short period of time after the failure of that is corrected, the warning level starts from Level 3.

### 4.4.8 DRAINING DEF/ADBLUE

In case of draining the content of the DEF/AdBlue tank is required like when the warning for abnormal DEF/AdBlue quality appears, follow the next procedures.



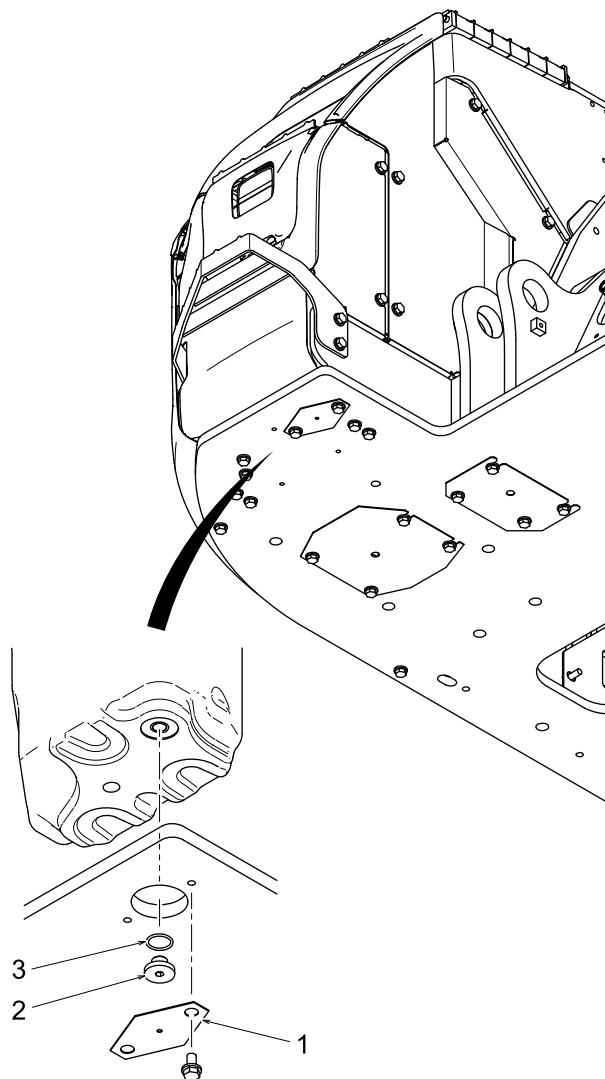

























1. Prepare a container to receive drained DEF/AdBlue and cloths to wipe it off.
2. Remove cover (1) on the bottom of the DEF/AdBlue tank.
3. Remove drain plug (2) and O-ring (3) of the DEF/AdBlue tank, and start draining DEF/AdBlue.
4. After draining DEF/AdBlue, attach O-ring (3) and drain plug (2).  
Tightening torque of plug:  $50 \pm 5 \text{ N} \cdot \text{m}$  ( $36.9 \pm 3.7 \text{ lbf} \cdot \text{ft}$ )
5. Attach cover (1).
6. See "CHECKING DEF/ADBLUE LEVEL AND REFILLING" in Chapter 3 to supply DEF/AdBlue.
7. After the supply, check no warning is displayed on the monitor.



### 4.4.9 FAILURE OF EXHAUST GAS CLEANING DEVICE

When the following warnings are displayed on the monitor, the exhaust gas cleaning device has a failure or an error.

When keep operating with the exhaust gas cleaning device having a failure or an error, the engine output is restricted and, in the end, the machine becomes inoperable. When these warnings are displayed, contact our service factory.

LEVEL	Warning Display	Description
Level 1	   	Failure of NOx exhaust control system (Error code is example)
	  	Failure of DEF/AdBlue dosing module (Error code is example)
	  	Failure of EGR valve (Error code is example)
Level 2	  	Failure of NOx exhaust control system (Error code is example)
	  	Failure of DEF/AdBlue dosing module (Error code is example)
	  	Failure of EGR valve (Error code is example)
Level 3	  	Failure of NOx exhaust control system (Error code is example)
	  	Failure of DEF/AdBlue dosing module (Error code is example)
	  	Failure of EGR valve (Error code is example)

#### Notice

When failure of the DEF/AdBlue quality or the exhaust gas cleaning device occurs repeatedly, the warning level goes up. If another failure of the DEF/AdBlue quality or the exhaust gas cleaning device occurs in a short period of time after the failure of that is corrected, the warning level starts from Level 3.

#### 4.4.10 EMERGENCY EVACUATION MODE

If the machine should be moved to somewhere emergency even though the machine is in a state of the third level of warning and under engine restriction due to DEF/AdBlue shortage, abnormal quality, or a failure of the exhaust gas cleaning device, keep pressing buzzer stop switch (5) and return switch (6) on the switch box for 5 seconds to enter the emergency evacuation mode.

However, operations other than traveling are restricted, so normal operations become impossible.

#### **CAUTION**

- The emergency evacuation mode can be used for only total 30 minutes. Use this mode only in a case of emergency and if the warnings are displayed, take proper measures immediately.
- When entering the emergency evacuation mode, surely keep pressing buzzer stop switch (5) and return switch (6) on the switch box for 5 seconds.  
If not keep pressing them for 5 seconds securely, the machine will not enter the emergency evacuation mode.

#### Switch box

- (1) Jog dial
- (2) Wiper switch
- (3) Washer switch
- (4) Travel speed select switch
- (5) Buzzer stop switch
- (6) Return switch
- (7) Home switch

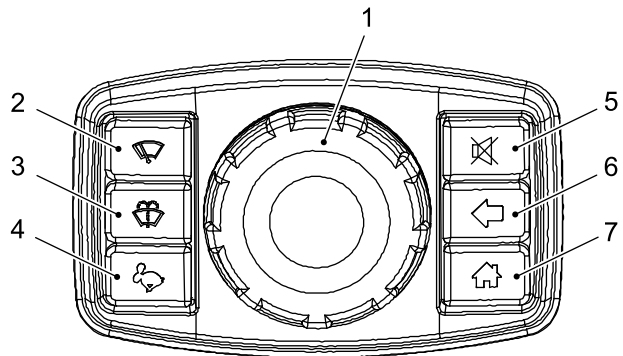

#### 4.4.11 SCR INSPECTION AND MAINTENANCE

There are parts in SCR that require a periodical inspection and maintenance. (See "SCR SYSTEM" of "INSPECTION AND MAINTENANCE CHART" in Chapter 4 in the operation manual.)



## 4.5 LUBRICANT, FUEL & COOLANT SPECIFICATIONS

Regardless of the outdoor temperature, the following reduction units use the following oil:

- Swing reduction unit: Gear oil #90, API classification GL-4 class
- Travel reduction unit: Gear oil #90, API classification GL-4 class

Components	Type of Lubricant	Capacities (When changed)	Climate Zone								Specified Lubricant			
			-22 -30	-4 -20	14 -10	32 0	50 10	68 20	86 30	104 °F 40 °C				
Hydraulic oil tank	Hydraulic oil	89.9 Liters (24 Gal) 176 Liters (64.5 Gal) (Hydraulic system)											(KOBELCO BRAND) Long life hydraulic oil KW5046 P/No. KAPYN01T01066D3	
Engine oil pan	Engine oil	[Total volume] 17.0 Liters (4.5 Gal) [H level] 15.0 Liters (4.0 Gal) [L level] 11.0 Liters (2.9 Gal)											(KOBELCO BRAND) A.P.I CJ-4 ACEA E9, E6 JASO DH-2 P/No. KAPYN01T01077D1	
Swing motor reduction unit	Gear oil	1.65 Liter (0.4 Gal)											(KOBELCO BRAND) A.P.I classification for "service GL-4" P/No. KAPSP90020	
Travel motor reduction unit		2.1 Liter X 2 (0.6 Gal X 2)												
Swing motor reduction unit (Housing)	EP grease	0.4 kg (0.9 lbs)											(KOBELCO BRAND) Extreme pressure multipurpose grease  Cartridge P/No. KAPG0420D1 (400g x 20 units)  Pail can P/No. KAPG1601D1	
Attachment pins		16 places												
Slewing ring gear		1 place												
Track tension Adjustment		2 places												
Operating lever (Pilot valve)		As required												
Swing gear		8.2 kg (18.0 lbs)												
Fuel tank	Diesel fuel	186 Liters (49.1 Gal)											ASTM D-975	
														EN 590
Diesel exhaust flued tank APPLICABLE No. YY09045001-YY09046176 LH04006001-LH04006031	DEF / AdBlue	20.7L (5.5 Gal)											ISO 22241-1	
Diesel exhaust flued tank APPLICABLE No. YY09046177-LH04006032-	DEF / AdBlue	26 L (6.9 Gal)											ISO 22241-1	
Radiator (Reserve tank)	Engine coolant (Antifreeze)	16 L (Total volume 9 L)											(KOBELCO BRAND) Do not mix and use different types of coolants. P/No. KAPYN01T01110D1	

## [4. INSPECTION AND MAINTENANCE]

---

---

### Notice

- When oil leakage or damage of the lower roller, upper roller and front idler is recognized, contact your KOBELCO authorized dealer for repair.
  - Be sure to use the specified fuel. To achieve a good fuel efficiency and exhaust gas property, the engine of this machine uses the electronically controlled fuel injector.  
Because this device requires high parts precision and high lubricating ability, when low viscosity fuel with low lubricating ability is used, the durability may decrease significantly.
- 
- 

### Notice

When replacing and refilling the long life hydraulic oil, use the oil specified by KOBELCO.

When non-specified hydraulic oil is used or mixed, the performance decreases and the replacement interval of hydraulic oil needs to be shortened.

---

---

### Notice

This machine is intended to be operated in the range of -20 degrees C to 40 degrees C (-4 degrees F to 104 degrees F).

---

## 4.6 ABOUT USE OF BIO-OIL (BIODEGRADABLE HYDRAULIC OIL)

### 4.6.1 GREASE AND OIL FOR USE

Regarding greases and oils for use, ask your KOBELCO authorized dealer.

### 4.6.2 PRECAUTIONS FOR BIO-OIL

- When charging bio-oil to a machine using conventional mineral oil, perform flushing three times. Without flushing, the mineral oil in the circuit is not completely cleaned and the effect of biodegradability cannot be expected.
- Because the friction coefficient of bio-oil is smaller than that of mineral oil, the performance of parking brakes for swing and travel decrease.

### 4.6.3 REPLACEMENT INTERVAL OF BIO-OIL

Bio-oil should be replaced every 2,000 hours.

For replacing procedures, see "CHANGING HYDRAULIC OIL" in Chapter 4.

### 4.6.4 FLUSHING PROCEDURES OF BIO-OIL

1. Drain all mineral oil from the hydraulic oil tank.
2. Drain all mineral oil from the cylinders.
3. Charge new bio-oil in the hydraulic oil tank fully.
4. After starting the engine, operate each cylinder for 10 strokes respectively.

---

**CAUTION**

Rapid operation may burn the seal because of the air remained in the cylinder. During the first 4 strokes, operate the cylinder slowly with the engine speed at low idle to charge the hydraulic oil in the cylinder.

5. Idle the right and left travel motors for about 3 minutes respectively.
6. Perform the swing operation for 10 turns.
7. Drain all bio-oil from the hydraulic oil tank.
8. Drain all bio-oil from each cylinder.
9. Charge new bio-oil in the hydraulic oil tank and repeat the procedures 4 to 9 twice.
10. In the final state, analyze the hydraulic oil and check the remaining amount of mineral oil.

## 4.7 MAINTENANCE PARTS

Replace parts, such as filters and elements, during the periodical maintenance or before the end of the service life. The machine can be used economically if the maintenance parts are changed properly and timely.

The part numbers are subject to change without notice.

When placing an order of parts, ask your KOBELCO authorized dealer for the part numbers.

### MAINTENANCE PARTS LIST

Item	Part Number	Part Name	Q'ty	Replacement Interval	
Hydraulic oil tank	YN52V01025R200	Return filter element kit (STD, Breaker)	1	Replace at 50 hours for the first time, then every 1000 hours (every 250 hours with breaker specification)	
Hydraulic oil tank	LQ50V00004F1	Suction strainer	1	Clean every 2000 hours	
Air breather	YN57V00012S002	Element	1	Replace every 1000 hours. Replacement every 1000 hours is just a rough guideline. If the machine is operated in very dusty conditions, replace the element earlier.	
Air cleaner	LP11P00015S005	Element (Outer)	1	Replace every 6 times cleaning or every 1 year	
	LP11P00015S006	Element (Inner)	1	Replace at the same time with the outer element (do not clean)	
	LP11P00015S002	O-ring	1	When required	
Engine oil filter	VI8983020750	Cartridge	1	Replace at 50 hours for the first time, then every 500 hours	
Fuel filter	Main	VI8983129180	Cartridge	1	Replace every 500 hours
	Pre	YN21P01068R100	Element	1	
Air conditioner	YT50V01036P1	Fresh air filter	1	Replace after 10 times cleaning. When clogging is severe, replace the filter.	
	LQ50V01007P1	Recirculation air filter	1		
Pilot line filter	YN50V00020F1	Pilot line filter	1	Clean every 2000 hours	
Radiator	YY05P00061S005	Radiator cap	1	Replace every 1000 hours	
Bucket (STD)	2412N278D11	Side cutter	1	When required	
	2412N278D21	Side cutter	1		
	ZS13C20050	Bolt	8		
	ZN13C20016	Nut	8		
	2412U16F1	Tooth assembly	5		
Built-in battery for communication controller	YN22E00643S001	Battery	1	Replace every year	

#### Notice

- The built-in battery for communication controller needs to be replaced every year. For replacement, contact your KOBELCO authorized dealer.

## 4.8 TIGHTENING TORQUES FOR BOLTS & NUTS (SPECIFIC POSITIONS)

Follow the next table when tightening or retightening bolts or nuts in every part.

Check for any loose or missing bolts or nuts before daily operation and at periodical inspection. Retighten a loose bolts and nuts and supply new parts for missing ones as required.

Inspection and retightening are needed at first 50 hours for a new machine and after that every 250 hours. Except for the retightening positions indicated in the following table, retighten the bolts and nuts according to the tightening torque table in "TIGHTENING TORQUE FOR BOLTS & NUTS" in Chapter 4.

Size (M)	Width across Flats mm	Position of bolts/nuts	Tightening torque N·m (Without Lubrication)	Recommended thread locking agent
M5	-	Installing fuel tank level sensor	1.96±0.2 (1.45±0.15)	
M8	13	Installing condenser	11±1.1 (8.11±0.81)	
	13	Installing water sub-tank	10.7±1.1 (7.89±0.81)	
M10	17	Condenser mounting bracket	46.5±4.6 (34.3±3.39)	
	17	Installing swivel joint dust cover	14.7±1.5 (10.8±1.11)	Applying Loctite #572
	17	Installing swing bearing access panel cover	29.4±2.9 (21.7±2.14)	Applying Loctite #572
	17	Installing air cleaner	39±3.9 (28.8±2.88)	
	17	Installing engine oil filter	46.5±4.6 (34.3±3.39)	
	17	Installing hydraulic oil tank cover	46.5±4.6 (34.3±3.39)	
	17	Installing fuel tank bottom cover	46.5±4.6 (34.3±3.39)	
	17	Installing lower frame grease bath cover	10.8±0.98 (7.97±0.72)	
	17	Installing hand rail	46.5±4.6 (34.3±3.39)	Applying Loctite #262
	17	Installing floor plate rubber mount	46.5±4.6 (34.3±3.39)	
M12	19	Installing swivel joint	107.8±10.8 (79.5±7.97)	Applying Loctite #262
	19	Installing bracket for power take	64.7±6.4 (47.7±4.72)	Applying Loctite #262
	19	Installing hand rail	80±8 (59.0±5.90)	
	19	Installing hand hold	115±12 (84.8±8.85)	Applying Loctite #242
	19	Installing cab	80±8 (59.0±5.90)	
	19	Installing travel motor cover	83.4±8.4 (61.5±6.20)	Applying Loctite #262
	19	Front idler idler adjuster connection	115±12 (84.8±8.85)	Applying Loctite #262
M16	24	Installing engine	191±19 (141±14.0)	Applying Loctite #271
	14	Installing main pump	235±24 (173±17.7)	Applying Loctite #262
	14	Installing power take coupling	220±10 (162±7.38)	
	24	Installing travel motor	279±29 (206±21.4)	Applying Loctite #262
	24	Floor plate rubber mount mounting nut	191±19 (141±14.0)	
	24	Installing sprocket	279±29 (206±21.4)	Applying Loctite #262
	24	Installing lower roller	279±28 (206±20.7)	Applying Loctite #262
	24	Installing fuel tank	191±19 (141±14.0)	Applying Loctite #262
	24	Installing shoe bolts	412±39 (304±28.8)	
	24	Installing swing bearing (outer race)	256±25.6 (189±18.9)	Applying Loctite #262

#### [4. INSPECTION AND MAINTENANCE]

Size (M)	Width across Flats mm	Position of bolts/nuts	Tightening torque N·m (Without Lubrication)	Recommended thread locking agent
M16	24	Installing swing bearing (inner race)	279±29 (206±21.4)	Applying Loctite #262
	24	Installing hand rail	191±19 (141±14.0)	
M20	30	Installing hydraulic oil tank	370±37 (273±27.3)	Applying Loctite #262
	30	Installing upper roller	539±54 (398±39.8)	Applying Loctite #262
	30	Installing swing reduction unit	539±54 (398±39.8)	Applying Loctite #262
M24	36	Installing cab	191±19 (141±14.0)	
M27	41	Installing counterweight	1.27±0.13kNm (937 ±95.9)	Applying Loctite #262
M33	50	Installing counterweight	1.67±0.17kNm (1232 ±125)	Applying Loctite #262
5/8-18UNF	19	Installing idler adjuster grease nipple	58.8±9.6 (43.4±7.08)	

#### CAUTION

The counterweight mounting bolts may become loose when the counterweight is hit against some solid obstacles during swing operation etc.

Check that the mounting bolts are tightened to the specified torque using a torque wrench.

When loosened, tighten the bolt to the specified torque.

## 4.9 TIGHTENING TORQUES FOR BOLTS & NUTS

For tightening and retightening of bolts which are not specified in the table "TIGHTENING TORQUES FOR BOLTS & NUTS (SPECIFIC POSITIONS)", see the following table.

### METRIC COARSE THREAD (NOT PLATED)

Torque value Unit : N•m {lbf•ft}

Classification		4.8T		7T		10.9T	
		No lubrication	Oil lubrication	No lubrication	Oil lubrication	No lubrication	Oil lubrication
M6	P=1	4.4±0.5 {3.2±0.4}	3.7±0.4 {2.7±0.3}	9.6±1.0 {7.1±0.7}	8.1±0.8 {6.0±0.6}	17.4±1.8 {12.8±1.3}	14.7±1.5 {10.8±1.1}
M8	P=1.25	10.7±1.1 {7.9±0.8}	9.0±0.9 {6.6±0.7}	23.5±2.0 {17.3±1.5}	19.6±2.0 {14.5±1.5}	42.2±3.9 {31.1±2.9}	35.3±3.9 {26.0±2.9}
M10	P=1.5	21.6±2.0 {15.9±1.4}	17.9±1.8 {13.2±1.3}	46.1±4.9 {34.0±3.6}	39.2±3.9 {28.9±2.9}	83.4±8.8 {61.5±6.5}	70.6±6.9 {52.1±5.1}
M12	P=1.75	36.3±3.9 {26.8±2.9}	31.4±2.9 {23.2±2.1}	79.4±7.8 {58.6±5.8}	66.7±6.9 {49.2±5.1}	143±15 {105±11}	121±12 {89.2±8.9}
M14	P=2	57.9±5.9 {42.7±4.4}	49.0±4.9 {36.1±3.6}	126±13 {92.9±9.6}	106±10 {78.2±7.4}	226±20 {167±15}	191±19 {141±14}
M16	P=2	88.3±8.8 {65.1±6.5}	74.5±6.9 {55.0±5.1}	191±20 {141±15}	161±16 {119±12}	343±39 {253±29}	284±29 {209±21}
M18	P=2.5	122±12 {90.0±8.9}	103±10 {75.8±7.2}	265±29 {195±21}	226±20 {167±15}	481±49 {355±36}	402±39 {297±29}
M20	P=2.5	172±17 {127±13}	144±14 {106±10}	373±39 {275±29}	314±29 {232±21}	667±69 {492±51}	559±59 {412±44}
M22	P=2.5	226±20 {167±15}	192±20 {142±15}	500±49 {369±36}	422±39 {311±29}	902±88 {665±65}	755±78 {557±58}
M24	P=3	294±29 {217±21}	235±29 {173±21}	637±69 {470±51}	520±49 {383±36}	1160±118 {856±87}	941±98 {694±72}
M27	P=3	431±39 {318±29}	353±39 {260±29}	941±98 {694±72}	765±78 {564±58}	1700±167 {1250±123}	1370±137 {1010±101}
M30	P=3.5	588±59 {434±44}	490±49 {361±36}	1285±127 {948±94}	1079±108 {796±80}	2300±235 {1700±173}	1940±196 {1430±145}
M33	P=3.5	794±78 {586±58}	667±69 {492±51}	1726±177 {1270±131}	1451±147 {1070±108}	3110±314 {2290±232}	2610±265 {1930±195}
M36	P=4	1030±98 {760±72}	863±88 {637±65}	2226±226 {1640±167}	1863±186 {1370±137}	4010±402 {2960±297}	3360±333 {2480±246}

## [4. INSPECTION AND MAINTENANCE]

### METRIC FINE THREAD (NOT PLATED)

Torque value Unit : N•m {lbf•ft}

Classification		4.8T		7T		10.9T	
		No lubrication	Oil lubrication	No lubrication	Oil lubrication	No lubrication	Oil lubrication
M8	P=1.0	11.3±1.1 {8.3±0.8}	9.5±1.0 {7.0±0.7}	24.5±2.0 {18.1±1.5}	20.6±2.0 {15.2±1.5}	44.1±3.9 {32.5±2.9}	37.3±3.9 {27.5±2.9}
M10	P=1.25	22.6±2.0 {16.7±1.5}	18.7±1.9 {13.8±1.4}	48.1±4.9 {35.5±3.6}	41.2±3.9 {30.3±2.9}	87.3±8.8 {64.4±6.5}	73.5±6.9 {54.2±5.1}
M12	P=1.25	39.2±3.9 {28.9±2.9}	33.3±2.9 {24.6±2.1}	85.3±8.8 {62.9±6.5}	71.6±6.9 {52.8±5.1}	154±16 {114±12}	129±13 {95.2±9.6}
M16	P=1.5	92.2±8.8 {68.0±6.5}	77.5±7.8 {57.2±5.8}	196±20 {145±15}	169±17 {125±13}	363±39 {268±29}	304±29 {224±21}
M20	P=1.5	186±19 {137±14}	155±16 {114±12}	402±39 {297±29}	333±29 {246±21}	726±69 {535±51}	608±59 {448±44}
M24	P=2	314±29 {232±21}	265±29 {195±21}	686±69 {506±51}	569±59 {420±44}	1240±118 {915±87}	1030±98 {760±72}
M30	P=2	637±59 {470±44}	530±49 {391±36}	1390±137 {1030±101}	1157±118 {853±87}	2500±255 {1840±188}	2080±206 {1530±152}
M33	P=2	853±88 {629±65}	706±70 {521±52}	1860±186 {1370±137}	1550±155 {1140±114}	3350±334 {2470±246}	2790±275 {2060±203}
M36	P=3	1070±108 {789±80}	892±88 {658±65}	2330±226 {1720±167}	1940±196 {1430±145}	4200±422 {3100±311}	3500±353 {2580±260}



## 4.10 TIGHTENING TORQUES FOR JOINTS & HYDRAULIC HOSES

**IMPORTANT**

These tightening torques are available in the case of tightening without lubricant.

**ORS FITTING (O-RING SEAL TYPE)**

Hose Mouth and Fitting Size	Wrench (mm)	Tightening torque N · m {lbt · ft}
1 to 14 UNS	30	137 ± 14 {101 ± 10}
	32	
1 to 3/16 to 12 UN	36	177 ± 18 {130 ± 13}
	41	206 ± 21 {152 ± 15}
1 to 7/16 to 12 UN	41	206 ± 21 {152 ± 15}
	46	

**BYTE TYPE TUBE FITTING**

Tube size O.D. x Thickness (mm)	Wrench (mm)	Tightening torque N · m {lbt · ft}
10 * 1.5	19	49 ± 9.8 {36 ± 7}
15 * 2.0	27	118 ± 12 {87 ± 9}
18 * 2.5	32	147 ± 15 {108 ± 18}
22 * 3.0	36	216 ± 22 {159 ± 16}
28 * 4.0	41	275 ± 27 {202 ± 20}
35 * 5.0	55	441 ± 44 {325 ± 33}

**O-RING FITTING**

Screw diameter (PF)	Wrench (mm)	Tightening torque N · m {lbt · ft}
1/8	14	17 ± 2 {12.5 ± 1.5}
1/4	19	36 ± 2 {27 ± 1.5}
3/8	22	74 ± 5 {54 ± 4}
1/2	27	108 ± 9.8 {80 ± 7}
3/4	36	162 ± 9.8 {119 ± 7}
1	41	255 ± 9.8 {188 ± 7}
1 to 1/4	50	392 ± 40 {289 ± 30}
1 to 1/2	55	485 ± 49 {358 ± 36}

## [4. INSPECTION AND MAINTENANCE]

### HYDRAULIC HOSE

Screw diameter (PF)	Wrench (mm)	Tightening torque N · m {lbt · ft}
1/8	17	15 ± 2.0 {11 ± 1.5}
1/4	19	29 ± 4.9 {22 ± 4}
3/8	22	49 ± 4.9 {36 ± 4}
1/2	27	78 ± 4.9 {58 ± 4}
3/4	36	118 ± 9.8 {87 ± 7}
1	41	137 ± 15 {101 ± 11}
1 to 1/4	50	167 ± 15 {123 ± 11}

### SPLIT FLANGE

Nominal Size	Tightening torque N · m {lbt · ft}			
	Working pressure 20.6 Mpa {210 kg/cm <sup>2</sup> }	Bolt size (M)	Working pressure 41.2 Mpa {420 kg/cm <sup>2</sup> }	Bolt size (M)
3/4	33.9 ± 5.6	10	39.5 ± 5.6	10
	{25 ± 4.1}		{29 ± 4.1}	
1	42.4 ± 5.6	10	62.2 ± 5.6	12
	{31 ± 4.1}		{46 ± 4.1}	
1 to 1/4	55.1 ± 7.1	10	93.3 ± 8.4	14
	{41 ± 5.2}		{69 ± 6.2}	
1 to 1/2	70.6 ± 8.4	12	169 ± 11	16
	{52 ± 6.2}		{125 ± 8.1}	
2	81.9 ± 8.4	12	282 ± 11	20
	{60 ± 6.2}		{208 ± 8.1}	

#### IMPORTANT

The tightening torques of the split flange are available in the case of tightening without lubricant.

## 4.11 INSPECTION AND MAINTENANCE CHART

The following charts show the recommended interval or the hour meter reading for each device for greasing, element replacement, and inspection and maintenance items.

Perform inspection and maintenance according to the calendar time or operation time shown by the hour meter, whichever comes first.

### Symbols in the Table

 Indicates a required periodic inspection or maintenance with the hour meter interval.

⊙ Indicates a first one time maintenance interval.

○ Indicates a inspection or maintenance interval.

### ENGINE

Item/Interval		Irregular	Start-Up Inspection	Every 1 Month or	Every 3 Months or	Every 6 Months or	Every 12 Months or	2,000H	4,500H	5,000H	Grease (Replacement Part)	Procedure Description Section	
			8H	50H	100H	250H	500H	1,000H	2,000H	4,500H	5,000H		
Engine oil	Checking oil level		○									Engine oil	3.2.2
	Replacement				⊙ (First time)		○						4.17.1
Replacing oil filter					⊙ (First time)		○					Cartridge	4.17.1
Fuel pre-filter	Draining		○									Cartridge	3.2.4
	Replacement						○						4.17.2
Fuel filter	Replacement						○					Cartridge	4.17.3
Exhaust gas cleaning device	*Inspection							○					4.3.4
Checking air cleaner inlet			○										3.2.13
Air cleaner element	Inspection, cleaning				When the warning lamp is on (until 6 times)	○						Outer element (Inner element is not cleaned)	4.16.5
	Replacement				After 6 times of cleaning of outer element or after 1 year			○				Outer and inner elements	
Cleaning radiator coolant and cooling system	Checking water level		○										3.2.1
	Replacement, cleaning							○ (Or every 2 years)				LLC	4.19.1
Checking radiator hoses for cracking and damage						○							4.16.3
Cleaning radiator, oil cooler core, intercooler and filters						○							4.16.8
Fan belt and air conditioner belt	Inspection		○										3.2.6
	Adjustment				⊙ (First time)	○							4.16.1
Cleaning or replacing radiator cap / reserve tank cap	Cleaning					○							4.16.6
	Replacement							○					
Checking engine mounting bracket for tightening condition								○					4.18.3
Checking intake system rubber hose						○							4.16.2
Cleaning and checking filter of electromagnetic fuel pump							○						4.17.9

## [4. INSPECTION AND MAINTENANCE]

Item/Interval	Irregular	Start-Up	Every 1 Month or 100H	Every 3 Months or 250H	Every 6 Months or 500H	Every 12 Months or 1,000H	2,000H	4,500H	5,000H	Grease (Replacement Part)	Procedure Description Section
		Inspection									
		8H	50H								
*Checking and adjusting valve clearance			⊙ (First time)			○					—
*Checking and adjusting compression pressure						○					—
*Checking intake and exhaust manifolds for tightening condition			⊙ (First time)			○					—
*Checking oil pan and other auxiliary devices for tightening condition			⊙ (First time)			○					—
*Checking each tightening part of turbo charger			⊙ (First time)			○					—
*Checking turbo charger rotor and impeller for rotation condition						○					—
*Checking play of turbo charger rotor						○					—
*Checking lubricating system of turbo charger for leakage		○				○					—
*Checking and cleaning starter brush and commutator						○					—
*Checking oil pan for mixing of water and fuel				○							—
*Checking fan mounting bolt for tightening condition				○							—
*Checking thermostat function						○					—
*Checking starter function						○					—
*Checking startability, exhaust color, and abnormal sound		○									—
*Checking heater plug and intake air heater (starting auxiliary device)					○						—
*Checking alternator function						○					—
*Checking pipe joints for tightening condition			⊙ (First time)			○					—
*Checking exhaust pipe and muffler for looseness of mounting part and damages			⊙ (First time)			○					—
*Checking and cleaning alternator brush (when brush is equipped)						○					—
*Cleaning EGR cooler								○			—
Checking each part for oil and fuel leakage		○									3.1
Checking each part for water leakage		○									3.1
Checking electrical system		○									—

### Notice

Contact your KOBELCO authorized dealer for inspection and adjustment of the items marked with \*.

**FUEL SYSTEM**

Item/Interval		Irregular	Start-Up Inspection 8H	50H	Every 1 Month or 100H	Every 3 Months or 250H	Every 6 Months or 500H	Every 12 Months or 1,000H	2,000H	4,500H	5,000H	Grease (Replacement Part)	Procedure Description Section
Fuel tank	Checking oil level		○										3.2.3
	Draining water and sediment			○									4.14.2
	Cleaning cap and strainer						○						4.17.6
Bleeding air from fuel piping		○											4.12.6

**SCR SYSTEM**

Item/Interval		Irregular	Start-Up Inspection 8H	50H	Every 1 Month or 100H	Every 3 Months or 250H	Every 6 Months or 500H	Every 12 Months or 1,000H	2,000H	4,500H	5,000H	Grease (Replacement Part)	Procedure Description Section
DEF/AdBlue tank	Checking fluid level		○										3.2.8
	Inspection					○							4.16.7
DEF/AdBlue piping	Inspection					○							4.16.7
DEF/AdBlue supply module	Inspection					○							4.16.7
*DEF/AdBlue supply module filter	Replacement								(3 years or 4500 H)				4.20.2
*DEF/AdBlue dosing module	Inspection					○							4.16.7
*SCR (insulation material)	Replacement									○		Gasket	4.20.2
*SCR system cooling water piping	Inspection					○							4.16.7
*Harness around SCR	Inspection					○							4.16.7

**HYDRAULIC SYSTEM**

Item/Interval		Irregular	Start-Up Inspection 8H	50H	Every 1 Month or 100H	Every 3 Months or 250H	Every 6 Months or 500H	Every 12 Months or 1,000H	2,000H	4,500H	5,000H	Grease (Replacement Part)	Procedure Description Section
Hydraulic oil tank	Hydraulic oil	Checking oil level	○										3.2.5
		Replacement						○ (Breaker)			○	Hydraulic oil	4.20.1
	Suction strainer	Cleaning							○			Strainer	4.19.4
	Replacing return filter			◎ (First time)		○ (Breaker)		○				Element	4.18.1
	Replacing air breather element							○				Element	4.18.2
Checking hydraulic components, pipes and hoses for oil leakage and damage			○										3.1
Cleaning pilot line filter									○				4.19.7

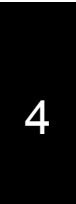

## [4. INSPECTION AND MAINTENANCE]

### UPPER FRAME

Item/Interval		Irregular	Start-Up Inspection	50H	Every 1 Month or	Every 3 Months or	Every 6 Months or	Every 12 Months or	2,000H	4,500H	5,000H	Grease (Replacement Part)	Procedure Description Section
			8H		100H	250H	500H	1,000H					
Swing reduction unit oil	Checking oil level			○ (120H)								Gear oil SAE #90 GL-4	4.15.1
	Replacement					◎ (First time)		○					
Greasing to swing bearing							○					EPG lithium added extreme-pressure grease	4.17.4
Checking grease of swing grease bath								○				EPG lithium added extreme-pressure grease	4.19.6
Swing brake function			○										—
Greasing to control lever push rod and universal joint part							○					EPG lithium added extreme-pressure grease	4.17.7
Installing swing bearing Checking bolt for looseness							○						4.17.5
Installing counterweight Checking bolt for looseness				◎ (First time)		○							4.8
Greasing swing reduction unit								○					4.19.5
Checking body structure			○										3.1

### LOWER FRAME

Item/Interval		Irregular	Start-Up Inspection	50H	Every 1 Month or	Every 3 Months or	Every 6 Months or	Every 12 Months or	2,000H	4,500H	5,000H	Grease (Replacement Part)	Procedure Description Section
			8H		100H	250H	500H	1,000H					
Travel reduction unit oil	Checking oil level			○ (120H)								Gear oil SAE #90 GL-4	4.15.2
	Replacement					◎ (First time)		○					
Adjusting tension of crawler				○									4.14.3
Checking upper roller and lower roller for oil leakage			○										3.1
Checking idler and travel reduction unit for oil leakage			○										3.1
Checking sprocket, idler, and roller for wear			○										3.1

**ATTACHMENT**

Item/Interval	Irregular	Start-Up Inspection	50H	Every 1 Month or 100H	Every 3 Months or 250H	Every 6 Months or 500H	Every 12 Months or 1,000H	2,000H	4,500H	5,000H	Grease (Replacement Part)	Procedure Description Section
		8H										
Greasing attachment (around bucket)		○ (Until 50 H)			○						EPG lithium added extreme-pressure grease	4.13.1
Greasing attachment		○ (Until 50 H)			○ (250 H is only for new machine)	○						
Replacing bucket	○											4.12.3
Replacing tooth and side cutter	○											4.12.4
Checking attachment structure		○										3.1
Greasing attachment (installation part of boom cylinder rod pin)	○											4.12.9

**ELECTRICITY**

Item/Interval	Irregular	Start-Up Inspection	50H	Every 1 Month or 100H	Every 3 Months or 250H	Every 6 Months or 500H	Every 12 Months or 1,000H	2,000H	4,500H	5,000H	Grease (Replacement Part)	Procedure Description Section
		8H										
Battery			○									4.14.1
			○									4.14.1
			○									4.14.1
							○					4.18.4
Electrical wiring		○										3.1
Check instruments, switches, and light warning devices for performance condition		○										3.2.11 3.2.12

**OTHER DEVICES**

Item/Interval	Irregular	Start-Up Inspection	50H	Every 1 Month or 100H	Every 3 Months or 250H	Every 6 Months or 500H	Every 12 Months or 1,000H	2,000H	4,500H	5,000H	Grease (Replacement Part)	Procedure Description Section
		8H										
Air conditioner						○						4.17.8
					○							4.16.8
	Filter					○						
			After about 10 times of cleaning									
Checking wiper blades	○											4.12.1
Checking washer fluid	○											4.12.2
Checking external appearance of machine for deformation and damages		○										3.1
Checking bolts and nuts for looseness and coming off		○										3.1
Seatbelt		○										2.11
									○ (3 years)			

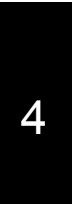

## 4.12 MAINTENANCE WHEN REQUIRED

Thoroughly read and understand "SAFETY PRECAUTIONS" of this manual before operating, inspecting or maintaining the machine.

### 4.12.1 CHECKING AND REPLACING WIPER BLADES

- Check the wiper blades and replace them if there is wear or damage.

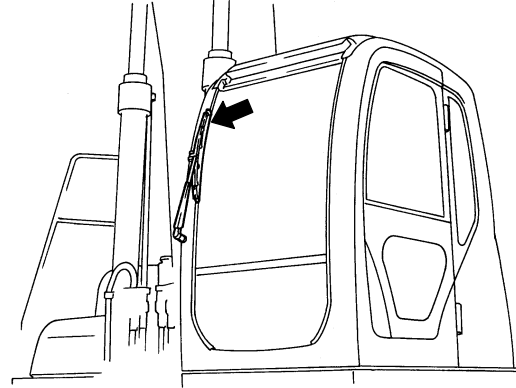

### 4.12.2 WASHER FLUID INSPECTION

**Notice**

If the washer is used when the washer tank is empty, the motor attached to the washer tank may be damaged.

1. Remove the floor mat.
2. Inspect the fluid level of washer tank (1).
3. When the washer fluid level becomes lower than (L), remove the cap and supply the washer fluid for automobiles.
4. Put the floor mat back to its original position.

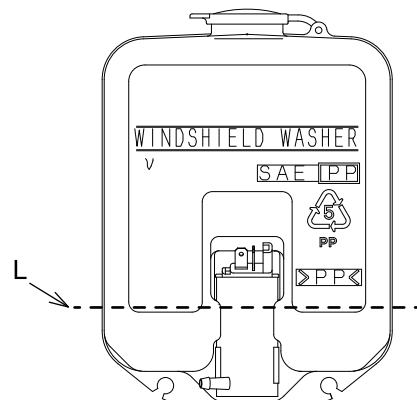
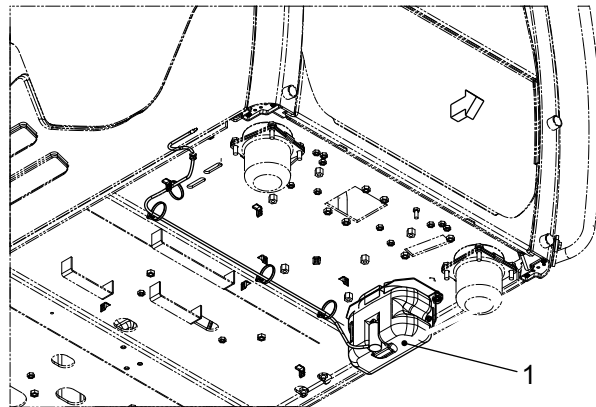



### 4.12.3 REPLACING BUCKET

#### **CAUTION**

- Park the machine on a level and firm place before operation. When working with other workers, surely send and receive signals to each other and use extreme caution to ensure the safety.
- Never operate the front attachment abruptly because it is dangerous.
- When aligning the pin with a pin hole, never insert your fingers into the hole.
- Place the removed bucket in the stable condition.

#### REMOVING BUCKET

1. Put the bucket bottom on a level ground and stabilize it at the position where the load is not applied on the pins of bucket and arm.
2. Move O-ring (1) from the specified position to bucket boss (9).

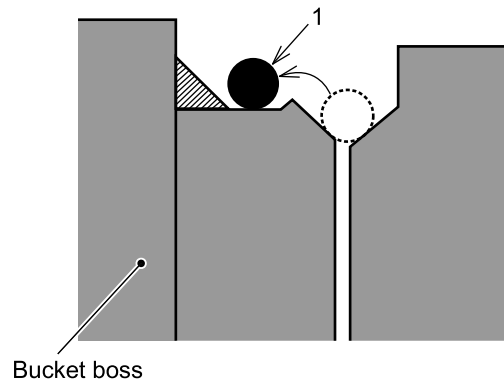

3. Remove retaining ring (2) and pin (3) by using a flat-head screwdriver.
4. Remove pins (4) and (5) and bucket (6). Use caution to prevent sand or mud from sticking to the removed pin. The both ends of pin holes of arm (7) and bucket link (8) have the dust seals. Be careful not to damage them.

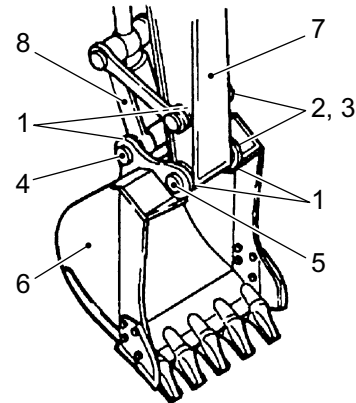

## [4. INSPECTION AND MAINTENANCE]

---

### INSTALLING BUCKET

---

#### Notice

If O-ring (1) is cracked or has lost elasticity, replace it with a new one.

---

1. Clean each pin and pin hole and grease it sufficiently to make it slippery.
2. Move the bucket cylinder to align the pin holes of bucket (6) and bucket link (8) with each other, and then insert pin (4).
3. Raise the boom to slightly raise the bucket from the ground.
4. Move arm (7) to align the pin holes of bucket (6) and arm (7) with each other, and then insert pin (5).
5. Insert pin (3) and install retaining ring (2).
6. Fit O-ring (1) in place.
7. Apply grease to the grease nipples for each pin until the grease comes out through the gap between the pin and the hole.

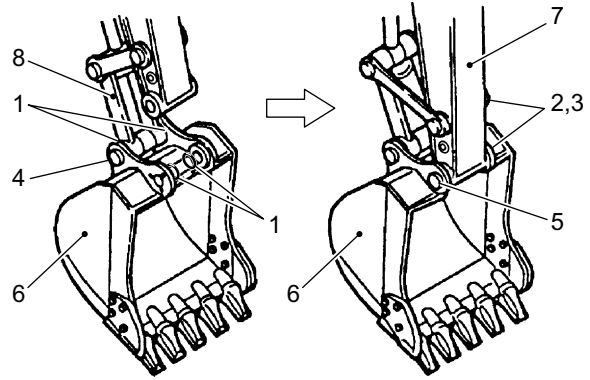

## 4.12.4 REPLACING TOOTH POINT AND SIDE CUTTER

### **CAUTION**

When replacing the tooth point or side cutter, apply a safety block to the bottom face of the bucket.

Check the bucket tooth points and side cutters for wear. The tooth point with holes or crackings should be replaced before adapter (1) begins to be worn. The side cutter with severe wear should be replaced soon after it is found. If the replacement is delayed, the body of the bucket will be damaged.

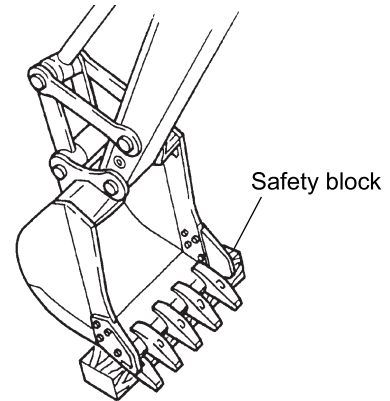

- (1) Adapter
- (2) Tooth point
- (3) Rubber lock pin
- (4) Locking pin
- (5) Side cutter
- (6) Bolt
- (7) Nut

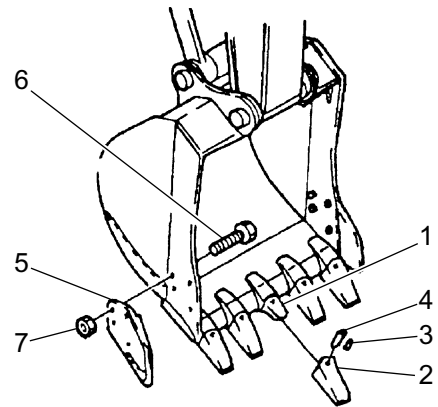

### REPLACING TOOTH POINTS

### **CAUTION**

When hammering, metal chips can fly. If it flies into your eye, it may result in severe injury. Wear protective gears such as protective glasses, hard hat and gloves.

## [4. INSPECTION AND MAINTENANCE]

1. Using a punching tool and hammer, hammer out locking pin (4) in a way that will not break rubber rock pin (3).
2. Inspect removed locking pin (4) and rubber lock pin (3).  
If the locking pin is too short or the rubber lock pin is in poor condition as shown in the figure, replace it with a new one.
3. Use a putty knife to clean the surface of adapter nose (1) and remove hardened soil.
4. Fit tooth point (2) onto adapter nose (1).
5. Push rubber lock pin (3) into the hole of adapter nose (1).
6. Hammer locking pin (4) until its surface is aligned with the point surface.

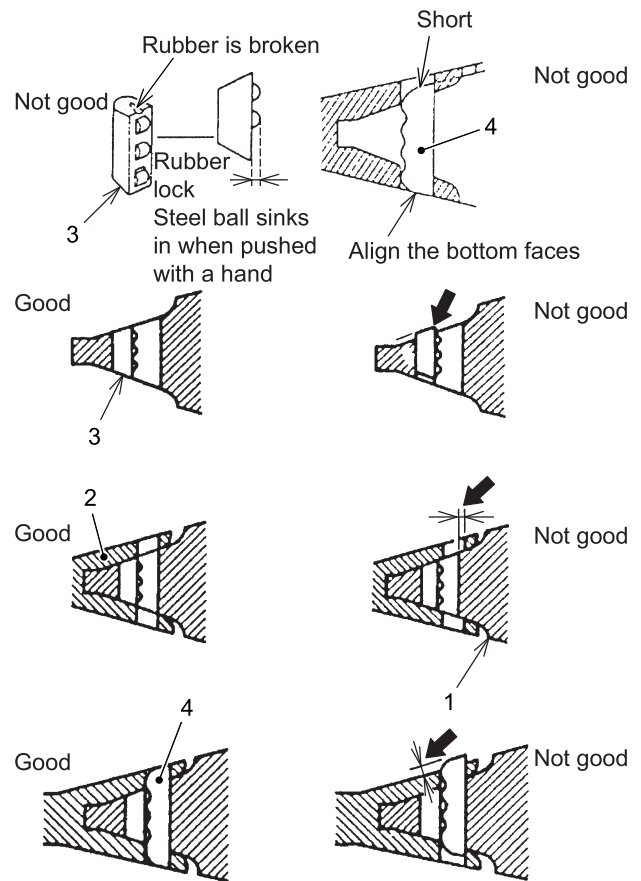

## REPLACING SIDE CUTTERS

**Notice**

If the replacement is delayed, the body of the bucket will be damaged.  
Early replacement is recommended.

1. After removing sand and soil sticking to around the mounting bolts, cut off the mounting bolts by gas cutting, and then remove the side cutters.
2. Clean the mounting surfaces and install new side cutters.  
When replacing the side cutters, be sure to replace the bolts and nuts with new ones.  
Tightening Torque:  $980 \pm 50\text{N}\cdot\text{m}$  ( $723 \pm 37\text{ lbf}\cdot\text{ft}$ )
3. After tightening the nuts, spot-weld them.

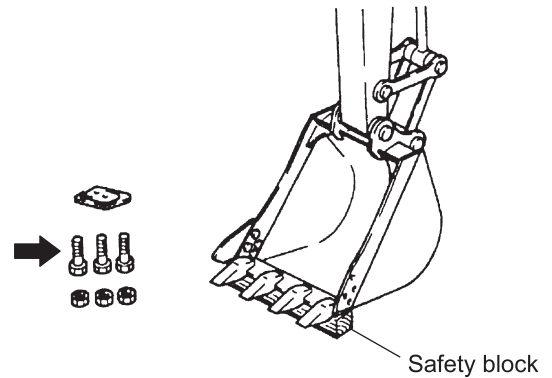
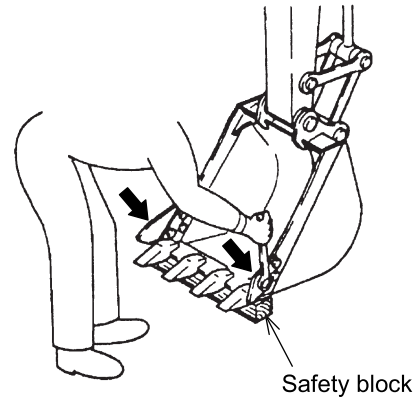

## 4.12.5 INSPECTION AND ADJUSTMENT OF BUCKET GAP ADJUSTMENT MECHANISM

### **CAUTION**

- When adjusting bucket gaps, pull up the pilot control shut-off lever to the "LOCKED" position and stop the engine.
- If the bucket gaps are not properly adjusted, galling is generated in the contact surface between the bucket and the arm causing abnormal noise and damage on the shaft the O-ring.

1. Place the bucket as shown in the figure in stable condition.

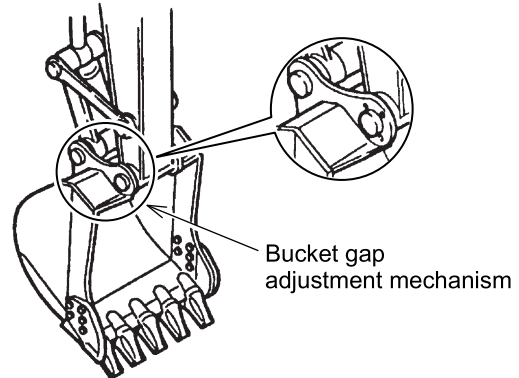

2. Move O-ring (1) from the specified position to the bucket boss.
3. Swing the upper structure right very slightly to press the tip of the arm to the right of the bucket lightly (the side without the gap adjustment system).
4. Move the pilot control shut-off lever to the "LOCKED" position, and then stop the engine.

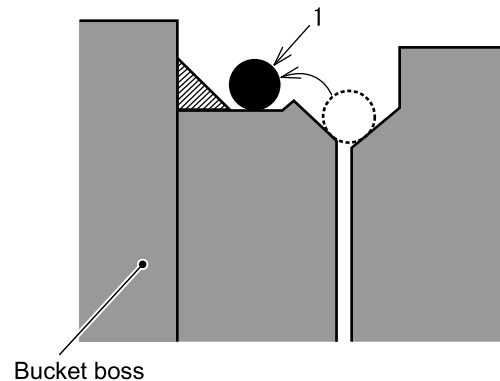

5. Measure gap (A) between the bucket and the arm boss.  
When the measurement value is 1.0 mm (0.04 inch) or more, adjust it.
6. Loosen each bolt, and remove appropriate number of shims to adjust the gap.  
There are 5 pieces of shims (3) {1 mm (0.04 inch)} in average in 3 bolts (2) on the gap adjustment part.
7. Tighten bolts (2) with the specified tightening torque evenly.  
Tightening Torque:  $181 \pm 20 \text{ N} \cdot \text{m}$  ( $133 \pm 15 \text{ lbf} \cdot \text{ft}$ )
8. Fit O-ring (1) in place.

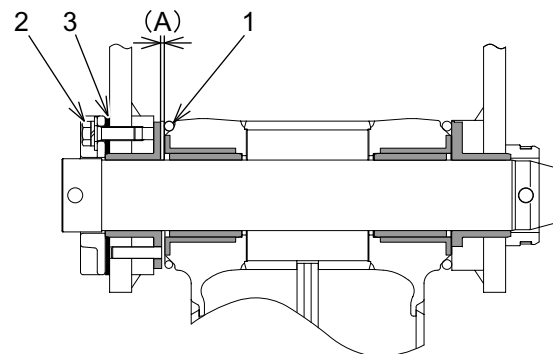

### 4.12.6 BLEEDING AIR FROM FUEL PIPING

After replacing the element of fuel filter or in case of running out of fuel, air enters the fuel piping and the engine cannot be started.

Bleed the air according to the following procedure:



#### BLEEDING AIR FROM FUEL PIPING

- Wipe off spilled fuel to prevent a fire.
- Make sure that there is no fuel leakage after performing work.

1. Turn the starter switch to "ON" to activate the fuel electromagnetic pump.
2. Place a container for fuel under fuel filter (1).
3. Clean the area around air bleeder plug (2) and loosen the air bleeder plug.
4. Push priming pump (3) repeatedly.
5. When fuel without bubbles comes out of the air bleeder plug, tighten the air bleeder plug.
6. After air bleeding is completed, wipe off any leaked fuel.
7. After replacing the fuel filter, before starting the engine, wait for 10 minutes with the starter switch kept in "ON" position to remove contaminant foreign materials.
8. Run the engine and check the parts for fuel leakage.

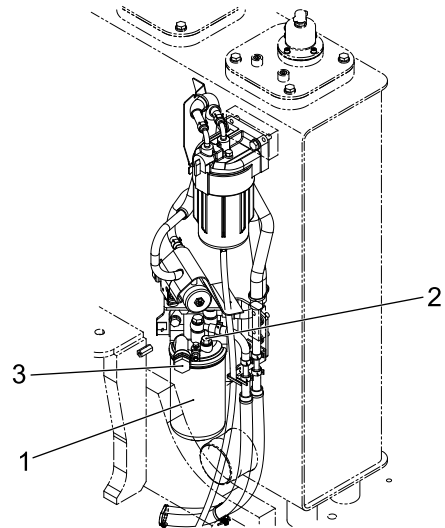

### 4.12.7 CLEANING CAB SKYLIGHT

---

**CAUTION**

- When cleaning the cab skylight, pull up the control lock lever to the "LOCKED position" and stop the engine.

Before starting cleaning, place the work platform at the left side of the machine.

1. Release lock (1) of the cab guard.

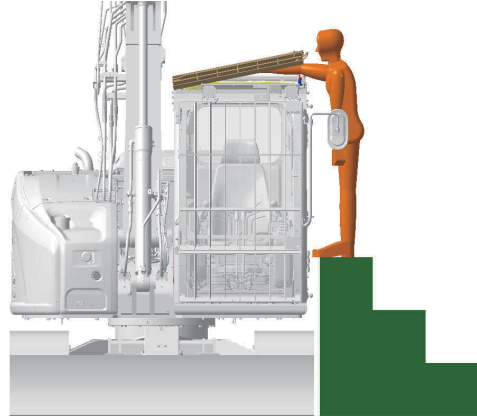

2. Lift up the cab guard and fix it with support stay (2).

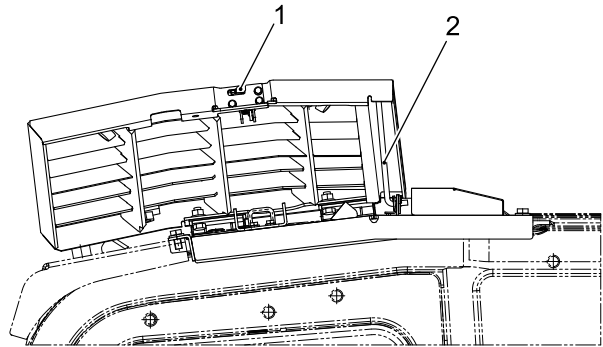

**CAUTION**

Securely fix the cab guard with the support stay in order to avoid your hand from being caught, resulting in injuries.

---

3. Clean the cab skylight.
4. After cleaning the cab skylight, release the support stay, close the cab guard, and then lock it.



## 4.12.8 RELEASING INTERNAL PRESSURE IN HYDRAULIC SYSTEM

Before replacing the front attachment or the hydraulic piping, release the internal pressure of the hydraulic system. Release the internal pressure of the hydraulic system following the next steps.

**WARNING**

### RELEASING INTERNAL PRESSURE IN HYDRAULIC SYSTEM

Immediately after operation, there is a hazard of getting burn by heated parts. Wait until the temperatures decrease before starting works.

1. Move the machine to a level and firm place.
2. Retract the arm cylinder and bucket cylinder, and place the bucket on the ground.
3. Start the engine.

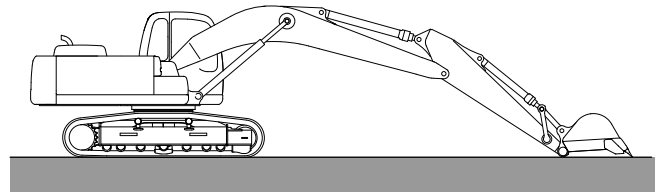

4. Release the internal pressure referring to "PRESSURE RELEASE" in Paragraph "SETTING MENU SCREEN" in Chapter 2.  
When internal pressure releasing is started, "DRAINING HYD. PRESS." is displayed on the monitor and the engine speed is reduced to a low speed.
5. The buzzer sounds intermittently.  
(To stop the buzzer, push the buzzer stop switch).
6. In this condition, move the control levers of the attachment/equipment to release the pressure.  
Be cautious that the attachment/equipment may move due to its own weight.
7. Set the starter key to "OFF" to stop the engine and to finish releasing the internal pressure.

**DRAINING HYD. PRESS.****CAUTION**

After turning the key OFF and finishing the internal pressure releasing, wait 5 minutes or more before turning the key ON again.

If the key is turned ON again soon after the key OFF, it may cause the internal pressure releasing to finish improperly, resulting in continued releasing operation.

- When releasing the internal pressure is failed, "FAIL DRAIN HYD. PRESS" is displayed on the monitor, and the buzzer sounds continuously. In that case, turn the starter key "OFF", wait 5 minutes or more, and then perform procedures 4. to 7. again.

**FAIL DRAIN HYD. PRESS.**

### 4.12.9 GREASING ATTACHMENT/EQUIPMENT

When greasing the boom side bosses located at the boom cylinder rod installation part, grease two grease nipples shown in the figure.

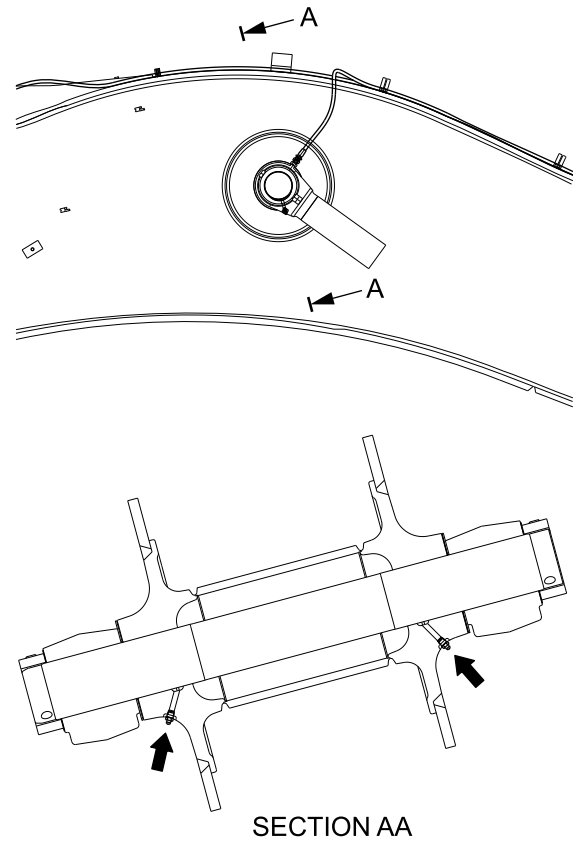

---

**Notice**

Some machine specifications do not have the grease nipples for greasing.

---